

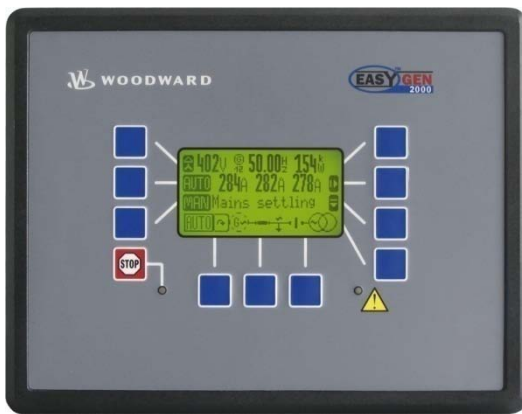

easYgen-2000 Series Genset Control



Configuration
Software Version 1.xxxx

**WARNING**

Read this entire manual and all other publications pertaining to the work to be performed before installing, operating, or servicing this equipment. Practice all plant and safety instructions and precautions. Failure to follow instructions can cause personal injury and/or property damage.

The engine, turbine, or other type of prime mover should be equipped with an overspeed (overtemperature, or overpressure, where applicable) shutdown device(s), that operates totally independently of the prime mover control device(s) to protect against runaway or damage to the engine, turbine, or other type of prime mover with possible personal injury or loss of life should the mechanical-hydraulic governor(s) or electric control(s), the actuator(s), fuel control(s), the driving mechanism(s), the linkage(s), or the controlled device(s) fail.

Any unauthorized modifications to or use of this equipment outside its specified mechanical, electrical, or other operating limits may cause personal injury and/or property damage, including damage to the equipment. Any such unauthorized modifications: (i) constitute "misuse" and/or "negligence" within the meaning of the product warranty thereby excluding warranty coverage for any resulting damage, and (ii) invalidate product certifications or listings.

**CAUTION**

To prevent damage to a control system that uses an alternator or battery-charging device, make sure the charging device is turned off before disconnecting the battery from the system.

Electronic controls contain static-sensitive parts. Observe the following precautions to prevent damage to these parts.

- Discharge body static before handling the control (with power to the control turned off, contact a grounded surface and maintain contact while handling the control).
- Avoid all plastic, vinyl, and Styrofoam (except antistatic versions) around printed circuit boards.
- Do not touch the components or conductors on a printed circuit board with your hands or with conductive devices.

**OUT-OF-DATE PUBLICATION**

This publication may have been revised or updated since this copy was produced. To verify that you have the latest revision, be sure to check the Woodward website:

<http://www.woodward.com/pubs/current.pdf>

The revision level is shown at the bottom of the front cover after the publication number. The latest version of most publications is available at:

<http://www.woodward.com/publications>

If your publication is not there, please contact your customer service representative to get the latest copy.

Important definitions**WARNING**

Indicates a potentially hazardous situation that, if not avoided, could result in death or serious injury.

**CAUTION**

Indicates a potentially hazardous situation that, if not avoided, could result in damage to equipment.

**NOTE**

Provides other helpful information that does not fall under the warning or caution categories.

Woodward reserves the right to update any portion of this publication at any time. Information provided by Woodward is believed to be correct and reliable. However, Woodward assumes no responsibility unless otherwise expressly undertaken.

© Woodward
All Rights Reserved.

Revision History

Rev.	Date	Editor	Changes
NEW	09-06-09	TE	Release
A	10-06-07	TE	Minor corrections

Content

CHAPTER 1. GENERAL INFORMATION	12
Document Overview	12
Abbreviations	13
CHAPTER 2. CONFIGURATION	14
Configuration Via The Front Panel.....	14
Configuration Using The PC	15
Install ToolKit Configuration and Visualization Software.....	15
Configure ToolKit.....	16
ToolKit Files.....	17
Language-Dependent SID Files	18
SID Files for Using ToolKit on the CAN Bus With Other CANopen Devices.....	18
Loading WSET Files of Previous Revisions	18
Connect ToolKit and the easYgen Unit	19
View easYgen Data with ToolKit	20
Configure the easYgen with ToolKit.....	21
The Settings File Function of ToolKit	21
Function of the Inputs and Outputs.....	22
CHAPTER 3. PARAMETERS.....	26
Configure Language / Clock.....	27
Configure Display.....	30
Lamp Test	30
Enter Password.....	31
System Management	33
System Management: Password System	35
Configuration.....	36
Configure Measurement.....	37
Configure Measurement: Configure Transformer	44
Generator	44
Busbar.....	46
Mains PT	47
Mains Current Transformer	47
Ground Current Transformer.....	48

Configure Monitoring	49
Configure Monitoring: Generator	49
Configure Monitoring: Generator, Operating Voltage / Frequency	50
Configure Monitoring: Generator, Overfrequency (Levels 1 & 2) ANSI# 81O	51
Configure Monitoring: Generator, Underfrequency (Levels 1 & 2) ANSI# 81U	53
Configure Monitoring: Generator, Overvoltage (Levels 1 & 2) ANSI# 59	55
Configure Monitoring: Generator, Undervoltage (Levels 1 & 2) ANSI# 27	57
Configure Monitoring: Generator, Time-Overcurrent Monit. (Levels 1, 2 & 3) ANSI# 50/51	59
Configure Monitoring: Generator, Reverse/Reduced Power (Levels 1 & 2) ANSI# 32R/F	61
Configure Monitoring: Generator, Overload IOP (Levels 1 & 2) ANSI# 32	63
Configure Monitoring: Generator, Overload MOP (Levels 1 & 2) ANSI# 32	65
Configure Monitoring: Generator, Unbalanced Load (Levels 1 & 2) ANSI# 46	67
Configure Monitoring: Generator, Voltage Asymmetry	70
Configure Monitoring: Generator, Ground Fault (Levels 1 & 2)	72
Configure Monitoring: Generator, Phase Rotation	75
Configure Monitoring: Generator, Inverse Time-Overcurrent Monitoring ANSI# IEC 255	77
Configure Monitoring: Generator, Lagging Power Factor Monitoring (Levels 1 & 2)	81
Configure Monitoring: Generator, Leading Power Factor Monitoring (Levels 1 & 2)	83
Configure Monitoring: Mains	85
Configure Monitoring: Mains, Operating Voltage / Frequency	85
Configure Monitoring: Mains, Decoupling	87
Configure Monitoring: Mains, Overfrequency (Levels 1 & 2) ANSI# 81O	89
Configure Monitoring: Mains, Underfrequency (Levels 1 & 2) ANSI# 81U	91
Configure Monitoring: Mains, Overvoltage (Levels 1 & 2) ANSI# 59	93
Configure Monitoring: Mains, Undervoltage (Levels 1 & 2) ANSI# 27	95
Configure Monitoring: Mains, Phase Shift	97
Configure Monitoring: Mains, Voltage Phase Rotation - {2oc}	100
Configure Monitoring: Engine	102
Configure Monitoring: Engine, Overspeed (Levels 1 & 2) ANSI# 12	102
Configure Monitoring: Engine, Underspeed (Levels 1 & 2)	104
Configure Monitoring: Engine/Generator, Speed Detection (Speed/Frequency Mismatch)	106
Configure Monitoring: Engine, Generator Active Power Mismatch	108
Configure Monitoring: Engine, Mains Active Power Mismatch	109
Configure Monitoring: Engine, Generator Unloading Mismatch	110
Configure Monitoring: Engine, Start Failure	111
Configure Monitoring: Engine, Shutdown Malfunction	112
Configure Monitoring: Engine, Unintended Stop	113
Configure Monitoring: Engine, Operating Range Failure	114
Configure Monitoring: Engine, Charge Alternator (D+)	115
Configure Monitoring: Breaker Monitoring	116
Configure GCB	116
Configure Synchronization GCB	117
Configure MCB {2oc}	118
Configure Synchronization MCB	120
Configure Monitoring: Breakers, Generator / Busbar / Mains Phase Rotation - {2oc}	121
Configure Monitoring: Flexible Limits	122
Configure Monitoring: Miscellaneous	126
Configure Monitoring: Miscellaneous, Alarm Acknowledgement	126
Configure Monitoring: Miscellaneous, Configure CAN bus overload	127
Configure Monitoring: Miscellaneous, Configure CAN Interface 1	128
Configure Monitoring: Miscellaneous, Configure CAN Interface 2	129
Configure Monitoring: Miscellaneous, Configure CAN Interface 2, J1939 Interface	130
Configure Monitoring: Miscellaneous, Battery, Overvoltage (Levels 1 & 2)	133
Configure Monitoring: Miscellaneous, Battery, Undervoltage (Levels 1 & 2)	135
Configure Monitoring: Miscellaneous, Multi-Unit Parameter Alignment	137
Configure Monitoring: Miscellaneous, Multi-Unit Missing Members	139

Configure Application	140
Configure Application: Configure Breakers	140
Operation Of The Circuit Breakers	142
Configure Application: Configure Breakers, Dead Bus Detection Limit	150
Configure Application: Configure Breakers, GCB	151
Configure Application: Configure Breakers, MCB	155
Configure Application: Configure Breakers, Synchronization	157
Configure Application: Configure Inputs and Outputs	158
Configure Analog Inputs (<i>FlexIn</i>)	158
Configure Discrete Inputs	168
Configure External Discrete Inputs	171
Discrete Outputs (<i>LogicsManager</i>)	172
External Discrete Outputs (<i>LogicsManager</i>)	173
Configure Analog Outputs	173
Configure Application: Configure Engine	178
Configure Application: Configure Engine, Engine Type	178
Configure Application: Configure Engine, Start/Stop	184
Configure Application: Configure Engine, MPU	189
Configure Application: Configure Engine, Idle Mode	190
Configure Application: Configure Emergency Run	191
Configure Application: Configure Automatic Run	193
Configure Application: Automatic, Start In AUTOMATIC Operating Mode (<i>LogicsManager</i>)	193
Configure Application: Automatic, Stop In AUTOMATIC Operating Mode (<i>LogicsManager</i>)	194
Configure Application: Automatic, Load-Dependent Start/Stop (LDSS)	195
Configure Application: Automatic, Start w/o Load (<i>LogicsManager</i>)	211
Configure Application: Automatic, Operation Modes	211
Configure Application: Automatic, Critical Mode (Sprinkler Operation, <i>LogicsManager</i>)	212
Configure Application: Configure Controller	217
Overview	217
PID Tuning Example	218
Configure Application: Controller, Frequency Control	219
Configure Application: Controller, Load Control	225
Configure Application: Controller, Voltage Control	231
Configure Application: Controller, Power Factor Control	236
Configure Application: Controller, Load Share Control	240
Configure Application: Controller, Discrete Raise/Low/Function	247
Configure Interfaces	248
Configure Interfaces: Configure CAN Interfaces (<i>FlexCAN</i>)	248
Configure CAN Interface 1	248
Configure CAN Interface 2	257
Load Share Parameters	262
Configure Interfaces: Configure RS-232 Interfaces	263
Configure Serial Interface 1	263
Configure Interfaces: Configure RS-485 Interfaces	264
Configure Serial Interface 2	264
Configure <i>LogicsManager</i>	265
Configure <i>LogicsManager</i> : Configure Internal Flags	265
Configure <i>LogicsManager</i> : Set Timer	266
<i>LogicsManager</i> : Daily Time Set Point	266
<i>LogicsManager</i> : Active Time Set Point	266
<i>LogicsManager</i> : Weekly Time Set Point	267
Configure Counters	268
Configure Counters: Maintenance Call	268
Configure Counters: Operation Hours, kWh, and kvarh	269
Configure Counters: Start Counter	270
Configure Counters: Operation Hours	270

APPENDIX A. MISCELLANEOUS	271
Alarm Classes.....	271
Conversion Factors.....	272
Temperature.....	272
Pressure.....	272
APPENDIX B. LOGICSMANAGER	273
Structure and Description of the <i>LogicsManager</i>	273
Configuration of the Command Chain.....	274
Logical Symbols.....	274
Logical Outputs.....	275
Logical Outputs: Internal Flags	275
Logical Outputs: Internal Functions	276
Priority Hierarchy of the Logical Outputs	277
Logical Outputs: Relay Outputs	278
Logical Command Variables.....	279
Logical Command Variables: Group 00: Flags Condition 1.....	280
Logical Command Variables: Group 01: Alarm System	282
Logical Command Variables: Group 02: Systems Condition.....	283
Logical Command Variables: Group 03: Engine Control.....	284
Logical Command Variables: Group 04: Applications Condition	285
Logical Command Variables: Group 05: Engine Related Alarms.....	286
Logical Command Variables: Group 06: Generator Related Alarms.....	287
Logical Command Variables: Group 07: Mains Related Alarms	288
Logical Command Variables: Group 08: System Related Alarms	288
Logical Command Variables: Group 09: Discrete Inputs.....	289
Logical Command Variables: Group 10: Analog Inputs.....	289
Logical Command Variables: Group 11: Clock and Timer	289
Logical Command Variables: Group 12: External Discrete Inputs 1	290
Logical Command Variables: Group 13: Discrete Outputs.....	290
Logical Command Variables: Group 14: External Discrete Outputs 1.....	291
Logical Command Variables: Group 15: Flexible Limits	291
Logical Command Variables: Group 18: Transistor Outputs	291
Factory Setting.....	292
Factory Setting: Functions	292
Factory Setting: Relay Outputs	302
Discrete Inputs	306

APPENDIX C. ANALOG MANAGER.....	307
Data Sources	307
Group 00: Internal Values	307
Group 01: Generator Values	308
Group 02: Mains Values	308
Group 05: Controller Set Points	309
Group 06: DC Analog Input Values	309
Group 07: Engine Values	310
Reference Values.....	312
Generator Rated Voltage	312
Mains Rated Voltage	312
Rated Frequency	313
Generator Rated Active Power.....	313
Generator Rated Reactive Power	314
Mains Rated Active Power	314
Mains Rated Reactive Power.....	315
Generator Rated Apparent Power.....	315
Mains Rated Apparent Power	316
Generator / Mains Power Factor	317
Generator Rated Current.....	318
Mains Rated Current	318
Rated Speed.....	318
Battery Voltage	319
Busbar 1 Rated Voltage	319
Display Value Format	319
APPENDIX D. EVENT HISTORY.....	320
Resetting the Event History	320
Resetting the Event History Using the Front Panel	320
Event List.....	320
Alarm List	320
APPENDIX E. TRIGGERING CHARACTERISTICS.....	323
Time-Dependent Overshoot Monitoring	323
Two-Level Overshoot Monitoring	324
Two-Level Undershoot Monitoring	325
Two-Level Reversed/Reduced Load Monitoring.....	326
Two-Level Unbalanced Load Monitoring	327
One-Level Asymmetry Monitoring.....	328
APPENDIX F. CHARACTERISTICS OF THE VDO INPUTS.....	329
VDO Input "Pressure" (0 to 5 bar / 0 to 72 psi) - Index "III"	329
VDO Input "Pressure" (0 to 10 bar / 0 to 145 psi) - Index "IV"	330
VDO Input "Temperature" (40 to 120 °C / 104 to 248 °F) - Index "92-027-004".....	331
VDO Input "Temperature" (50 to 150 °C / 122 to 302 °F) - Index "92-027-006".....	332
Pt100 RTD.....	333

APPENDIX G. LDSS FORMULAS	334
Abbreviations	334
LDSS Mode Reserve Power.....	334
Isolated Operation.....	334
Changing the Engine Combination to Increase Rated Power	334
Changing the Engine Combination to Reduce Rated Power	334
Mains Parallel Operation (Import/Export Control).....	334
Starting the First Engine Combination (no engine supplies the busbar)	334
Changing the Engine Combination to Increase Rated Power	334
Changing the Engine Combination to Reduce Rated Power	334
Stopping the Last Engine Combination (load close to minimum load)	334
LDSS Mode Generator Load	335
Isolated Operation.....	335
Changing the Engine Combination to Increase Rated Power	335
Changing the Engine Combination to Reduce Rated Power (except dynamic set point is not matched).....	335
Mains Parallel Operation (Import/Export Control).....	335
Starting the First Engine Combination (no engine supplies the busbar)	335
Changing the Engine Combination to Increase Rated Power	335
Changing the Engine Combination to Reduce Rated Power (except dynamic set point is not matched).....	335
Stopping the Last Engine Combination (load close to minimum load)	335
LDSS Dynamic	335
APPENDIX H. SERVICE OPTIONS	336
Product Service Options	336
Returning Equipment For Repair	336
Packing A Control	337
Return Authorization Number RAN.....	337
Replacement Parts	337
How To Contact Woodward.....	338
Engineering Services.....	339
Technical Assistance	340

Figures and Tables

Figures

Figure 2-1: ToolKit - Options window.....	16
Figure 2-2: ToolKit - visualization screen	20
Figure 2-3: ToolKit - analog value trending screen	20
Figure 2-4: ToolKit - configuration screen	21
Figure 3-1: Code level display	32
Figure 3-2: Configure measurement - generator type selection	38
Figure 3-3: AC power triangle	41
Figure 3-4: Monitoring - calculated generator ground fault.....	72
Figure 3-5: Monitoring - calculated generator ground current - vector diagram.....	73
Figure 3-6: Monitoring - generator inverse time-overcurrent - "Normal inverse" characteristic	77
Figure 3-7: Monitoring - generator inverse time-overcurrent - "Highly inverse" characteristic.....	78
Figure 3-8: Monitoring - generator inverse time-overcurrent - "Extremely inverse" characteristic	78
Figure 3-9: Monitoring - generator lagging power factor	81
Figure 3-10: Monitoring - generator leading power factor.....	83
Figure 3-11: Monitoring - phase shift	97
Figure 3-12: Monitoring - plausibility check n/f.....	106
Figure 3-13: Monitoring - flexible limits - data source selection	123
Figure 3-14: Monitoring - miscellaneous – parameter alignment	137
Figure 3-15: Normally Open / Normally Closed contacts.....	151
Figure 3-16: Analog input scaling - table (example).....	158
Figure 3-17: Discrete inputs - alarm/control inputs - operation logic	168
Figure 3-18: Monitoring - analog outputs - data source selection.....	175
Figure 3-19: Configure application - engine - preglow criterion selection.....	179
Figure 3-20: Start /stop sequence - diesel engine	180
Figure 3-21: Start /stop sequence - gas engine - successful	182
Figure 3-22: Start /stop sequence - gas engine - unsuccessful	183
Figure 3-23: Engine - firing speed and engine delayed monitoring	185
Figure 3-24: Engine - Auxiliary services timing	188
Figure 3-25: Automatic run - engine start conditions.....	194
Figure 3-26: Automatic - Critical operation at busbar.....	212
Figure 3-27: Automatic - Critical operation at generator	214
Figure 3-28: Controllers - Behavior of the derivative parameter	218
Figure 3-29: CAN bus load/var sharing, diagram	242
Figure 3-30: Load sharing - grouping	245
Figure 3-31: Interfaces - Principle of PDO mapping	252
Figure 3-32: <i>LogicsManager</i> - function overview	273
Figure 3-33: <i>LogicsManager</i> - display in ToolKit.....	274
Figure 3-34: <i>LogicsManager</i> - display on LCD screen	274
Figure 3-35: Reference values - power factor scaling.....	317
Figure 3-36: Triggering characteristics - three-level time-dependent overshoot monitoring	323
Figure 3-37: Triggering characteristics - two-level overshoot monitoring.....	324
Figure 3-38: Triggering characteristics - two-level undershoot monitoring.....	325
Figure 3-39: Triggering characteristics - two-level reversed/reduced load monitoring.....	326
Figure 3-40: Triggering characteristics - two-level unbalanced load monitoring.....	327
Figure 3-41: Triggering characteristics - one-level asymmetry monitoring.....	328
Figure 3-42: Analog inputs - characteristics diagram VDO 0 to 5 bar, Index "III"	329
Figure 3-43: Analog inputs - characteristics diagram VDO 0 to 10 bar, Index "IV"	330
Figure 3-44: Analog inputs - characteristics diagram VDO 40 to 120 °C, Index "92-027-004"	331
Figure 3-45: Analog inputs - characteristics diagram VDO 50 to 150 °C, Index "92-027-006"	332
Figure 3-46: Analog inputs - characteristics diagram Pt100	333

Tables

Table 1-1: Manual - overview.....	12
Table 3-1: Configuration - standard values - configure language/clock.....	27
Table 3-2: Daylight saving time - configuration example.....	30
Table 3-3: Daylight saving time - exemplary dates.....	30
Table 3-4: Configuration - standard values - enter password.....	31
Table 3-5: Configuration - standard values - system management.....	33
Table 3-6: Configuration - standard values - system management: password system.....	35
Table 3-7: Measurement - standard values - configure measurement.....	37
Table 3-8: Measurement - standard values - configure transformer.....	44
Table 3-9: Monitoring - standard values - configure generator monitoring.....	49
Table 3-10: Monitoring - standard values - configure generator operating voltage / frequency.....	50
Table 3-11: Monitoring - standard values - generator overfrequency.....	51
Table 3-12: Monitoring - standard values - generator underfrequency.....	53
Table 3-13: Monitoring - standard values - generator overvoltage.....	55
Table 3-14: Monitoring - standard values - generator undervoltage.....	57
Table 3-15: Monitoring - standard values - generator time-overcurrent.....	59
Table 3-16: Monitoring - standard values - generator reverse / reduced power.....	61
Table 3-17: Monitoring - standard values - generator overload IOP.....	63
Table 3-18: Monitoring - standard values - generator overload MOP.....	65
Table 3-19: Monitoring - standard values - generator unbalanced load.....	67
Table 3-20: Monitoring - standard values - generator voltage asymmetry.....	70
Table 3-21: Monitoring - standard values - generator ground fault.....	73
Table 3-22: Monitoring - standard values - generator voltage phase rotation.....	75
Table 3-23: Monitoring - standard values - generator inverse time-overcurrent.....	79
Table 3-24: Monitoring - standard values - generator lagging power factor.....	81
Table 3-25: Monitoring - standard values - generator leading power factor.....	83
Table 3-26: Monitoring - standard values - configure mains monitoring.....	85
Table 3-27: Monitoring - standard values - configure mains operating voltage / frequency.....	85
Table 3-28: Monitoring - standard values - mains decoupling.....	87
Table 3-29: Monitoring - standard values - mains overfrequency.....	89
Table 3-30: Monitoring - standard values - mains underfrequency.....	91
Table 3-31: Monitoring - standard values - mains overvoltage.....	93
Table 3-32: Monitoring - standard values - mains undervoltage.....	95
Table 3-33: Monitoring - standard values - mains phase shift.....	97
Table 3-34: Monitoring - standard values - mains voltage phase rotation.....	100
Table 3-35: Monitoring - standard values - engine overspeed.....	102
Table 3-36: Monitoring - standard values - engine underspeed.....	104
Table 3-37: Monitoring - standard values - plausibility control n/f.....	107
Table 3-38: Monitoring - standard values - generator active power mismatch.....	108
Table 3-39: Monitoring - standard values - mains active power mismatch.....	109
Table 3-40: Monitoring - standard values - generator unloading mismatch.....	110
Table 3-41: Monitoring - standard values - engine start failure.....	111
Table 3-42: Monitoring - standard values - engine shutdown malfunction.....	112
Table 3-43: Monitoring - standard values - engine unintended stop.....	113
Table 3-44: Monitoring - standard values - engine dead bus operation.....	114
Table 3-45: Monitoring - standard values - engine charge alternator failure.....	115
Table 3-46: Monitoring - standard values - breaker monitoring - GCB.....	116
Table 3-47: Monitoring - standard values - breaker monitoring - GCB synchronization.....	117
Table 3-48: Monitoring - standard values - breaker monitoring - MCB.....	118
Table 3-49: Monitoring - standard values - breaker monitoring - MCB synchronization.....	120
Table 3-50: Monitoring - standard values - mains voltage phase rotation.....	121
Table 3-51: Monitoring - standard values - flexible limits.....	122
Table 3-52: Monitoring - flexible limit examples.....	122
Table 3-53: Monitoring - flexible limits - analog value examples.....	124
Table 3-54: Monitoring - flexible limits - parameter IDs.....	125
Table 3-55: Monitoring - standard values - CAN bus overload.....	127
Table 3-56: Monitoring - standard values - CANopen interface 1.....	128
Table 3-57: Monitoring - standard values - CANopen interface 2.....	129
Table 3-58: Monitoring - standard values - J1939 interface.....	130
Table 3-59: Monitoring - standard values - J1939 interface red stop lamp.....	131
Table 3-60: Monitoring - standard values - J1939 interface amber warning lamp.....	132
Table 3-61: Monitoring - standard values - battery overvoltage.....	133
Table 3-62: Monitoring - standard values - battery undervoltage.....	135
Table 3-63: Monitoring - standard values - multi-unit parameter alignment monitoring.....	137
Table 3-64: Monitoring - standard values - multi-unit missing members monitoring.....	139

Table 3-65: Application - standard values - configure breakers.....	140
Table 3-66: Application - standard values - configure GCB	151
Table 3-67: Application - standard values - configure MCB	155
Table 3-68: Application - standard values - configure synchronization.....	157
Table 3-69: Application - standard values - configure analog inputs.....	158
Table 3-70: Application - standard values - configure analog input table A / B	159
Table 3-71: Analog inputs - table characteristics - parameter IDs	160
Table 3-72: Application - standard values - configure analog inputs 1 to 3.....	161
Table 3-73: Discrete inputs - terminal assignment.....	168
Table 3-74: Application - standard values - configure discrete inputs	168
Table 3-75: Discrete inputs - parameter IDs	170
Table 3-76: Application - standard values - configure discrete inputs	171
Table 3-77: External discrete inputs - parameter IDs.....	171
Table 3-78: Relay outputs - assignment.....	172
Table 3-79: Discrete outputs - parameter IDs	172
Table 3-80: External discrete outputs - parameter IDs.....	173
Table 3-81: Analog outputs 1/2 - parameter table.....	173
Table 3-82: Application - standard values - configure analog outputs 1/2.....	173
Table 3-83: Analog outputs 3/4 - parameter table.....	174
Table 3-84: Application - standard values - configure analog outputs 3/4.....	174
Table 3-85: Analog outputs - signal type selection	176
Table 3-86: Application - standard values - configure engine type.....	178
Table 3-87: Application - standard values - configure start/stop.....	184
Table 3-88: Application - standard values - configure MPU.....	189
Table 3-89: MPU input - typical configurations	189
Table 3-90: Application - standard values - configure idle mode	190
Table 3-91: Application - standard values - configure emergency run.....	192
Table 3-92: Application - standard values - configure automatic run	193
Table 3-93: Load-dependent start/stop - parameters for reserve power operation	195
Table 3-94: Load-dependent start/stop - parameters for generator load operation.....	196
Table 3-95: Application - standard values - configure load dependent start/stop.....	198
Table 3-96: Application - standard values - configure load dependent start/stop IOP	203
Table 3-97: Load-dependent start/stop - dynamic influence on stopping a genset.....	206
Table 3-98: Application - standard values - configure load dependent start/stop MOP	207
Table 3-99: Application - standard values - configure critical mode	216
Table 3-100: Application - standard values - configure frequency control.....	219
Table 3-101: Application - standard values - configure load control	225
Table 3-102: Application - standard values - configure voltage control	231
Table 3-103: Application - standard values - configure power factor control.....	236
Table 3-104: Application - standard values - configure load share	243
Table 3-105: Application - standard values - configure discrete raise/lower function	247
Table 3-106: Application - standard values - configure CAN interface 1	248
Table 3-107: Application - standard values - configure CAN interface 1: additional Server SDOs	251
Table 3-108: Application - standard values - configure CAN interface 1: receive PDOs	252
Table 3-109: Application - standard values - configure CAN interface 1: transmit PDOs.....	254
Table 3-110: Application - standard values - configure CAN interface 2	257
Table 3-111: Application - standard values - configure CAN interface 2: CANopen.....	257
Table 3-112: Application - standard values - configure CAN interface 2: J1939.....	259
Table 3-113: Application - standard values - configure CAN interface: load share.....	262
Table 3-114: Application - standard values - configure RS-232 interface: serial interface 1	263
Table 3-115: Application - standard values - configure RS-485 interface: serial interface 2.....	264
Table 3-116: Application - standard values - configure <i>LogicsManager</i>	265
Table 3-117: Internal flags - parameter IDs	265
Table 3-118: Application - standard values - configure counters.....	268
Table 3-119: <i>LogicsManager</i> - command overview	273
Table 3-120: <i>LogicsManager</i> - logical symbols.....	274
Table 3-121: Relay outputs - terminal assignment.....	278
Table 3-122: Analog Manager - display value format.....	309
Table 3-123: Event history - event list	320
Table 3-124: Event history - alarm list.....	322
Table 3-125: Analog inputs - characteristics diagram VDO 0 to 5 bar, Index "III"	329
Table 3-126: Analog inputs - characteristics diagram VDO 0 to 10 bar, Index "IV"	330
Table 3-127: Analog inputs - characteristics diagram VDO 40 to 120 °C, Index "92-027-004".....	331
Table 3-128: Analog inputs - characteristics diagram VDO 50 to 150 °C, Index "92-027-006".....	332
Table 3-129: Analog inputs - characteristics diagram Pt100.....	333

Chapter 1. General Information

Document Overview



Type	English	German
easYgen-2000 Series		
easYgen-2000 Series - Installation	37426	DE37426
easYgen-2000 Series - Configuration	this manual ⇔	DE37427
easYgen-2000 Series - Operation	37428	DE37428
easYgen-2000 Series - Application	37429	-
easYgen-2000 Series - Interfaces	37430	-
easYgen-2000 Series - Parameter List	37431	DE37431
easYgen-2000 Series - Brief Operation Information	37432	DE37432

Table 1-1: Manual - overview

Intended Use The unit must only be operated for the uses described in this manual. The prerequisite for a proper and safe operation of the product is correct transportation, storage, and installation as well as careful operation and maintenance.



NOTE

This manual has been developed for a unit fitted with all available options. Inputs/outputs, functions, configuration screens and other details described, which do not exist on your unit may be ignored. The present manual has been prepared to enable the configuration of the unit. On account of the large variety of parameter settings, it is not possible to cover every possible combination. The manual is therefore only a guide. In case of incorrect entries or a total loss of functions, the default settings can be taken from the Parameter List 37431 or from ToolKit and the respective *.SID file.



NOTE

Some parameters, inputs, and outputs are dependent on the configured application mode (parameter 3401 on page 141) regarding their availability and/or function. The following abbreviations indicate the application mode for which the concerned information is valid:

- {0} {0 (breaker control)} Application mode setting "None" - "Measuring transducer and engine control function"
The control unit enables engine start/stop and generator measuring and protection – no breaker control.
- {1o} {1 (breaker) open} Application mode setting "GCB open" - "1 breaker control function"
The control unit enables engine start/stop and generator measuring and protection – "GCB open" breaker control.
- {1oc} {1 (breaker) open/close} Application mode setting "GCB" - "1 breaker control function"
The control unit enables engine start/stop and generator measuring and protection – full generator breaker control for stand-by power applications with soft generator load transfer.
- {2oc} {2 (breaker) open/close} Application mode setting "GCB/MCB" - "2 breaker control function"
The control unit enables engine start/stop and generator measuring and protection – full generator breaker control for stand-by power applications with soft generator load transfer plus emergency power, open/closed transition, and interchange load transfer applications.

Abbreviations



The following abbreviations are frequently used throughout this and all other easYgen manuals:

CB	Circuit Breaker
CL	Code Level
CT	Current Transformer
CCW	Counter-Clockwise
CW	Clockwise
DI	Discrete Input
DO	Discrete (Relay) Output
ECU	Engine Control Unit
GCB	Generator Circuit Breaker
IOP	Isolated Operation in Parallel
LDSS	Load-Dependent Start/Stop operation
MCB	Mains Circuit Breaker
MOP	Mains Operation in Parallel
MPU	Magnetic Pickup Unit
N.C.	Normally Closed (break) contact
N.O.	Normally Open (make) contact
PF	Power Factor
PID	Proportional Integral Derivative controller
PLC	Programmable Logic Control
P/N	Part Number
PT	Potential (Voltage) Transformer
S/N	Serial Number

Chapter 2. Configuration



Configuration Via The Front Panel



Operation of the unit via the front panel is explained in the operation manual 37428. This manual will familiarize you with the unit, the meanings/functions of the buttons, and the display.

Configuration Using The PC



Install ToolKit Configuration and Visualization Software



CAUTION

Woodward's ToolKit software (version 3.1 or higher) is required when configuring the unit via a PC.
Toolkit from 3.1

If not already installed, download and install the ToolKit software. Please proceed as follows for this:

- Open your web browser and go to <http://www.woodward.com/software/>
- Select ToolKit in the list and click the Go button
- Download and install the file as described on the download page

Minimum system requirements for installing ToolKit:

- Microsoft Windows® Vista, XP
- Microsoft .NET Framework Ver. 3.5
- 600 MHz Pentium® CPU
- 96 MB of RAM
- Minimum 800 by 600 pixel screen with 256 colors
- Serial Port



NOTE

Please note that you must register on the website prior to downloading the software.

Microsoft .NET Framework 3.5 must be installed on your computer to be able to install ToolKit. If not already installed, Microsoft .NET Framework 3.5 will be installed automatically. You must be connected to the internet for this.



NOTE

If your computer is equipped with a Bluetooth interface please deactivate it temporary for the case that ToolKit is freezing building up a connection.

Configure ToolKit

Open ToolKit via Start menu -> Program -> Woodward -> ToolKit 3.x

You may configure the default settings of ToolKit by selecting Tools -> Options from the toolbar. The options window will be displayed where you may select the default COM port and the default path for the configuration files. We recommend configuring a dedicated ToolKit data file directory (e.g. C:\Data\ToolKit) instead of storing the configuration files in the ToolKit installation directory (e.g. C:\Program Files\Woodward\ToolKit). The changes become effective after restarting ToolKit.

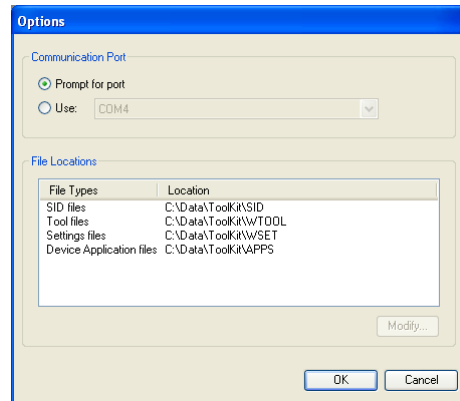

Figure 2-1: ToolKit - Options window



NOTE

Be sure to have the correct *.SID and *.WTOOL files for your unit ready. The SID file must not be renamed!

When installing the *.SID and *.WTOOL files on a computer, it is recommended to create a dedicated ToolKit data file external to the ToolKit program. An example of this would be to create a Woodward ToolKit folder in a Data directory to store the *.SID and *.WTOOL files. The data files should be kept separate from the program files. Mixing data and program files makes backing up files more difficult and uninstalling the files incomplete.

ToolKit Files

ToolKit is using the following files:

*.WTOOL

File name composition: [P/N1]-[Revision]_[Language ID]_[P/N2]-[Revision]_[# of visualized gens].WTOOL

Example file name: 8440-1884-NEW_US_5418-3090-NEW_32.WTOOL

Content of the file: Display screens and pages for online configuration, which are associated with the respective *.SID file

*.SID

File name composition: [P/N2]-[Revision].SID

Example file name: 5418-3090-NEW.SID

Content of the file: All display and configuration parameters available in ToolKit

*.WSET

File name composition: [user defined].WSET

Example file name: easYgen_settings.WSET

Content of the file: Default settings of the ToolKit configuration parameters provided by the SID file or user-defined settings read out of the unit.

P/N1 = Part number of the unit

P/N2 = Part number of the software in the unit



NOTE

The P/N2 and revision information in the *.SID file name is used for identifying the unit and must not be renamed.

When opening a *.WTOOL file, ToolKit will look for the respective SID file in the SID file location, configured in the Options dialog (refer to Figure 2-1).

The *.SID files have identical names regardless of the language and are located in the respective language folders delivered with the unit. If it happens that you need to switch between different languages in ToolKit, we recommend to store your *.SID (and *.WTOOL & *.WSET) files in different folders to avoid confusion. In this case you only need to change the path information as described under Configure ToolKit on page 16 to switch the language. Refer to the Language-Dependent SID Files section on page 18 for more details.

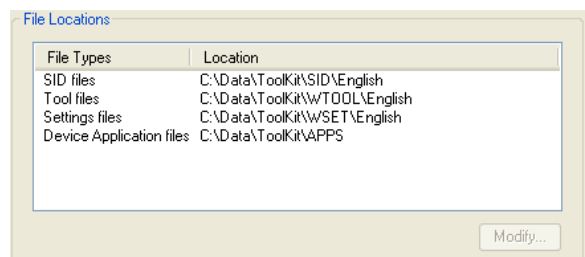

Language-Dependent SID Files

Every language comes with a separate *.sid file. At the moment, only English and German are provided. Due to current internal structures the *.sid files for every specific language have the same file name.

Therefore, a user will only be able to check the language by opening the *.sid file using an editor. Another possibility is to select New from SID defaults from the Settings menu in ToolKit. If you select the respective *.sid file then, a Settings Editor window opens, which displays the language ID ("us" or "de") in the title.

If a "German" version of *.wtool (8440-1884-NEW_de_5418-3090-NEW_32.wtool) tries to open an English *.sid file, error messages and a red cross are displayed on the screen upon connecting.

If it is required that both language versions of the *.sid file are stored on the computer, because the user wants to be able to switch between the languages, the *.sid files need to be stored in separate subfolders and the subfolder name needs to show the name of the appropriate language.

If the user needs to change the language, the appropriate *.sid file needs to be selected by using the ToolKit menu Tools -> Options -> SID file directories. The folder with the desired language needs to be on top position. ToolKit needs to be closed and the *.wtool file must be opened again, to ensure that the new *.sid file will be loaded.

SID Files for Using ToolKit on the CAN Bus With Other CANopen Devices

If a PC with ToolKit is connected to the easYgen via a CAN bus with other external CANopen devices (like a Phoenix Contact I/O expansion board, for example), it may happen that ToolKit cannot establish a connection with the easYgen because it looks for a SID file for such an external device, which does not exist.

A special *.sid file can be created in this case. Contact Woodward for support or create a *.sid file with the following content:

```
<?xml version="1.0" encoding="utf-8"?>
<ServiceInterfaceDefinition xmlns:xsi="http://www.w3.org/2001/XMLSchema-instance" Identifier="[add the
required device application name here]" Specification="EmptyFile">
</ServiceInterfaceDefinition>
```

The file name must be the same as the Identifier plus the extension *.sid. The file must be stored to the configured SID file directory.

Loading WSET Files of Previous Revisions

There may be incompatibilities between different easYgen P/Ns and revisions of the same P/N when loading a *.wset file, saved from an easYgen into an easYgen with a different P/N and/or revision. Proceed as follows to avoid that settings may get lost or transferred incorrectly:



Select from the ToolKit menu Settings -> Save from Device to File... to store the current easYgen settings (note that the correct *.sid file is available). Then select from the ToolKit menu Settings -> Load Settings File to Device... to load the stored settings into a different easYgen (take care that you provide the correct *.sid file in the same language that was used to store the *.wset file). If the P/Ns and/or revisions of the easYgens differ, you will be prompted to resolve the differences. If you are sure that the *.wset file is compatible with the easYgen, proceed with Next. If you are not sure, proceed with Resolve Differences (please note that this feature is not supported properly by the CANopen driver). If you select Resolve Differences it may take some minutes until the next window opens, because ToolKit reads out all settings from the device to compare them with those in the *.wset file. Then, a Compare Differences window will open and display all differences in value and/or parameter name. Most of the name differences can be mapped according to the same index number within the parameter name. Settings of parameters with selectable options cannot be mapped.

Verify all settings after loading them into the different easYgen! To verify the settings save them again from the easYgen to a *.wset file. Then select from the ToolKit menu Settings -> Compare Settings File Differences and open both, the (old) *.wset file loaded into the easYgen before, and the newly saved *.wset file. If there are no value differences displayed, the load process was successful. If there are any value differences, take care that they will be adjusted properly.

If there are any name differences, take care that the settings of the new parameters will be verified to fit the application purpose.

Connect ToolKit and the easYgen Unit

For configuration of the unit via ToolKit please proceed as follows:

- Connect the null modem communications cable between your laptop/PC and the DPC cable. Plug the null modem cable into the RS-232 serial port of the DPC cable and the other side to a serial COM port of the laptop/PC. If the laptop/PC does not have a serial port to connect the null modem cable to, use a USB to serial adapter. Now connect the DPC cable to the easYgen-2000.
- Open ToolKit via Start menu -> All Programs -> Woodward -> ToolKit 3.x
- From the main ToolKit window, click File then select Open Tool..., or click the Open Tool icon  on the tool bar.
- Locate and select the desired tool file (*.WTOOL) in the ToolKit data file directory and click Open.
- From the main ToolKit window, click Device then click Connect, or select the Connect icon  on the toolbar.
- The Connect dialog window will open if the option is enabled.
- Select the COM port that is connected to the communication cable.
- Click the OK button.
- If the Communications window opens, select ToolConfigurator under Tool Device and close the Communications window.
- The identifier of the device that ToolKit is connected to will display in the status bar.
- Now you are able to edit the easYgen parameters. Any changes made are written to the control memory automatically.



NOTE

A null modem serial cable must be used for communicating with the easYgen-2000 Series to ensure that the controller functions properly. The connection will not work if you are using a straight cable (a null modem cable has crosslinked transmit and receive lines in contrast to a straight serial cable).



NOTE

Depending on the computer used and the installed operation system, problems with the communication via an infrared connection may occur.



NOTE

It is also possible to connect to the unit via CAN bus. If a suitable CAN adapter is used, this may be selected in the Connect window. We recommend to use the IXXAT USB-to-CAN converter using the VCI V3 driver.

Be sure to configure the correct baud rate and timeout in the Properties dialog of the Connect window.

The Password for CAN Interface 1 (parameter 10402 on page 32) must be entered before being able to edit the parameters.

View easYgen Data with ToolKit

The following figure shows a visualization screen of ToolKit:

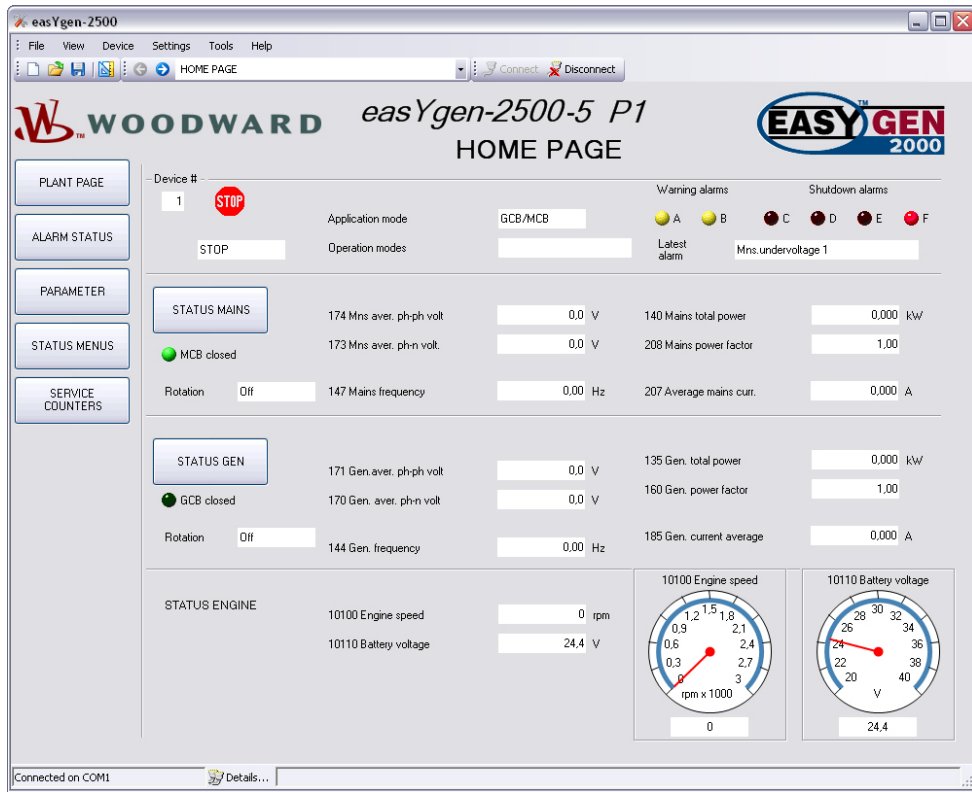



Figure 2-2: ToolKit - visualization screen

Navigation through the various visualization and configuration screens is performed by clicking on the  and  icons, by selecting a navigation button, or by selecting a screen from the drop-down list to the right of the arrow icons.

It is possible to view a trend chart of up to eight values with the trending tool utility of ToolKit. The following figure shows a trending screen of the measured battery voltage value:

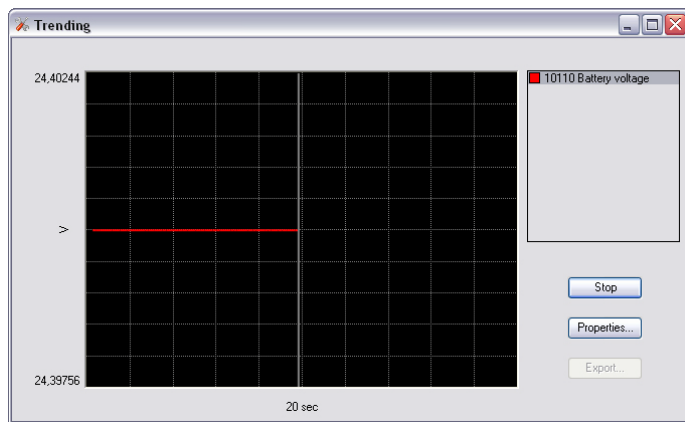

Figure 2-3: ToolKit - analog value trending screen

Each visualization screen provides for trending of monitored values by right-clicking on a value and selecting the "Add to trend" function. Trending is initiated by clicking on the Start button. Clicking the Export... button will save the trend data to a Comma Separated Values (CSV) file for viewing, editing or printing with office software, like Microsoft Excel, etc. The Properties... button is used to define high and low limits of the scale, sample rate, displayed time span and color of the graph. The trend functionality is not available if ToolKit is used utilizing a CAN bus connection to the unit.

Configure the easYgen with ToolKit

The following figure shows a configuration screen of ToolKit:

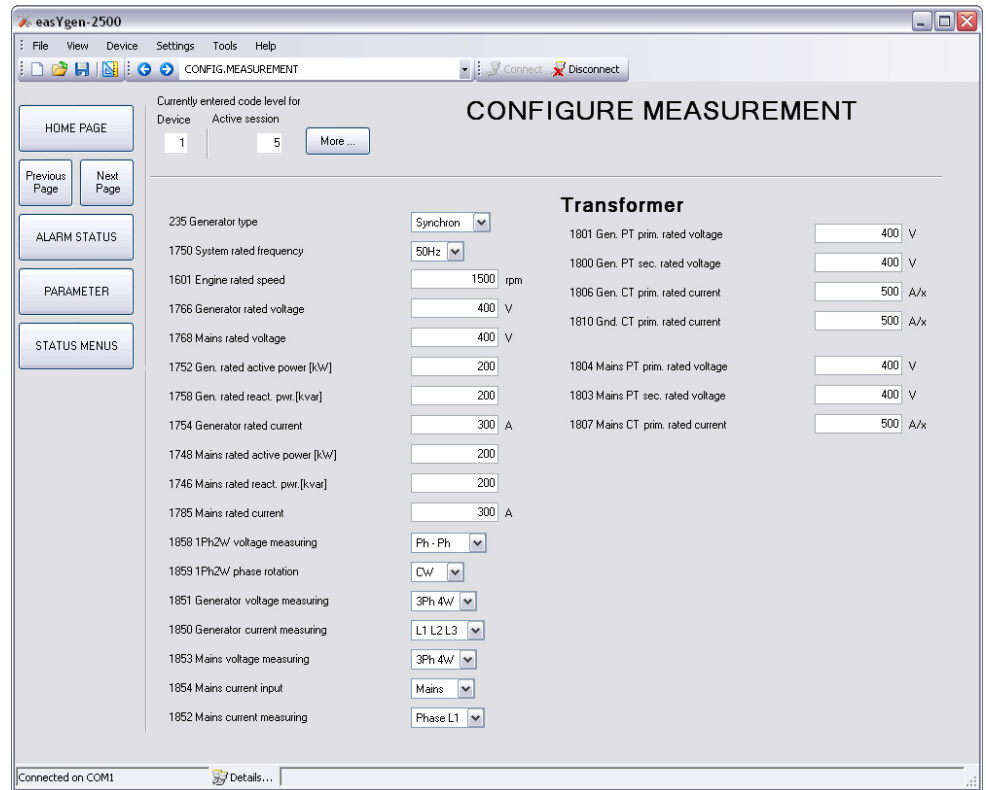



Figure 2-4: ToolKit - configuration screen

Entering a new value or selecting a value from a defined list will change the value in a field. The new value is written to the controller memory by changing to a new field or pressing the Enter key.

Navigation through the various configuration and visualization screens is performed by clicking on the  and  icons, by selecting a navigation button, or by selecting a screen from the drop-down list to the right of the arrow icons.

The Settings File Function of ToolKit

ToolKit allows you to manage device application settings as well as file based settings.

To create a settings file you can save a devices' settings to a file or create device settings from application (SID) defaults.

After you have a settings file, you can view and edit it, compare it to another settings file, associate it with a different application, or merge it with an application file (OH2 only).

Settings files can be exported to a Hypertext Markup Language (html) file for viewing, editing or printing with office software, like Microsoft Excel, etc.

Refer to the ToolKit Help for a description of working with settings. From the main ToolKit window, click Help then click Help Contents to open the ToolKit Help window.

Function of the Inputs and Outputs



Discrete Inputs

The discrete inputs may be grouped into two categories:

- programmable**
 The discrete input has been assigned a default function using either the *LogicsManager* or preconfigured alarms such as "emergency stop". The following text describes how these functions are assigned. It is possible to change the function of the discrete input if required.
 The following description of the inputs, labeled with *programmable*, refers to the preconfiguration.
- fixed**
 The discrete input has a specific function that cannot be changed depending upon the configured application mode.

Emergency stop {0}, {1o}, {1oc}, or {2oc} *programmable*, pre-configured for discrete input [DI 1], terminals 43/44
 This discrete input is configured as alarm class F and is not delayed by the engine speed.

Start request in AUTO {0}, {1o}, {1oc}, or {2oc} *programmable*, pre-configured for discrete input [DI 2], terminals 43/45
 Enabled in the AUTOMATIC operation mode
energized..... If the unit is in the AUTOMATIC operation mode (selected with the operating mode selection push button on the front panel) the controlled engine is started automatically.
de-energized The engine is stopped.
 This discrete input is configured as a Control input in the alarm class and is not delayed by the engine speed.

Low oil pressure {0}, {1o}, {1oc}, or {2oc} *programmable*, pre-configured for discrete input [DI 3], terminals 43/46
 This discrete input is configured as alarm class B and is delayed by the engine speed.

Coolant temperature {0}, {1o}, {1oc}, or {2oc} *programmable*, pre-configured for discrete input [DI 4], terminals 43/47
 This discrete input is configured as alarm class B and is not delayed by the engine speed.

External acknowledgement {0}, {1o}, {1oc}, or {2oc} *programmable*, pre-configured for discrete input [DI 5], term. 43/48
 This discrete input is used as a remote acknowledgement for alarms. The input is normally de-energized. When an alarm is to be acknowledged the input is energized. The first time an alarm is acknowledged, the centralized alarm/horn is silenced. When the input is energized a second time, all alarms, which are no longer active, will be acknowledged.
 This discrete input is configured as a Control input in the alarm class and is not delayed by the engine speed.

Release MCB {2oc} *programmable*, pre-configured for discrete input [DI 6], terminals 43/49
energized..... The MCB is enabled and closure of the breaker is permitted.
de-energized The MCB is not enabled and closure of the breaker is not permitted. This function permits a supervisory control (i.e. a PLC) to allow the closure of the MCB by the easYgen.
 This discrete input is configured as a Control input in the alarm class and is not delayed by the engine speed.

Reply MCB {2oc}*programmable*, pre-configured to discrete input [DI 7], terminals 43/50⇒ **Note: Negative logic function!**

The controller utilizes the CB auxiliary (B) contacts into this discrete input to reflect the state of the MCB. This discrete input must be energized to show when the breaker is open and de-energized to show when the MCB is closed. The status of the MCB is displayed on the screen.

This input is used in all breaker modes to change between frequency/voltage and power/power factor control (refer to below note).

Reply GCB {1oc} or {2oc}*fixed* to discrete input [DI 8], terminals 43/51⇒ **Note: Negative function logic!**

The controller utilizes the CB auxiliary (B) contacts into this discrete input to reflect the state of the GCB. This discrete input must be energized to show when the breaker is open and de-energized to show when the GCB is closed. The status of the GCB is displayed on the screen.

This input is used in all breaker modes to enable reverse power protection, overload MOP protection, mains decoupling and the activation of the load sharing (refer to below note).

Discrete Input 9 {0}, {1o}, {1oc}, or {2oc}*programmable*, pre-configured for discrete input [DI 9], terminals 75/76

This discrete input is configured as alarm class B and is not delayed by the engine speed.

Discrete Input 10 {0}, {1o}, {1oc}, or {2oc}*programmable*, pre-configured for discrete input [DI 10], terminals 75/77

This discrete input is configured as alarm class B and is not delayed by the engine speed.

**NOTE**

The easYgen decides whether it performs voltage and frequency (V/f) control or power and power factor (P/PF) control using the reply of the circuit breakers, i.e. the discrete inputs DI 7 and DI 8.

If the GCB is open, only V/f control is performed

If the GCB is closed and the MCB is open, V/f control as well as active and reactive power load sharing is performed

If the GCB is closed and the MCB is closed, P/PF control or import power control with load sharing and PF control is performed.

Alarm inputs {0}, {1o}, {1oc}, or {2oc}

All discrete inputs, which are not assigned a function, can be used as alarm or control inputs. These discrete inputs can be freely configured as such. Refer to the section "Configure Discrete Inputs" on page 168.

Discrete Outputs

The discrete outputs can be grouped into two categories:

- **programmable**
The discrete output has been assigned a default function using the *LogicsManager*. The following text describes how these functions are assigned using the *LogicsManager*. It is possible to change the function of the discrete output if required.
The following description of the outputs, labeled with *programmable*, refers to the preconfiguration.
- **fixed**
The discrete output has a specific function that cannot be changed depending upon the configured application mode. The discrete output cannot be viewed or changed in the *LogicsManager*.



NOTE

The discrete outputs can be "*programmable*" or "*fixed*" depending on the application mode (parameter 3401 on page 141). Table 3-78 on page 172 defines the function of the discrete outputs according to the configured application mode.

Ready for operation OFF {0}, {1o}, {1oc}, or {2oc}

fixed to relay [R1], terminals 30/31

This discrete output is used to ensure that the internal functions of the controller are operating properly. It is possible to configure additional events, which cause the contacts of this discrete output to open, using the *LogicsManager*.



CAUTION

The discrete output "Ready for operation OFF" must be wired in series with an emergency stop function. This means that it must be ensured that the generator circuit breaker is opened and the engine is stopped if this discrete output is de-energeized. We recommend to signal this fault independently from the unit if the availability of the plant is important.

Centralized alarm {0}, {1o}, {1oc}, or {2oc}

programmable to relay [R2], terminals 32/33

When a centralized alarm is issued, this discrete output is enabled. A horn or a buzzer maybe activated via this discrete output. Pressing the button next to the "✓" symbol will acknowledge the centralized alarm and disable this discrete output. The discrete output will re-enable if a new fault condition resulting in a centralized alarm occurs. The centralized alarm is initiated by class B alarms or higher.

Starter {0}, {1o}, {1oc}, or {2oc}

programmable to relay [R3], terminals 34/35

The generator starting circuit is engaged when this discrete output is enabled. This discrete output will enable depending on the start sequence (refer to the start sequence description in the Configure Application: Configure Engine section starting on page 178) to energize the starter for the configured starter time (parameter 3306 on page 184).

Fuel solenoid / gas valve (Diesel / gas engine) {0}, {1o}, {1oc}, or {2oc}

programmable to relay [R4], terminals 36/37

Fuel solenoid: The fuel solenoid for the diesel engine is energized when this discrete output is enabled. If the engine is given a stop command or engine speed drops below the configured firing speed, this discrete output is disabled immediately.

Gas valve: The gas valve for the engine is energized when this discrete output is enabled. If the engine is given a stop command or engine speed drops below the configured firing speed, this discrete output is disabled immediately.

Open MCB {2oc}

fixed to relay [R5], terminals 38/40

The controller enables this discrete output when the MCB is to be opened for switching operations.



CAUTION

The circuit breaker commands must be checked before every commissioning because the relays can be used for different applications and can be assigned to various functions. Please make sure that all relay outputs are configured correctly.

Command: close GCB {1oc} or {2oc}*fixed* to relay [R6], terminals 41/42

The "Command: close GCB" output issues the signal for the GCB to close. This relay may be configured as an impulse or constant output signal depending on parameter 3414 on page 152.

If the output is configured as "Impulse", the discrete output will enable for the time configured in parameter 3416 on page 152). An external holding coil and sealing contacts must be installed into the GCB closing circuit if this discrete output is configured for an impulse output signal.

If the relay is configured as "Constant", the relay will energize and remain enabled as long as the discrete input "Reply GCB" remains de-energized and the generator and busbar voltages are identical. If a class C or higher alarm occurs, this discrete will disable and the GCB will open immediately.

Command: open GCB {1o}, {1oc}, or {2oc}*fixed* to relay [R7], terminals 80/81

The parameter 3403 on page 151 defines how this relay functions. If this parameter 3403 is configured as "N.O.", the relay contacts close resulting in the GCB opening circuit energizing. If this output is configured as "N.C.", the relay contacts open resulting in the GCB opening circuit de-energizing. If the controller is configured for the breaker application "None", this relay is freely configurable.

{1o}: The open GCB command remains enabled until the GCB is manually closed and the discrete input "Reply GCB" is energized. The open GCB command will be issued when a fault condition or an engine shut down occurs.

{1oc} or {2oc}: The controller enables the open GCB command when the GCB is to be opened for switching operations. If the discrete input "Reply GCB" is energized, the open GCB command will be disabled.

Command: close MCB {2oc}*fixed* to relay [R8], terminals 82/83

The discrete output "Command: close MCB" is an impulse output signal. This discrete output is enabled for the time configured in parameter 3417 on page 155. An external holding coil and sealing contacts must be utilized with the MCB closing circuit.

Stop solenoid {2oc}*programmable*, pre-configured to relay [R9], terminals 84/85

Inverted function of **Fuel solenoid / gas valve** (preconfigured [R4])

Auxiliary services {0}, {1o}, {1oc}, or {2oc}*programmable*, pre-configured to relay [R10], terminals 86/87

The auxiliary services output (*LogicsManager* 03.01) will be enabled with the start command (prior to the engine start because of the prerun time) and remains enabled as long as the engine is running. It will be disabled after the engine has stopped and the postrun time has expired (i.e. for operating a cooling pump). Refer to Figure 3-24 on page 188 for this behavior.

The auxiliary services output (*LogicsManager* 03.01) is always enabled in MANUAL operation mode.

Shutdown alarm {0}, {1o}, {1oc}, or {2oc}*programmable*, pre-configured to relay [R11], terminals 88/89

This discrete output is enabled when a shutdown alarm (class C or higher alarm; refer to Alarm Classes on page 271 for more information) is issued. After all shutdown alarms have been acknowledged, this discrete output will disable.

Chapter 3. Parameters

All parameters are assigned a unique Parameter Identification Number. The Parameter Identification Number may be used to reference individual parameters listed in this manual. This Parameter Identification Number is also displayed in the ToolKit configuration screens next to the respective parameter.

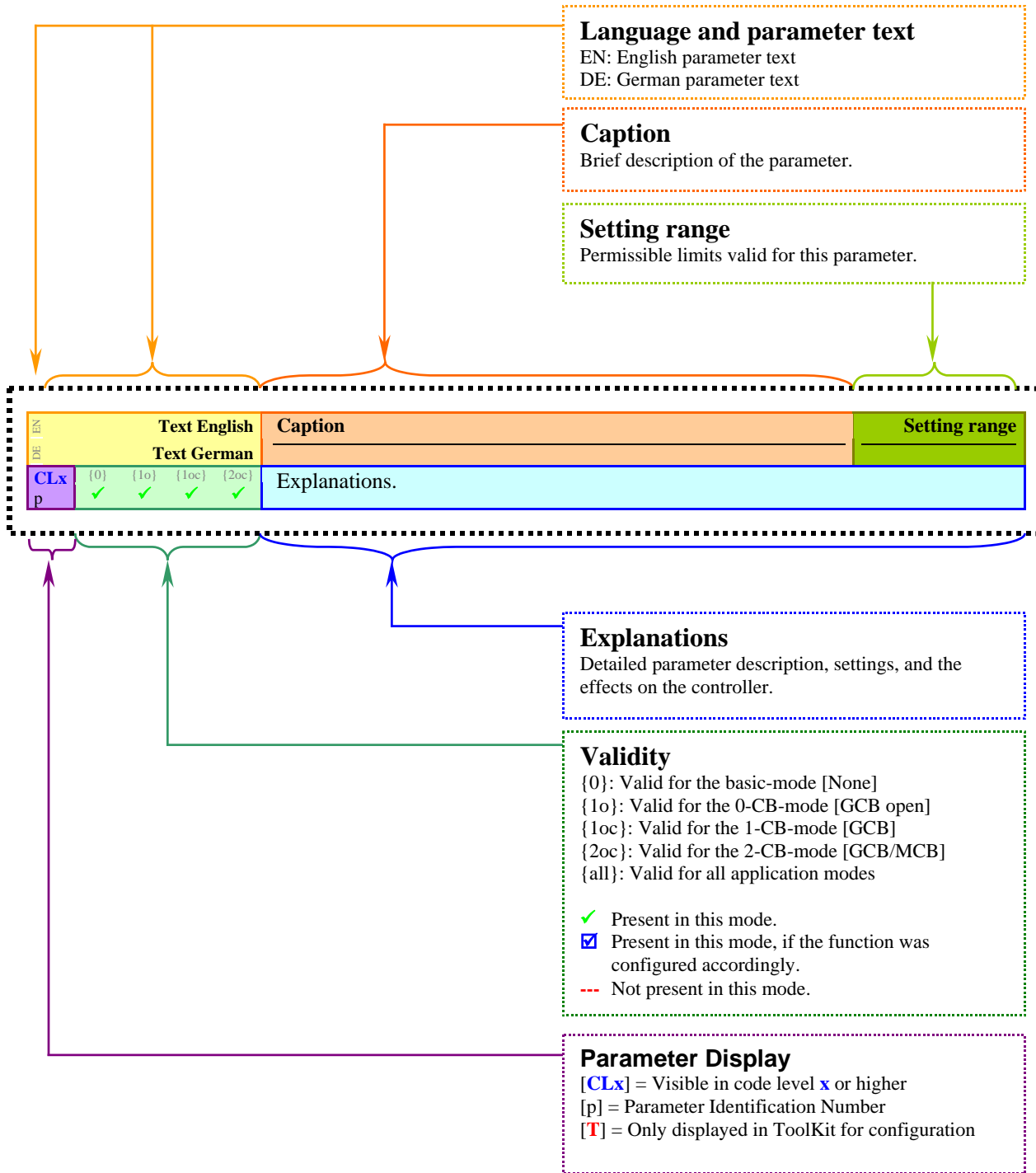

Configure Language / Clock



The following parameters are used to set the unit language, the current date and time, and the daylight saving time feature.

Parameter Table

Level	Text	Setting range	Default value
Configure language / clock			
	Language	English / Deutsch / Italiano / Français / Español / Türkçe / Russky / Japanese / Protuguês / Chinese / Polish	English
	Hour	0 to 23 h	(real-time clock)
	Minute	0 to 59 min	(real-time clock)
	Second	0 to 59 s	(real-time clock)
	Day	1 to 31	(real-time clock)
	Month	1 to 12	(real-time clock)
	Year	0 to 99	(real-time clock)
	Daylight saving time	On / Off	Off
	DST begin time	0 to 23	2
	DST begin weekday	Sunday / Monday / Tuesday / Wednesday / Thursday / Friday / Saturday	Sunday
	DST begin nth weekday	1st / 2nd / 3rd / 4th / Last / LastButOne / LastButTwo / LastButThree	4th
	DST begin month	1 to 12	3
	DST end time	0 to 23	3
	DST end weekday	Sunday / Monday / Tuesday / Wednesday / Thursday / Friday / Saturday	Sunday
	DST end nth weekday	1st / 2nd / 3rd / 4th / Last / LastButOne / LastButTwo / LastButThree	4th
	DST end month	1 to 12	10

Table 3-1: Configuration - standard values - configure language/clock

EN DE	Language Language	Set language	selectable languages
CL0 1700	{0} {10} {10c} {20c}	The desired language for the unit display text is configured here.	



NOTE

If an Asian language is configured, some parameter screens may be displayed with an empty space at the bottom of the parameter list, which may be interpreted as an end of the list, although more parameters exist and are displayed when scrolling down.

EN DE	Hour Stunden	Adjust clock: hour	0 to 23 h
CL0 1710	{0} {10} {10c} {20c}	The hour of the clock time is set here. Example: 0..... 0 th hour of the day (midnight). 23..... 23 rd hour of the day (11 pm).	

EN DE	Minute Minuten	Adjust clock: minute	0 to 59 min
CL0 1709	{0} {10} {10c} {20c}	The minute of the clock time is set here. Example: 0..... 0 th minute of the hour. 59..... 59 th minute of the hour.	

EN	Second	Adjust clock: second	0 to 59 s
DE	Sekunden		
CL0	{0} {1o} {1oc} {2oc}	The second of the clock time is set here. Example:	
1708	✓ ✓ ✓ ✓	00 th second of the minute.	
		5959 th second of the minute.	

EN	Day	Adjust clock: day	1 to 31
DE	Tag		
CL0	{0} {1o} {1oc} {2oc}	The day of the date is set here. Example:	
1711	✓ ✓ ✓ ✓	11 st day of the month.	
		3131 st day of the month.	

EN	Month	Adjust clock: month	1 to 12
DE	Monat		
CL0	{0} {1o} {1oc} {2oc}	The month of the date is set here. Example:	
1712	✓ ✓ ✓ ✓	11 st month of the year.	
		1212 th month of the year.	

EN	Year	Adjust clock: year	0 to 99
DE	Jahr		
CL0	{0} {1o} {1oc} {2oc}	The year of the date is set here. Example:	
1713	✓ ✓ ✓ ✓	0Year 2000.	
		99Year 2099.	

The daylight saving time feature enables to automatically adjust the real-time clock to local daylight saving time (DST) provisions. If daylight saving time is enabled, the real-time clock will automatically be advanced by one hour when the configured DST begin date and time is reached and falls back again by one hour when the configured DST end date and time is reached. If the unit is used in the southern hemisphere, the DST function will be inverted automatically, if the DST begin month is later in the year than the DST end month.



NOTE

Do not change the time manually during the hour of the automatic time change if DST is enabled to avoid a wrong time setting.

Events or alarms, which occur during this hour might have a wrong time stamp.

EN	Daylight saving time	Adjust clock: Enable daylight saving time	On / Off
DE	Sommerzeitumschaltung		
CL2	{0} {1o} {1oc} {2oc}	On.....Daylight saving time is enabled.	
4591	✓ ✓ ✓ ✓	OffDaylight saving time is disabled.	



NOTE

The following parameters will only be displayed, if Daylight saving time (parameter 4591) has been configured to On and the enter button has been pressed.

EN	DST begin time	Adjust clock: DST begin time	0 to 23 h
DE	Sommerzeitbeginn Uhrzeit		
CL2	{0} {1o} {1oc} {2oc}	The real-time clock will be advanced by one hour when this time is reached on the DST begin date. Example:	
4594	✓ ✓ ✓ ✓	00 th hour of the day (midnight).	
		2323 rd hour of the day (11 pm).	

EN	DST begin weekday				Adjust clock: DST begin weekday	<i>weekday</i>
DE	Sommerzeitbeginn Wochentag					
CL2	{0}	{1o}	{1oc}	{2oc}	The weekday for the DST begin date is configured here	
4598	✓	✓	✓	✓		

EN	DST begin nth. weekday				Adjust clock: DST begin n th weekday	<i>weekday order no.</i>
DE	Sommerzeitbeginn x. Wochentag					
CL2	{0}	{1o}	{1oc}	{2oc}	The order number of the weekday for the DST begin date is configured here.	
4592	✓	✓	✓	✓	Example:	
					1st DST starts on the 1 st configured weekday of the DST begin month.	
					2nd DST starts on the 2 nd configured weekday of the DST begin month.	
					3rd DST starts on the 3 rd configured weekday of the DST begin month.	
					4th DST starts on the 4 th configured weekday of the DST begin month.	
					Last DST starts on the last configured weekday of the DST begin month.	
					LastButOne . DST starts on the last but one configured weekday of the DST begin month.	
					LastButTwo DST starts on the last but two configured weekday of the DST begin month.	
					LastButThree .. DST starts on the last but three configured weekday of the DST begin month.	

EN	DST begin month				Adjust clock: DST begin month	1 to 12
DE	Sommerzeitbeginn Monat					
CL2	{0}	{1o}	{1oc}	{2oc}	The month for the DST begin date is configured here. Example:	
4593	✓	✓	✓	✓	1 1 st month of the year.	
					12 12 th month of the year.	

EN	DST end time				Adjust clock: DST end time	0 to 23 h
DE	Sommerzeitende Uhrzeit					
CL2	{0}	{1o}	{1oc}	{2oc}	The real-time clock will fall back by one hour when this time is reached on the DST end date. Example:	
4597	✓	✓	✓	✓	0 0 th hour of the day (midnight).	
					23 23 rd hour of the day (11 pm).	

EN	DST end weekday				Adjust clock: DST end weekday	<i>weekday</i>
DE	Sommerzeitende Wochentag					
CL2	{0}	{1o}	{1oc}	{2oc}	The weekday for the DST end date is configured here	
4599	✓	✓	✓	✓		

EN	DST end nth. weekday				Adjust clock: DST end n th weekday	<i>weekday order no.</i>
DE	Sommerzeitende x. Wochentag					
CL2	{0}	{1o}	{1oc}	{2oc}	The order number of the weekday for the DST end date is configured here.	
4595	✓	✓	✓	✓	Example:	
					1st DST ends on the 1 st configured weekday of the DST end month.	
					2nd DST ends on the 2 nd configured weekday of the DST end month.	
					3rd DST ends on the 3 rd configured weekday of the DST end month.	
					4th DST ends on the 4 th configured weekday of the DST end month.	
					Last DST ends on the last configured weekday of the DST end month.	
					LastButOne . DST ends on the last but one configured weekday of the DST end month.	
					LastButTwo DST ends on the last but two configured weekday of the DST end month.	
					LastButThree .. DST ends on the last but three configured weekday of the DST end month.	

EN	DST end month			
DE	Sommerzeitende Monat			
CL2	{0}	{1o}	{1oc}	{2oc}
4596	✓	✓	✓	✓

Adjust clock: DST end month

1 to 12

The month for the DST end date is configured here. Example:
11st month of the year.
1212th month of the year.

Example: If daylight saving time starts at 2:00 am on the 2nd Sunday in March and ends at 2:00 am on the 1st Sunday in November, the unit has to be configured like shown in Table 3-2 to enable an automatic change to daylight saving time and back to standard time.

ID	Parameter	Setting
4591	Daylight saving time	On
4594	DST begin time	2
4598	DST begin weekday	Sunday
4592	DST begin nth weekday	2nd
4593	DST begin month	3
4597	DST end time	2
4599	DST end weekday	Sunday
4595	DST end sunday	1st
4596	DST end month	11

Table 3-2: Daylight saving time - configuration example

	USA, Canada		European Union	
Year	DST Begins 2 a.m. (Second Sunday in March)	DST Ends 3 a.m. (First Sunday in November)	DST Begins 1 a.m. UTC=GMT (Last Sunday in March)	DST Ends 2 a.m. UTC=GMT (Last Sunday in October)
2008	March 9, 2008	November 2, 2008	March 30, 2008	October 26, 2008
2009	March 8, 2009	November 1, 2009	March 29, 2009	October 25, 2009
2010	March 14, 2010	November 7, 2010	March 28, 2010	October 31, 2010

Table 3-3: Daylight saving time - examplary dates

Configure Display



The contrast and the brightness of the display may be adjusted using this screen.

Lamp Test



All lights on the controller may be tested for correct operation with this function.

Enter Password



The easYgen-2000 Series utilizes a password protected multi-level configuration access hierarchy. This permits varying degrees of access to the parameters being granted by assigning unique passwords to designated personnel. A distinction is made between the access levels as follows:

Code level CL0 (User Level) Standard password = none
 This code level permits for monitoring of the system and limited access to the parameters. Configuration of the control is not permitted. Only the parameters for setting the language, the date, the time, and the horn reset time are accessible. The unit powers up in this code level.

Code level CL1 (Service Level) Standard password = "0 0 0 1"
 This code level entitles the user to change selected non-critical parameters, such as setting the parameters accessible in CL0 plus Bar/PSI, °C/°F. The user may also change the password for level CL1. Access granted by this password expires two hours after the password has been entered and the user is returned to the CL0 level.

Code level CL2 (Temporary Commissioning Level) No standard password available
 This code level grants temporary access to most of the parameters. The password is calculated from the random number generated when the password is initially accessed. It is designed to grant a user one-time access to a parameter without having to give him a reusable password. The user may also change the password for level CL1. Access granted by this password expires two hours after the password has been entered and the user is returned to the CL0 level. The password for the temporary commissioning level may be obtained from the vendor.

Code level CL3 (Commissioning Level) Standard password = "0 0 0 3"
 This code level grants complete and total access to most of the parameters. In addition, the user may also change the passwords for levels CL1, CL2 and CL3. Access granted by this password expires two hours after the password has been entered and the user is returned to the CL0 level.



NOTE

Once the code level is entered, access to the configuration menus will be permitted for two hours or until another password is entered into the control. If a user needs to exit a code level then code level, CL0 should be entered. This will block unauthorized configuration of the control. A user may return to CL0 by allowing the entered password to expire after two hours or by changing any one digit on the random number generated on the password screen and entering it into the unit.

It is possible to disable expiration of the password by entering "0000" after the CL1 or CL3 password has been entered. Access to the entered code level will remain enabled until another password is entered. Otherwise, the code level would expire when loading the standard values (default 0000) via ToolKit.

Parameter Table

Level	Text	Setting range	Default value
Configure password			
	Password display	0 to 9999	random number
	Code level display	(display only)	0
	Password for CAN interface 1	0 to 9999	random number
	Code level CAN interface 1	(display only)	0
	Password for CAN interface 2	0 to 9999	random number
	Code level CAN interface 2	(display only)	0
	Password for serial interface 1	0 to 9999	random number
	Code level serial interface 1	(display only)	0
	Password for serial interface 2	0 to 9999	random number
	Code level serial interface 2	(display only)	0

Table 3-4: Configuration - standard values - enter password

Figure 3-1 shows a configuration menu screen in code level CL0 (left) and CL1 (right).



Figure 3-1: Code level display

EN		Password display	Password: Entry via front panel	0000 to 9999
DE		Passwort Display		
CL0	{0}	{10}	{10c}	{20c}
10400	✓	✓	✓	✓
The password for configuring the control via the front panel must be entered here.				
EN		Code level display	Password system: Code level via display	Info
DE		Codeebene Display		
CL0	{0}	{10}	{10c}	{20c}
10405	✓	✓	✓	✓
This value displays the code level, which is currently enabled for access via the front panel display.				
EN		Password for CAN interface 1	Password: Entry via CAN interface #1	0000 to 9999
DE		Passwort CAN Schnittstelle 1		
CL0	{0}	{10}	{10c}	{20c}
10402	✓	✓	✓	✓
The password for configuring the control via the CAN interface #1 must be entered here.				
EN		Code level CAN interface 1	Password system: Code level via CAN interface #1	Info
DE		Codeebene CAN Schnittstelle 1		
CL0	{0}	{10}	{10c}	{20c}
10407	✓	✓	✓	✓
This value displays the code level, which is currently enabled for access via the CAN interface #1s.				
EN		Password for CAN interface 2	Password: Entry via CAN interface #2	0000 to 9999
DE		Passwort CAN Schnittstelle 2		
CL0	{0}	{10}	{10c}	{20c}
10432	✓	✓	✓	✓
The password for configuring the control via the CAN interface #1 must be entered here.				
EN		Code level CAN interface 2	Password system: Code level via CAN interface #2	Info
DE		Codeebene CAN Schnittstelle 2		
CL0	{0}	{10}	{10c}	{20c}
10422	✓	✓	✓	✓
This value displays the code level, which is currently enabled for access via the CAN interface #1s.				
EN		Password for serial interface1	Password: Entry via serial interface #1	0000 to 9999
DE		Passwort serielle Schnittst. 1		
CL0	{0}	{10}	{10c}	{20c}
10401	✓	✓	✓	✓
The password for configuring the control via the serial interface #1 must be entered here.				
EN		Code level serial interface 1	Password system: Code level via serial RS-232 interface #1	Info
DE		Codeebene serielle Schnittst. 1		
CL0	{0}	{10}	{10c}	{20c}
10406	✓	✓	✓	✓
This value displays the code level, which is currently enabled for access via RS-232 serial interface #1.				
EN		Password for serial interface2	Password: Entry via serial interface 2	0000 to 9999
DE		Passwort serielle Schnittst. 2		
CL0	{0}	{10}	{10c}	{20c}
10430	✓	✓	✓	✓
The password for configuring the control via the serial interface #2 must be entered here.				
EN		Code level serial interface 2	Password system: Code level via serial RS-485 interface #2	Info
DE		Codeebene serielle Schnittst. 2		
CL0	{0}	{10}	{10c}	{20c}
10420	✓	✓	✓	✓
This value displays the code level, which is currently enabled for access via RS-485 serial interface #2.				

System Management



Parameter Table

Level	Text	Setting range	Default value
System management			
	Device number	1 to 32	1
	Configure display backlight	On / Key activate.	Key activate.
	Time until backlight shutdown	1 to 999 min	120 min
	Factory default settings	Yes / No	No
	Reset factory default values	Yes / No	No
	Start Bootloader	23130 to 23130	42405
	Clear eventlog	Yes / No	No

Table 3-5: Configuration - standard values - system management

EN	Device number			
DE	Gerätenummer			
CL2	{0}	{10}	{10c}	{20c}
1702	✓	✓	✓	✓

System parameter: Device address **1 to 32**

A unique address is assigned to the control through this parameter. This unique address permits the controller to be correctly identified on the CAN bus. The address assigned to the controller may only be used once. All other bus addresses are calculated on the number entered in this parameter. The device number is also important for the device assignment in load sharing and load-dependent start/stop.



NOTE

The unit must be restarted after changing the device number to ensure proper operation.

EN	Configure display backlight			
DE	Konfig. Display Beleuchtung			
CL0	{0}	{10}	{10c}	{20c}
4556	✓	✓	✓	✓

System parameter: Configure display backlight **On / Off / AUTO / Key activat.**

On The display backlight is always enabled.
Off..... The display backlight is always disabled.
AUTO The display backlight is automatically switched off to save battery energy, if no mains/busbar voltage is available.
Key activat. . The display backlight will be dimmed, if no soft key is pressed for the time configured in parameter 4557.

EN	Time until backlight shutdown			
DE	Zeit bis Abschaltung			
CL2	{0}	{10}	{10c}	{20c}
4557	✓	✓	✓	✓

System parameter: Time until backlight shutdown **1 to 999 min**

ⓘ This parameter is only effective, if parameter 4556 is configured to "Key activat."

If no soft key has been pressed for the time configured here, the display backlight will be dimmed.

EN	Factory default settings			
DE	Werkseinstellung			
CL0	{0}	{10}	{10c}	{20c}
1703	✓	✓	✓	✓

Factory settings: Restore default values **Yes / No**

Yes The following three parameters are visible and restoring the configured parameters to factory default values is enabled.
No..... The following three parameters are invisible and restoring the configured parameters to factory default values is not enabled.



NOTE

The following parameters will only be displayed, if Factory Settings (parameter 1703) has been configured to Yes and the enter button has been pressed.

EN	Reset factory default values			
DE	Standardwerte			
CL0 1701	{0} ✓	{1o} ✓	{1oc} ✓	{2oc} ✓

Factory settings: Set default values **Yes / No**

Yes.....All parameters, which the enabled access code grants privileges to, will be restored to factory default values.

NoAll parameters will remain as currently configured.

EN	Start Bootloader			
DE	Bootloader starten			
CL2 10500	{0} ✓	{1o} ✓	{1oc} ✓	{2oc} ✓

Factory settings: Start Bootloader **00000**

The bootloader is utilized for uploading application software only. The proper enable code must be entered while the control is in access code level CL3 or higher to perform this function.

Attention: This function is used for uploading application software and may only be used by authorized Woodward technicians!

EN	Clear eventlog			
DE	Ereignisspeicher löschen			
CL2 1706	{0} ✓	{1o} ✓	{1oc} ✓	{2oc} ✓

Factory settings: Clear event log **Yes / No**

Yes.....The event history will be cleared.

NoThe event history will not be cleared.

System Management: Password System

Parameter Table

Level	Text	Setting range	Default value
Password system			
	Basic code level	0 to 9999	-
	Commissioning code level	0 to 9999	-
	Temp. commissioning code level	0 to 9999	-
	Temp. supercomm. level code	0 to 9999	-
	Supercommissioning level code	0 to 9999	-

Table 3-6: Configuration - standard values - system management: password system



NOTE

The following passwords grant varying levels of access to the parameters. Each individual password can be used to access the appropriate configuration level through multiple access methods and communication protocols (via the front panel, via serial RS-232/485 interface, and via the CAN bus).

EN	Basic code level				Password system: Password "Service Level" (CL1)	0000 to 9999
DE	Code Serviceebene					
CL1	{0}	{1o}	{1oc}	{2oc}	The password for the code level "Service" is defined in this parameter. Refer to the Enter Password section on page 31 for default values.	
10415	✓	✓	✓	✓		
EN	Commissioning code level				Password system: Password "Commission" (CL3)	0000 to 9999
DE	Code Inbetriebnahme Ebene					
CL3	{0}	{1o}	{1oc}	{2oc}	The password for the code level "Commission" is defined in this parameter. Refer to the Enter Password section on page 31 for default values.	
10413	✓	✓	✓	✓		
EN	Temp. commissioning code level				Password system: Password "Temporary Commission" (CL2)	0000 to 9999
DE	Code temp. Inbetriebn. Ebene					
CL3	{0}	{1o}	{1oc}	{2oc}	The algorithm for calculating the password for the code level "Temporary Commissioning" is defined in this parameter.	
10414	✓	✓	✓	✓		
EN	Temp. supercomm. level code				Password system: Password "Temporary Supercommissioning" (CL4)	0000 to 9999
DE	Code temp. Supercomm. Ebene					
CL5	{0}	{1o}	{1oc}	{2oc}	The algorithm for calculating the password for the code level "Temporary Supercommissioning" is defined in this parameter.	
10412	✓	✓	✓	✓		
EN	Supercommissioning level code				Password system: Password "Supercommissioning" (CL5)	0000 to 9999
DE	Code Supercommissioning Ebene					
CL5	{0}	{1o}	{1oc}	{2oc}	The password for the code level "Supercommissioning" is defined in this parameter. Refer to the Enter Password section on page 31 for default values.	
10411	✓	✓	✓	✓		

Configuration



The configuration screen is accessed pressing the Configuration softkey on the Parameter screen. The following sub-menus are available to configure the unit:

- Configure Measurement
- Configure Monitoring
- Configure Application
- Configure Interfaces
- Configure *LogicsManager*
- Configure Counters



NOTE

This controller is available in two different hardware version with either 1A [./1] or 5A [./5] current transformer inputs. Both versions are discussed in this manual. The set points for specific parameters will differ depending upon the hardware version.



NOTE

It is absolutely essential that correct rated values to be entered when configuring the controller, as many measurement and monitoring functions refer to these values.

Configure Measurement



Parameter Table

Level	Text	Setting range	Default value
Configure measurement			
	Show mains data	Yes / No	Yes
	Generator type	Synchron / Asynchron	Synchron
	System rated frequency	50 / 60 Hz	50 Hz
	Engine rated speed	500 to 4000 rpm	1500 rpm
	Generator rated voltage	50 to 650000 V	400 V
	Mains rated voltage	50 to 650000 V	400 V
	Busbar 1 rated voltage	50 to 650000 V	400 V
	Gen. rated active power [kW]	0.5 to 99999.9 kW	200 kW
	Gen. rated react. power [kvar]	0.5 to 99999.9 kvar	200 kvar
	Generator rated current	1 to 32000 A	300 A
	Mains rated active power [kW]	0.5 to 99999.9 kW	200 kW
	Mains rated react. pwr. [kvar]	0.5 to 99999.9 kvar	200 kvar
	Mains rated current	5 to 32000 A	300 A
	1Ph2W voltage measuring	Phase - phase / Phase - neutral	Phase - phase
	1Ph2W phase rotation	CW /CCW	CW
	Generator voltage measuring	3Ph 4W / 3Ph 3W / 1Ph 2W / 1Ph 3W	3Ph 4W
	Generator current measuring	L1 L2 L3 / Phase L1 / Phase L2 / Phase L3	L1 L2 L3
	Mains voltage measuring	3Ph 4W / 3Ph 3W / 1Ph 2W / 1Ph 3W	3Ph 4W
	Mains current input	Mains current / Ground current / Off	Mains current
	Mains current measuring	Phase L1 / Phase L2 / Phase L3	Phase L1

Table 3-7: Measurement - standard values - configure measurement



NOTE

If the easYgen is intended to be operated in parallel with the mains, the mains voltage measuring inputs must be connected. If an external mains decoupling is performed, jumpers between busbar and mains voltage measuring inputs may be installed.

DE	Generator type			
	{0}	{1o}	{1oc}	{2oc}
CL2	✓	✓	✓	✓
235				

Generator type	Synchron / Asynchron
----------------	----------------------

The easYgen supports two types of generators:

- synchron generators
- asynchron generators (induction generators)

Synchron: The unit provides all functions which are needed for synchron generator applications. Isolated and mains parallel operation is supported.

Asynchron: The unit provides the special function of the asynchronos generator with:

- The speed is regulated with the speed signal from the MPU or J1939/CAN input (as long as the GCB is open).
- The closing of the GCB is executed, if the speed is within the corresponding frequency range of the generator operating window. The voltage and phase angle is ignored in this case.
- The generator monitoring (under/over frequency and under/overvoltage) is switched off, until the generator breaker is closed.
- After opening the GCB, under/over frequency and under/overvoltage monitoring is switched off again.
- The Frequency/MPU speed plausibility monitoring is only active, if the GCB is closed.
- The synchronoscope is not displayed in the asynchron modus.

The asynchron modus is normally used in mains parallel operation. Please consider the following settings:

- Application mode (3401) = GCB/MCB
- MCB control (5733) = Off
- Mains decoupling (3110) = GCB
- Emergency run (2802) = Off
- MPU input (1600) = On
- Generator operating frequency (5802, 5803)



Figure 3-2: Configure measurement - generator type selection



NOTE

The asynchron mode is not recommended for emergency power applications.

EN	System rated frequency			
DE	Nennfrequenz im System			
CL2	{0}	{1o}	{1oc}	{2oc}
1750	✓	✓	✓	✓

System rated frequency **50 / 60 Hz**

The rated frequency of the system is used as a reference figure for all frequency related functions, which use a percentage value, like frequency monitoring, breaker operation windows or the Analog Manager.

EN	Engine rated speed			
DE	Nenn Drehzahl			
CL2	{0}	{1o}	{1oc}	{2oc}
1601	✓	✓	✓	✓

Engine rated speed **500 to 4,000 RPM**

Number of revolutions per minute of the engine at rated engine speed. The speed control with an ECU via J1939 CAN bus refers to this value.

		Generator rated voltage			
EN		{0}	{1o}	{1oc}	{2oc}
DE	CL2	✓	✓	✓	✓
	1766				

Generator rated voltage **50 to 650000 V**

ⓘ This value refers to the rated voltage of the generator (generator voltage on data plate) and is the voltage measured on the potential transformer primary.

The generator potential transformer primary voltage is entered in this parameter. The generator rated voltage is used as a reference figure for all generator voltage related functions, which use a percentage value, like generator voltage monitoring, breaker operation windows or the Analog Manager.

		Mains rated voltage			
EN		{0}	{1o}	{1oc}	{2oc}
DE	CL2	---	---	---	✓
	1768				

Mains rated voltage **50 to 650000 V**

ⓘ This value refers to the rated voltage of the mains and is the voltage measured on the potential transformer primary.

The mains potential transformer primary voltage is entered in this parameter. The mains rated voltage is used as a reference figure for all mains voltage related functions, which use a percentage value, like mains voltage monitoring, breaker operation windows or the Analog Manager.

		Busbar 1 rated voltage			
EN		{0}	{1o}	{1oc}	{2oc}
DE	CL2	✓	✓	✓	✓
	1781				

Busbar 1 rated voltage **50 to 650000 V**

ⓘ This value refers to the rated voltage of busbar 1 and is the voltage measured on the potential transformer primary.
 ⓘ If voltage measuring is configured to 1Ph 3W, the WYE voltage (V_{LIN}) must be entered here.

The busbar 1 potential transformer primary voltage is entered in this parameter. The busbar rated voltage is used as a reference figure for all busbar voltage related functions, which use a percentage value, like synchronization.

		Gen. rated active power [kW]			
EN		{0}	{1o}	{1oc}	{2oc}
DE	CL2	✓	✓	✓	✓
	1752				

Generator rated active power **0.5 to 99999.9 kW**

This value specifies the generator real power rating, which is used as a reference figure for related functions. The generator rated active power is the generator apparent power multiplied by the generator power factor (typically ~0.8). These values are indicated in the generator data plate. Refer to Figure 3-3 for more information.

		Gen. rated react. power [kvar]			
EN		{0}	{1o}	{1oc}	{2oc}
DE	CL2	✓	✓	✓	✓
	1758				

Generator rated reactive power **0.5 to 99999.9 kvar**

This value specifies the generator reactive power rating, which is used as a reference figure for related functions. The generator rated reactive power also depends on the generator values. Refer to Figure 3-3 for more information.

		Generator rated current			
EN		{0}	{1o}	{1oc}	{2oc}
DE	CL2	✓	✓	✓	✓
	1754				

Generator rated current **1 to 32000 A**

This value specifies the generator rated current, which is used as a reference figure for related functions.

		Mains rated active power [kW]			
EN		{0}	{1o}	{1oc}	{2oc}
DE	CL2	✓	✓	✓	✓
	1748				

Mains rated active power **0.5 to 99999.9 kW**

This value specifies the mains real power rating, which is used as a reference figure for related functions. The mains rated active power is a reference value used by several monitoring and control functions. Refer to Figure 3-3 for more information.

EN	Mains rated react. pwr. [kvar]	Mains rated reactive power	0.5 to 99999.9 kvar
DE	Nennblindleistung Netz [kvar]		
CL2 1746	{0} {1o} {1oc} {2oc}	This value specifies the mains reactive power rating, which is used as a reference figure for related functions. The mains rated reactive power is a reference value used by several monitoring and control functions. Refer to Figure 3-3 for more information.	
	✓ ✓ ✓ ✓		
EN	Mains rated current	Mains rated current	5 to 32000 A
DE	Nennstrom Netz		
CL2 1785	{0} {1o} {1oc} {2oc}	This value specifies the mains rated current, which is used as a reference figure for related functions.	
	✓ ✓ ✓ ✓		

Figure 3-3 shows the AC power triangle to illustrate the dependencies between active power, apparent power, reactive power, and power factor.

PF = Power Factor
 P = Active Power = [kW]
 S = Apparent power [kVA]
 Q = Reactive Power [kvar]

$$PF = \frac{P}{S} = \cos \varphi$$

$$Q = \sqrt{S^2 - P^2}$$

$$S = \sqrt{P^2 + Q^2}$$

$$P = S * PF$$

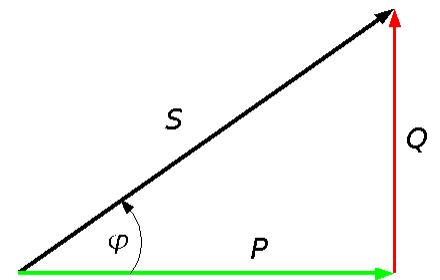

Figure 3-3: AC power triangle

EN	1Ph2W voltage measuring	Measurement principle: 1Ph 2W measuring	Phase - phase / Phase - neutral
DE	Art der 1Ph2W Messung		
CL3 1858	{0} {1o} {1oc} {2oc}	<p>ⓘ Please refer to the comments on measuring principles in the installation manual (37426).</p>	
	✓ ✓ ✓ ✓		
		<p>Phase - phase The unit is configured for measuring phase-phase voltages if 1Ph 2W measuring is selected.</p> <p>Phase - neutral The unit is configured for measuring phase-neutral voltages if 1Ph 2W measuring is selected.</p>	



NOTE

Do never configure the busbar measurement for phase-neutral, if the other systems like mains and generator are configured as 3Ph 3W or 4Ph 4W. The phase angle for synchronisation would be not correct.

EN	1Ph2W phase rotation	Measurement principle: 1Ph 2W phase rotation	CW / CCW
DE	Art der 1Ph2W Drehrichtung		
CL3 1859	{0} {1o} {1oc} {2oc}	<p>ⓘ Please refer to the comments on measuring principles in the installation manual (37426).</p>	
	✓ ✓ ✓ ✓		
		<p>CW..... A clockwise rotation field is considered for 1Ph 2W measuring .</p> <p>CCW..... A counter-clockwise rotation field is considered for 1Ph 2W measuring.</p>	

	Generator voltage measuring			
DE	Gen.Spannungsmessung			
EN	{0}	{1o}	{1oc}	{2oc}
CL2	✓	✓	✓	✓
1851				

Measurement principle: Generator

3Ph 4W / 3Ph 3W / 1Ph 2W / 1Ph 3W

ⓘ Please refer to the comments on measuring principles in the installation manual (37426).

3Ph 4WMeasurement is performed Line-Neutral (WYE connected system) and Line-Line (Delta connected system). The protection depends on the setting of parameter 1770 on page 49. Phase voltages and the neutral must be connected for proper calculation. Measurement, display and protection are adjusted according to the rules for WYE connected systems. Monitoring refers to the following voltages:

- V_{L12} , V_{L23} , and V_{L31} (parameter 1770 configured to "Phase-phase")
- V_{L1N} , V_{L2N} , and V_{L3N} (parameter 1770 configured to "Phase-neutral")

3Ph 3WMeasurement is performed Line-Line (Delta connected system). Phase voltages must be connected for proper calculation. Measurement, display and protection are adjusted according to the rules for Delta connected systems. Monitoring refers to the following voltages:

- V_{L12} , V_{L23} , V_{L31}

1Ph 2WMeasurement is performed Line-Neutral (WYE connected system) if parameter 1858 is configured to "Phase - neutral" and Line-Line (Delta connected system) if parameter 1858 is configured to "Phase - phase". Measurement, display and protection are adjusted according to the rules for phase-phase systems. Monitoring refers to the following voltages:

- V_{L1N} , V_{L12}

1Ph 3WMeasurement is performed Line-Neutral (WYE connected system) and Line-Line (Delta connected system). The protection depends on the setting of parameter 1770 on page 49. Measurement, display, and protection are adjusted according to the rules for single-phase systems. Monitoring refers to the following voltages:

- V_{L1N} , V_{L3N} (parameter 1770 configured to "Phase-phase")
- V_{L13} (parameter 1770 configured to "Phase-neutral")

NOTE: If this parameter is configured to 1Ph 3W, the generator and mains rated voltages (parameters 1766 and 1768) must be entered as Line-Line (Delta) and the busbar 1 rated voltage (parameter 1781) must be entered as Line-Neutral (WYE).

	Generator current measuring			
DE	Gen.Strommessung			
EN	{0}	{1o}	{1oc}	{2oc}
CL2	✓	✓	✓	✓
1850				

Measurement principle: Generator

L1 L2 L3 / Phase L1 / Phase L2 / Phase L3

ⓘ Please refer to the comments on measuring principles in the installation manual (37426). This parameter is only effective if generator voltage measuring (parameter 1851) is configured to "3Ph 4W" or "3Ph 3W".

L1 L2 L3All three phases are monitored. Measurement, display and protection are adjusted according to the rules for 3-phase measurement. Monitoring refers to the following currents:

- I_{L1} , I_{L2} , I_{L3}

Phase L{1/2/3} Only one phase is monitored. Measurement, display and protection are adjusted according to the rules for single-phase measurement. Monitoring refers to the selected phase.

EN	Mains voltage measuring			
DE	Netzspannungsmessung			
CL2	{0}	{1o}	{1oc}	{2oc}
1853	---	---	---	✓

Measurement principle: Mains

3Ph 4W / 3Ph 3W / 1Ph 2W / 1Ph 3W

① Please refer to the comments on measuring principles in the installation manual (37426).

3Ph 4W Measurement is performed Line-Neutral (WYE connected system) and Line-Line (Delta connected system). The protection depends on the setting of parameter 1771 on page 85. Phase voltages and the neutral must be connected for proper calculation. Measurement, display and protection are adjusted according to the rules for WYE connected systems. Monitoring refers to the following voltages:

- V_{L12} , V_{L23} , and V_{L31} (parameter 1771 configured to "Phase-phase")
- V_{L1N} , V_{L2N} and V_{L3N} (parameter 1771 configured to "Phase-neutral")

3Ph 3W Measurement is performed Line-Line (Delta connected system). Phase voltages must be connected for proper calculation. Measurement, display and protection are adjusted according to the rules for Delta connected systems. Monitoring refers to the following voltages:

- V_{L12} , V_{L23} , V_{L31}

1Ph 2W Measurement is performed Line-Neutral (WYE connected system) if parameter 1858 is configured to "Phase - neutral" and Line-Line (Delta connected system) if parameter 1858 is configured to "Phase - phase". Measurement, display and protection are adjusted according to the rules for phase-phase systems. Monitoring refers to the following voltages:

- V_{L1N} , V_{L12}

1Ph 3W Measurement is performed Line-Neutral (WYE connected system) and Line-Line (Delta connected system). The protection depends on the setting of parameter 1771 on page 85. Measurement, display, and protection are adjusted according to the rules for single-phase systems. Monitoring refers to the following voltages:

- V_{L1N} , V_{L3N} (parameter 1771 configured to "Phase-phase")
- V_{L13} (parameter 1771 configured to "Phase-neutral")

NOTE: If this parameter is configured to 1Ph 3W, the generator and mains rated voltages (parameters 1766 and 1768) must be entered as Line-Line (Delta) and the busbar 1 rated voltage (parameter 1781) must be entered as Line-Neutral (WYE).

EN	Mains current input			
DE	Eingang Netzstrom			
CL2				
1854				

Measurement principle: Mains current input

Off / Mains current / Ground current

This parameter configures whether ground or mains current is measured on terminals 1/2 or the input is disabled.

EN	Mains current measuring			
DE	Netzstrommessung			
CL2	{0}	{1o}	{1oc}	{2oc}
1852	---	---	---	✓

Measurement principle: Mains

Phase L1 / Phase L2 / Phase L3

① Please refer to the comments on measuring principles in the installation manual (37426). This parameter is only effective if mains voltage measuring (parameter 1853) is configured to "3Ph 4W" or "3Ph 3W".

Phase L{1/2/3} Measurement is performed for the selected phase only. The measurement and display refer to the selected phase. The configured phase CT must be connected to perform current measurement.

Configure Measurement: Configure Transformer

Parameter Table

Level	Text	Setting range	Default value
Configure transformer			
	Gen. PT primary rated voltage	50 to 650000 V	400 V
	Gen. PT secondary rated volt.	50 to 480 V	400 V
	Gen. CT primary rated current	1 to 32000 A	500 A
	Busb1 PT primary rated voltage	50 to 650000 V	400 V
	Busb1 PT secondary rated volt.	50 to 650000 V	400 V
	Mains PT primary rated voltage	50 to 650000 V	400 V
	Mains PT secondary rated volt.	50 to 480 V	400 V
	Mains CT primary rated current	1 to 32000 A	500 A
	Gnd. CT primary rated current	1 to 32000 A	500 A

Table 3-8: Measurement - standard values - configure transformer

Generator

EN	Gen. PT primary rated voltage			
DE	Gen.Spg.Wandler primär			
CL2	{0}	{1o}	{1oc}	{2oc}
1801	✓	✓	✓	✓

Generator potential transformer primary voltage rating **50 to 650000 V**

Some generator applications may require the use of potential transformers to facilitate measuring the voltages produced by the generator. The rating of the primary side of the potential transformer must be entered into this parameter.

If the generator application does not require potential transformers (i.e. the generated voltage is 480 V or less), then the generated voltage will be entered into this parameter.

EN	Gen. PT secondary rated volt.			
DE	Gen.Spg.Wandler sekundär			
CL2	{0}	{1o}	{1oc}	{2oc}
1800	✓	✓	✓	✓

Generator potential transformer secondary voltage rating **50 to 480 V**

ⓘ The control is equipped with dual voltage measuring inputs. The voltage range of these measurement inputs is dependent upon input terminals are used (see below). This value refers to the secondary voltages of the potential transformers, which are directly connected to the control.

Some generator applications may require the use of potential transformers to facilitate measuring the voltages produced by the generator. The rating of the secondary side of the potential transformer must be entered into this parameter. If the generator application does not require potential transformers (i.e. the generated voltage is 480 V or less), then the generated voltage will be entered into this parameter.

- Rated voltage: 100 Vac (this parameter configured between 50 and 130 V)
- Generator voltage: Terminals 14/16/18/20
- Rated voltage: 400 Vac (this parameter configured between 131 and 480 V)
- Generator voltage: Terminals 15/17/19/21

! WARNING:
Only connect the measured voltage to either the 100 Vac or the 400 Vac inputs. Do not connect both sets of inputs to the measured system.



NOTE

This controller is available in two different hardware version with either 1A [../1] or 5A [../5] current transformer inputs. Both versions are discussed in this manual. The set points for specific parameters will differ depending upon the hardware version, indicated on the data plate.

- [1] easYgen-2xxx-1 = Current transformer with ../1 A rated current
- [5] easYgen-2xxx-5 = Current transformer with ../5 A rated current

EN	Gen. CT primary rated current			
DE	Generator Stromwandler			
CL2	{0}	{1o}	{1oc}	{2oc}
1806	✓	✓	✓	✓

Generator current transformer primary rating

1 to 32000/5 A

ⓘ This screen only applies to controls equipped with 5 A CT inputs. This will not be displayed in the controller screen of a unit equipped with 1 A CT inputs.

The input of the current transformer ratio is necessary for the indication and control of the actual monitored value. The current transformers ratio should be selected so that at least 60% of the secondary current rating can be measured when the monitored system is at 100% of operating capacity (i.e. at 100% of system capacity a 5 A CT should output 3 A). If the current transformers are sized so that the percentage of the output is lower, the loss of resolution may cause inaccuracies in the monitoring and control functions and affect the functionality of the control.

Busbar

EN	Busb1 PT primary rated voltage			
DE	Sams.1 Spg.Wandler primär			
CL2	{0}	{1o}	{1oc}	{2oc}
1813	✓	✓	✓	✓

Busbar 1 potential transformer primary voltage rating **50 to 650000 V**

Some applications may require the use of potential transformers to facilitate measuring the voltages to be monitored. The rating of the primary side of the potential transformer must be entered into this parameter.

If the application does not require potential transformers (i.e. the measured voltage is 480 V or less), then the measured voltage will be entered into this parameter.

EN	Busb1 PT secondary rated volt.			
DE	Sams.1 Spg.Wandler sekundär			
CL2	{0}	{1o}	{1oc}	{2oc}
1812	✓	✓	✓	✓

Busbar 1 potential transformer secondary voltage rating **50 to 480 V**

① The control is equipped with dual voltage measuring inputs. The voltage range of these measurement inputs is dependent upon input terminals are used (see below). This value refers to the secondary voltages of the potential transformers, which are directly connected to the control.

Some applications may require the use of potential transformers to facilitate measuring the busbar voltages. The rating of the secondary side of the potential transformer must be entered into this parameter.

If the application does not require potential transformers (i.e. the measured voltage is 480 V or less), then the measured voltage will be entered into this parameter.

- Rated voltage: 120 Vac (this parameter configured between 50 and 130 V)
 - Busbar voltage: Terminals 22/24/26/28
- Rated voltage: 480 Vac (this parameter configured between 131 and 480 V)
 - Busbar voltage: Terminals 23/25/27/29

! WARNING:
Only connect the measured voltage to either the 100 Vac or the 400 Vac inputs. Do not connect both sets of inputs to the measured system.

Mains PT

EN	Mains PT primary rated voltage				
DE	Netz.Spg.Wandler primär				
CL2	{0}	{1o}	{1oc}	{2oc}	
1804	---	---	---	✓	

Mains potential transformer primary voltage rating

50 to 650000 V

Some applications may require the use of potential transformers to facilitate measuring the voltages to be monitored. The rating of the primary side of the potential transformer must be entered into this parameter.

If the application does not require potential transformers (i.e. the measured voltage is 480 V or less), then the measured voltage will be entered into this parameter.

EN	Mains PT secondary rated volt.				
DE	Netz.Spg.Wandler sekundär				
CL2	{0}	{1o}	{1oc}	{2oc}	
1803	---	---	---	✓	

Mains potential transformer secondary voltage rating

50 to 480 V

① The control is equipped with dual voltage measuring inputs. The voltage range of these measurement inputs is dependent upon input terminals are used (see below). This value refers to the secondary voltages of the potential transformers, which are directly connected to the control.

Some applications may require the use of potential transformers to facilitate measuring the mains voltages. The rating of the secondary side of the potential transformer must be entered into this parameter.

If the application does not require potential transformers (i.e. the measured voltage is 480 V or less), then the measured voltage will be entered into this parameter.

- Rated voltage: 120 Vac (this parameter configured between 50 and 130 V)
- Mains voltage: Terminals 22/24/26/28
- Rated voltage: 480 Vac (this parameter configured between 131 and 480 V)
- Mains Voltage: Terminals 23/25/27/29

! WARNING:

Only connect the measured voltage to either the 100 Vac or the 400 Vac inputs. Do not connect both sets of inputs to the measured system.

Mains Current Transformer

EN	Mains CT primary rated current				
DE	Netz Stromwandler				
CL2	{0}	{1o}	{1oc}	{2oc}	
1806	---	---	---	☑	
1807					

Mains current transformer primary rating

1 to 32000/x A

This screen is only visible if parameter 1854 is configured as Mains. The input of the current transformer ratio is necessary for the indication and control of the actual monitored value. The current transformers ratio should be selected so that at least 60% of the secondary current rating can be measured when the monitored system is at 100% of operating capacity (i.e. at 100% of system capacity a 5 A CT should output 3 A). If the current transformers are sized so that the percentage of the output is lower, the loss of resolution may cause inaccuracies in the monitoring and control functions and affect the functionality of the control.

Ground Current Transformer

EN	Gnd. CT primary rated current			
DE	Erd-Stromwandler			
CL2	{0}	{10}	{10c}	{20c}
1810	✓	✓	✓	<input checked="" type="checkbox"/>

Ground current transformer primary rating

1 to 32000/5 A

ⓘ This screen only applies to controls equipped with 5 A CT inputs. This will not be displayed in the controller screen of a unit equipped with 1 A CT inputs.

This screen is only visible if parameter 1854 is configured as Ground. The current transformers ratio should be selected so that at least 60% of the secondary current rating can be measured when the monitored system is at 100% of operating capacity (i.e. at 100% of system capacity a 5 A CT should output 3 A). If the current transformers are sized so that the percentage of the output is lower, the loss of resolution may cause inaccuracies in the monitoring and control functions and affect the functionality of the control.

Configure Monitoring



Configure Monitoring: Generator

Parameter Table

Level	Text	Setting range	Default value
Configure generator monitoring			
	Generator voltage monitoring	Phase - phase / Phase - neutral	Phase - phase

Table 3-9: Monitoring - standard values - configure generator monitoring

EN	Generator voltage monitoring				
DE	Gen. Spannungsüberwachung				
CL2	{0}	{1o}	{1oc}	{2oc}	
1770	✓	✓	✓	✓	

Generator protection: type of monitoring

Phase - phase / Phase - neutral

The unit can either monitor the phase-neutral (wye) voltages or the phase-phase (delta) voltages. If the controller is used in a compensated or isolated network, voltage protection monitoring should be configured as phase-neutral to prevent earth-faults resulting in tripping of the voltage protections.

! WARNING:
This parameter defines how the protective functions operate.

Phase - phase The phase-phase voltage will be measured and all subsequent parameters concerning voltage monitoring "generator" are referred to this value (V_{L-L}).

Phase - neutral The phase-neutral voltage will be measured and all subsequent parameters concerning voltage monitoring "generator" are referred to this value (V_{L-N}).

Configure Monitoring: Generator, Operating Voltage / Frequency

Parameter Table

Level	Text	Setting range	Default value
Configure generator operating voltage / frequency			
	Upper voltage limit	100 to 150 %	110 %
	Lower voltage limit	50 to 100 %	90 %
	Upper frequency limit	100.0 to 150.0 %	110 %
	Lower frequency limit	50.0 to 100.0 %	90 %

Table 3-10: Monitoring - standard values - configure generator operating voltage / frequency

EN	Upper voltage limit			
DE	Obere Spannungsabw.			
CL2	{0}	{1o}	{1oc}	{2oc}
5800	✓	✓	✓	✓

Generator maximum operating voltage limit **100 to 150 %**

The maximum permissible positive deviation of the generator voltage from the generator rated voltage (parameter 1766 on page 40) is configured here. This value may be used as a voltage limit switch. The conditional state of this switch may be used as a command variable for the *LogicsManager* (02.03).

EN	Lower voltage limit			
DE	Untere Spannungsabw.			
CL2	{0}	{1o}	{1oc}	{2oc}
5801	✓	✓	✓	✓

Generator minimum operating voltage limit **50 to 100 %**

The maximum permissible negative deviation of the generator voltage from the generator rated voltage (parameter 1766 on page 40) is configured here. This value may be used as a voltage limit switch. The conditional state of this switch may be used as a command variable for the *LogicsManager* (02.03).

EN	Upper frequency limit			
DE	Obere Frequenzabw.			
CL2	{0}	{1o}	{1oc}	{2oc}
5802	✓	✓	✓	✓

Generator maximum operating frequency limit **100.0 to 150.0 %**

The maximum permissible positive deviation of the generator frequency from the rated system frequency (parameter 1750 on page 39) is configured here. This value may be used as a frequency limit switch. The conditional state of this switch may be used as a command variable for the *LogicsManager* (02.04).

EN	Lower frequency limit			
DE	Untere Frequenzabw.			
CL2	{0}	{1o}	{1oc}	{2oc}
5803	✓	✓	✓	✓

Generator minimum operating frequency limit **50.0 to 100.0 %**

The maximum permissible negative deviation of the generator frequency from the rated system frequency (parameter 1750 on page 39) is configured here. This value may be used as a frequency limit switch. The conditional state of this switch may be used as a command variable for the *LogicsManager* (02.04).



NOTE

The operating voltage/frequency parameters are used to check if the values are in range when performing a dead bus closure and synchronization of the generator. Busbar must be within this ranges to synchronize the generator to the busbar.

It is recommended to configure the operating limits within the monitoring limits.

Configure Monitoring: Generator, Overfrequency (Levels 1 & 2) ANSI# 810

This controller provides the user with two alarm levels for generator overfrequency. Both alarms are definite time alarms and are illustrated in the figure below. The figure diagrams a frequency trend and the associated pickup times and length of the alarms. Monitoring for overfrequency faults is performed in two steps.

If this protective function is triggered, the display indicates "Gen. overfrequency 1" or "Gen. overfrequency 2" and the logical command variable "06.01" or "06.02" will be enabled.

Refer to Appendix E: Triggering Characteristics, Figure 3-37 on page 324 for the triggering characteristic of this monitoring function.

Parameter table

The parameter limits represented in this table have identical permissible ranges. Each parameter may be configured with different settings to create unique trip characteristics for specific thresholds.

Level	Text	Setting range	Default value
Overfrequency (the hysteresis is 0.05 Hz.)			
Level 1	Monitoring	On / Off	On
	Limit	50.0 to 130.0 %	110.0 %
	Delay	0.02 to 99.99 s	1.50 s
	Alarm class	A/B/C/D/E/F	B
	Self acknowledgment	Yes / No	No
Level 2	Delayed by engine speed	Yes / No	No
	Monitoring	On / Off	On
	Limit	50.0 to 130.0 %	115.0 %
	Delay	0.02 to 99.99 s	0.30 s
	Alarm class	A/B/C/D/E/F	F
	Self acknowledgment	Yes / No	No
	Delayed by engine speed	Yes / No	No

Table 3-11: Monitoring - standard values - generator overfrequency

EN	Monitoring				
DE	Überwachung				
CL2	{0}	{1o}	{1oc}	{2oc}	
1900	✓	✓	✓	✓	
1906					

Gen.Overfrequency: Monitoring (Level 1/Level 2) On / Off

On..... Overfrequency monitoring is carried out according to the following parameters. Monitoring is performed at two levels. Both values may be configured independent from each other (prerequisite: Level 1 limit < limit 2).

Off Monitoring is disabled for Level 1 limit and/or Level 2 limit.

EN	Limit				
DE	Grenzwert				
CL2	{0}	{1o}	{1oc}	{2oc}	
1904	✓	✓	✓	✓	
1910					

Gen.Overfrequency: Threshold value (Level 1/Level 2) 50.0 to 130.0 %

ⓘ This value refers to the System rated frequency (parameter 1750 on page 39).

The percentage values that are to be monitored for each threshold limit are defined here. If this value is reached or exceeded for at least the delay time without interruption, the action specified by the alarm class is initiated.

EN	Delay				
DE	Verzögerung				
CL2	{0}	{1o}	{1oc}	{2oc}	
1905	✓	✓	✓	✓	
1911					

Gen.Overfrequency: Delay (Level 1/Level 2) 0.02 to 99.99 s

If the monitored generator frequency value exceeds the threshold value for the delay time configured here, an alarm will be issued. If the monitored generator frequency falls below the threshold (minus the hysteresis) before the delay expires the time will be reset.

EN	Alarm class				
DE	Alarmklasse				
CL2	{0}	{1o}	{1oc}	{2oc}	
1901	✓	✓	✓	✓	
1907					

Gen.Overfrequency: Alarm class (Level 1/Level 2) Class A/B/C/D/E/F

ⓘ See chapter "Alarm" on page 271.

Each limit may be assigned an independent alarm class that specifies what action should be taken when the limit is surpassed.

DE	EN	Self acknowledge			
		Selbstquittierend			
CL2		{0}	{1o}	{1oc}	{2oc}
1902		✓	✓	✓	✓
1908					

Gen. overfrequency: Self acknowledgment (Level 1/Level 2) Yes / No

Yes.....The control automatically clears the alarm if the fault condition is no longer detected.

NoThe control does not automatically reset the alarm when the fault condition is no longer detected. The alarm must be acknowledged and reset by manually pressing the appropriate buttons or by activating the *LogicsManager* output "External acknowledgement" (via a discrete input or via an interface).

DE	EN	Delayed by engine speed			
		Verzögert durch Motordrehzahl			
CL2		{0}	{1o}	{1oc}	{2oc}
1903		✓	✓	✓	✓
1909					

Gen. overfrequency Engine delayed monitoring (Level 1/Level 2) Yes / No

Yes.....Monitoring for fault conditions is not performed until engine delayed monitoring is enabled. The engine monitoring delay time (parameter 3315 on page 186) must expire prior to fault monitoring being enabled for parameters assigned this delay.

NoMonitoring for this fault condition is continuously enabled regardless of engine speed.

Configure Monitoring: Generator, Underfrequency (Levels 1 & 2) ANSI# 81U

This controller provides the user with two alarm levels for generator underfrequency. Both alarms are definite time alarms and are illustrated in the figure below. The figure diagrams a frequency trend and the associated pickup times and length of the alarms. Monitoring for underfrequency faults is performed in two steps. If this protective function is triggered, the display indicates "Gen. underfrequency 1" or "Gen. underfrequency 2" and the logical command variable "06.03" or "06.04" will be enabled.

Refer to Appendix E: Triggering Characteristics, Figure 3-38 on page 325 for the triggering characteristic of this monitoring function.

Parameter table

The parameter limits represented in this table have identical permissible ranges. Each parameter may be configured with different settings to create unique trip characteristics for specific thresholds.

Level	Text	Setting range	Default value
Underfrequency (the hysteresis is 0.05 Hz.)			
Level 1	Monitoring	On / Off	On
	Limit	50.0 to 130.0 %	90.0 %
	Delay	0.02 to 99.99 s	5.00 s
	Alarm class	A/B/C/D/E/F	B
	Self acknowledgment	Yes / No	No
	Delayed by engine speed	Yes / No	Yes
Level 2	Monitoring	On / Off	On
	Limit	50.0 to 130.0 %	84.0 %
	Delay	0.02 to 99.99 s	0.30 s
	Alarm class	A/B/C/D/E/F	F
	Self acknowledgment	Yes / No	No
	Delayed by engine speed	Yes / No	Yes

Table 3-12: Monitoring - standard values - generator underfrequency

EN	Monitoring				
DE	Überwachung				
CL2	{0}	{1o}	{1oc}	{2oc}	
1950	✓	✓	✓	✓	
1956					

Gen. underfrequency: Monitoring (Level 1/Level 2) On / Off

On..... Underfrequency monitoring is carried out according to the following parameters. Monitoring is performed at two levels. Both values may be configured independent from each other (prerequisite: Level 1 > Level 2).

Off Monitoring is disabled for Level 1 limit and/or Level 2 limit.

EN	Limit				
DE	Grenzwert				
CL2	{0}	{1o}	{1oc}	{2oc}	
1954	✓	✓	✓	✓	
1960					

Gen. underfrequency: Threshold value (Level 1/Level 2) 50.0 to 130.0 %

ⓘ This value refers to the System rated frequency (parameter 1750 on page 39).

The percentage values that are to be monitored for each threshold limit are defined here. If this value is reached or fallen below for at least the delay time without interruption, the action specified by the alarm class is initiated.

EN	Delay				
DE	Verzögerung				
CL2	{0}	{1o}	{1oc}	{2oc}	
1955	✓	✓	✓	✓	
1961					

Gen. underfrequency: Delay (Level 1/Level 2) 0.02 to 99.99 s

If the monitored generator frequency value falls below the threshold value for the delay time configured here, an alarm will be issued. If the monitored generator frequency exceeds the threshold (plus the hysteresis) again before the delay expires the time will be reset.

EN	Alarm class				
DE	Alarmklasse				
CL2	{0}	{1o}	{1oc}	{2oc}	
1951	✓	✓	✓	✓	
1957					

Gen. underfrequency: Alarm class (Level 1/Level 2) Class A/B/C/D/E/F

ⓘ See chapter "Alarm" on page 271.

Each limit may be assigned an independent alarm class that specifies what action should be taken when the limit is surpassed.

DE	EN	Self acknowledge			
DE	EN	Selbstquittierend			
CL2		{0}	{1o}	{1oc}	{2oc}
1952		✓	✓	✓	✓
1958					

Gen. underfrequency: Self acknowledgment (Level 1/Level 2) Yes / No

Yes..... The control automatically clears the alarm if the fault condition is no longer detected.

No..... The control does not automatically reset the alarm when the fault condition is no longer detected. The alarm must be acknowledged and reset by manually pressing the appropriate buttons or by activating the *LogicsManager* output "External acknowledgement" (via a discrete input or via an interface).

DE	EN	Delayed by engine speed			
DE	EN	Verzögert durch Motordrehzahl			
CL2		{0}	{1o}	{1oc}	{2oc}
1953		✓	✓	✓	✓
1959					

Gen. underfrequency Engine delayed monitoring (Limit 1/Limit 2) Yes / No

Yes..... Monitoring for fault conditions is not performed until engine delayed monitoring is enabled. The engine monitoring delay time (parameter 3315 on page 186) must expire prior to fault monitoring being enabled for parameters assigned this delay.

No..... Monitoring for this fault condition is continuously enabled regardless of engine speed.



NOTE

This monitoring function is disabled when the idle mode (see page 189) is active.

Configure Monitoring: Generator, Overvoltage (Levels 1 & 2) ANSI# 59

Voltage is monitored according to how the parameter "Generator voltage measuring" (parameter 1851 on page 42) is configured. This controller provides the user with two alarm levels for generator overvoltage. Both alarms are definite time alarms and are illustrated in the figure below. The figure diagrams a frequency trend and the associated pickup times and length of the alarms. Monitoring for overvoltage faults is performed in two steps. If this protective function is triggered, the display indicates "Gen. overvoltage 1" or "Gen. overvoltage 2" and the logical command variable "06.05" or "06.06" will be enabled.

Refer to Appendix E: Triggering Characteristics, Figure 3-37 on page 324 for the triggering characteristic of this monitoring function.

Parameter table

The parameter limits represented in this table have identical permissible ranges. Each parameter may be configured with different settings to create unique trip characteristics for specific thresholds.

Level	Text	Setting range	Default value
Overvoltage (the hysteresis is 0.7 % of the rated value)			
Level 1	Monitoring	On / Off	On
	Limit	50.0 to 125.0 %	108.0 %
	Delay	0.02 to 99.99 s	5.00 s
	Alarm class	A/B/C/D/E/F	B
	Self acknowledgment	Yes / No	No
Level 2	Monitoring	On / Off	On
	Limit	50.0 to 125.0 %	112.0 %
	Delay	0.02 to 99.99 s	0.30 s
	Alarm class	A/B/C/D/E/F	F
	Self acknowledgment	Yes / No	No
	Delayed by engine speed	Yes / No	No

Table 3-13: Monitoring - standard values - generator overvoltage

EN	Monitoring				
DE	Überwachung				
CL2	{0}	{1o}	{1oc}	{2oc}	
2000	✓	✓	✓	✓	
2006					

Gen. overvoltage: Monitoring (Level 1/Level 2) On / Off

On Overvoltage monitoring is carried out according to the following parameters. Monitoring is performed at two levels. Both values may be configured independent from each other (prerequisite: Level 1 limit < Level 2 limit).

Off Monitoring is disabled for Level 1 limit and/or Level 2 limit.

EN	Limit				
DE	Grenzwert				
CL2	{0}	{1o}	{1oc}	{2oc}	
2004	✓	✓	✓	✓	
2010					

Gen. overvoltage: Threshold value (Level 1/Level 2) 50.0 to 125.0 %

ⓘ This value refers to the Generator rated voltage (parameter 1766 on page 40).

The percentage values that are to be monitored for each threshold limit are defined here. If this value is reached or exceeded for at least the delay time without interruption, the action specified by the alarm class is initiated.

EN	Delay				
DE	Verzögerung				
CL2	{0}	{1o}	{1oc}	{2oc}	
2005	✓	✓	✓	✓	
2011					

Gen. overvoltage: Delay (Level 1/Level 2) 0.02 to 99.99 s

If the monitored generator voltage exceeds the threshold value for the delay time configured here, an alarm will be issued. If the monitored generator voltage falls below the threshold (minus the hysteresis) before the delay expires the time will be reset.

EN	Alarm class				
DE	Alarmklasse				
CL2	{0}	{1o}	{1oc}	{2oc}	
2001	✓	✓	✓	✓	
2007					

Gen. overvoltage: Alarm class (Level 1/Level 2) Class A/B/C/D/E/F

ⓘ See chapter "Alarm" on page 271.

Each limit may be assigned an independent alarm class that specifies what action should be taken when the limit is surpassed.

DE	EN	Self acknowledge			
CL2		{0}	{1o}	{1oc}	{2oc}
2002		✓	✓	✓	✓
2008					

Gen. overvoltage: Self acknowledgment (Level 1/Level 2) Yes / No

Yes.....The control automatically clears the alarm if the fault condition is no longer detected.

NoThe control does not automatically reset the alarm when the fault condition is no longer detected. The alarm must be acknowledged and reset by manually pressing the appropriate buttons or by activating the *LogicsManager* output "External acknowledgement" (via a discrete input or via an interface).

DE	EN	Delayed by engine speed			
CL2		{0}	{1o}	{1oc}	{2oc}
2003		✓	✓	✓	✓
2009					

Gen. overvoltage: Engine delayed monitoring (Level 1/Level 2) Yes / No

Yes.....Monitoring for fault conditions is not performed until engine delayed monitoring is enabled. The engine monitoring delay time (parameter 3315 on page 186) must expire prior to fault monitoring being enabled for parameters assigned this delay.

NoMonitoring for this fault condition is continuously enabled regardless of engine speed.

Configure Monitoring: Generator, Undervoltage (Levels 1 & 2) ANSI# 27

Voltage is monitored according to how the parameter "Generator voltage measuring" (parameter 1851 on page 42) is configured. This controller provides the user with two alarm levels for generator overvoltage. Both alarms are definite time alarms and are illustrated in the figure below. The figure diagrams a frequency trend and the associated pickup times and length of the alarms. Monitoring for undervoltage faults is performed in two steps.

If this protective function is triggered, the display indicates "Gen. undervoltage 1" or "Gen. undervoltage 2" and the logical command variable "06.07" or "06.08" will be enabled.

Refer to Appendix E: Triggering Characteristics, Figure 3-38 on page 325 for the triggering characteristic of this monitoring function.

Parameter table

The parameter limits represented in this table have identical permissible ranges. Each parameter may be configured with different settings to create unique trip characteristics for specific thresholds.

Level	Text	Setting range	Default value
Undervoltage (the hysteresis is 0.7 % of the rated value)			
Level 1	Monitoring	On / Off	On
	Limit	50.0 to 125.0 %	92.0 %
	Delay	0.02 to 99.99 s	5.00 s
	Alarm class	A/B/C/D/E/F	B
	Self acknowledgment	Yes / No	No
	Delayed by engine speed	Yes / No	Yes
Level 2	Monitoring	On / Off	On
	Limit	50.0 to 125.0 %	88.0 %
	Delay	0.02 to 99.99 s	00.30 s
	Alarm class	A/B/C/D/E/F	F
	Self acknowledgment	Yes / No	No
	Delayed by engine speed	Yes / No	Yes

Table 3-14: Monitoring - standard values - generator undervoltage

EN	Monitoring				
DE	Überwachung				
CL2	{0}	{1o}	{1oc}	{2oc}	
2050	✓	✓	✓	✓	
2056					

Gen. undervoltage: Monitoring (Level 1/Level 2) On / Off

On Undervoltage monitoring is carried out according to the following parameters. Monitoring is performed at two levels. Both values may be configured independent from each other (prerequisite: Level 1 limit < Level 2 limit).
Off..... Monitoring is disabled for Level 1 limit and/or Level 2 limit.

EN	Limit				
DE	Grenzwert				
CL2	{0}	{1o}	{1oc}	{2oc}	
2054	✓	✓	✓	✓	
2060					

Gen. undervoltage: Threshold value (Level 1/Level 2) 50.0 to 125.0 %

① This value refers to the Generator rated voltage (parameter 1766 on page 40).

The percentage values that are to be monitored for each threshold limit are defined here. If this value is reached or fallen below for at least the delay time without interruption, the action specified by the alarm class is initiated.

EN	Delay				
DE	Verzögerung				
CL2	{0}	{1o}	{1oc}	{2oc}	
2055	✓	✓	✓	✓	
2061					

Gen. undervoltage: Delay (Level 1/Level 2) 0.02 to 99.99 s

If the monitored generator voltage falls below the threshold value for the delay time configured here, an alarm will be issued. If the monitored generator voltage exceeds the threshold (plus the hysteresis) again before the delay expires the time will be reset.

		Alarm class			
DE	EN	Alarmklasse			
CL2		{0}	{1o}	{1oc}	{2oc}
2051		✓	✓	✓	✓
2057					

Gen. undervoltage: Alarm class (Level 1/Level 2) Class A/B/C/D/E/F

See chapter "Alarm" on page 271.

Each limit may be assigned an independent alarm class that specifies what action should be taken when the limit is surpassed.

		Self acknowledge			
DE	EN	Selbstquittierend			
CL2		{0}	{1o}	{1oc}	{2oc}
2052		✓	✓	✓	✓
2058					

Gen. undervoltage: Self acknowledgment (Level 1/Level 2) Yes / No

Yes.....The control automatically clears the alarm if the fault condition is no longer detected.

NoThe control does not automatically reset the alarm when the fault condition is no longer detected. The alarm must be acknowledged and reset by manually pressing the appropriate buttons or by activating the *LogicsManager* output "External acknowledgement" (via a discrete input or via an interface).

		Delayed by engine speed			
DE	EN	Verzögert durch Motordrehzahl			
CL2		{0}	{1o}	{1oc}	{2oc}
2053		✓	✓	✓	✓
2059					

Gen. undervoltage: Delayed engine speed (Level 1/Level 2) Yes / No

Yes.....Monitoring for fault conditions is not performed until engine delayed monitoring is enabled. The engine monitoring delay time (parameter 3315 on page 186) must expire prior to fault monitoring being enabled for parameters assigned this delay.

NoMonitoring for this fault condition is continuously enabled regardless of engine speed.



NOTE

This monitoring function is disabled when the idle mode (see page 189) is active.

Configure Monitoring: Generator, Time-Overcurrent Monit. (Levels 1, 2 & 3) ANSI# 50/51

Current is monitored according to how the parameter "Generator current measuring" (parameter 1850 on page 42) is configured. This controller provides the user with three definite time alarm levels for generator overcurrent faults and may be setup as illustrated in the figure below. Monitoring of the maximum phase current is performed in three steps. Every step can be provided with a delay time independent of the other steps.

If this protective function is triggered, the display indicates "Gen. overcurrent 1", "Gen. overcurrent 2", or "Gen. overcurrent 3" and the logical command variable "06.09", "06.10.", or "06.11" will be enabled.

Refer to Appendix E: Triggering Characteristics, Figure 3-36 on page 323 for the triggering characteristic of this monitoring function.

Parameter table

The parameter limits represented in this table have identical permissible ranges. Each parameter may be configured with different settings to create unique trip characteristics for specific thresholds.

Level	Text	Setting range	Default value
Overcurrent (the hysteresis is 1 % of the rated value)			
Level 1	Monitoring	On / Off	On
	Limit	50.0 to 300.0 %	110.0 %
	Delay	0.02 to 99.99 s	30.00 s
	Alarm class	A/B/C/D/E/F	E
	Self acknowledgment	Yes / No	No
Level 2	Monitoring	On / Off	On
	Limit	50.0 to 300.0 %	150.0 %
	Delay	0.02 to 99.99 s	1.00 s
	Alarm class	A/B/C/D/E/F	F
	Self acknowledgment	Yes / No	No
Level 3	Monitoring	On / Off	On
	Limit	50.0 to 300.0 %	250.0 %
	Delay	0.02 to 99.99 s	0.40 s
	Alarm class	A/B/C/D/E/F	F
	Self acknowledgment	Yes / No	No

Table 3-15: Monitoring - standard values - generator time-overcurrent

EN	Monitoring				
DE	Überwachung				
CL2	{0}	{1o}	{1oc}	{2oc}	
2200	✓	✓	✓	✓	
2206					
2212					

Gen. overcurrent, TOC: Monitoring (Level 1/Level 2/Level 3) On / Off

On Overcurrent monitoring is carried out according to the following parameters. Monitoring is performed at three levels. All three values may be configured independent from each other (prerequisite: Level 1 < Level 2 < Level 3).

Off Monitoring is disabled for Level 1 limit, Level 2 limit, and/or Level 3 limit.

EN	Limit				
DE	Grenzwert				
CL2	{0}	{1o}	{1oc}	{2oc}	
2204	✓	✓	✓	✓	
2210					
2216					

Gen. overcurrent, TOC: Threshold value (Level 1/Level 2/Level 3) 50.0 to 300.0 %

ⓘ This value refers to the Generator rated current (parameter 1754 on page 40).

The percentage values that are to be monitored for each threshold limit are defined here. If this value is reached or exceeded for at least the delay time without interruption, the action specified by the alarm class is initiated.

EN	Delay				
DE	Verzögerung				
CL2	{0}	{1o}	{1oc}	{2oc}	
2205	✓	✓	✓	✓	
2211					
2217					

Gen. overcurrent, TOC: Delay (Level 1/Level 2/Level 3) 0.02 to 99.99 s

If the monitored generator current exceeds the threshold value for the delay time configured here, an alarm will be issued. If the monitored generator current falls below the threshold (minus the hysteresis) before the delay expires the time will be reset.

	Alarm class			
DE	Alarmklasse			
CL2	{0}	{1o}	{1oc}	{2oc}
2201	✓	✓	✓	✓
2207				
2213				

Gen. overcurrent, TOC: Alarm class (Level 1/Level 2/Level 3) Class A/B/C/D/E/F

See chapter "Alarm" on page 271.

Each limit may be assigned an independent alarm class that specifies what action should be taken when the limit is surpassed.

	Self acknowledge			
DE	Selbstquittierend			
CL2	{0}	{1o}	{1oc}	{2oc}
2202	✓	✓	✓	✓
2208				
2214				

Gen. overcurrent, TOC: Self acknowledgment (Level 1/Level 2/Level 3) On / Off

Yes.....The control automatically clears the alarm if the fault condition is no longer detected.

NoThe control does not automatically reset the alarm when the fault condition is no longer detected. The alarm must be acknowledged and reset by manually pressing the appropriate buttons or by activating the *LogicsManager* output "External acknowledgement" (via a discrete input or via an interface).

Configure Monitoring: Generator, Reverse/Reduced Power (Levels 1 & 2) ANSI# 32R/F

The power produced by the generator is calculated from the voltage and current values measured in accordance with how parameters "Generator voltage measuring" (parameter 1851 on page 42) and "Generator current measuring" (parameter 1850 on page 42) are configured. The generator power limits may be configured for reduced power and/or reverse power depending on the threshold values entered. The note below explains how a reduced or reverse power limit is configured. If the single-phase or three-phase measured real power is below the configured limit of the reduced load or below the configured value of the reverse power, an alarm will be issued. If this protective function is triggered, the display indicates "Gen. rev./red. pwr.1" or "Gen. rev./red. pwr.2" and the logical command variable "06.12" or "06.13" will be enabled.

Refer to Appendix E: Triggering Characteristics, Figure 3-39 on page 326 for the triggering characteristic of this monitoring function.



NOTE

Definition

- **Reduced power**
Fault initiated if the monitored real power falls below the configured (positive) limit.
- **Reverse power**
Fault initiated if the direction of the monitored real power reverses and the configured (negative) limit is exceeded.

The values for reverse /reduced power monitoring can be configured as follows:

- Level 1 limit = **Positive** and
Level 2 limit = **Positive** (whereas Level 1 limit > Level 2 limit > 0 %):
⇒ **Both limits are configured for reduced power monitoring.**
(example: rated power is 100 kW, Level 1 limit = 5 % > Level 2 limit = 3 %; tripping if real power falls below 5 kW (Level 1 limit) or 3 kW (Level 2 limit))
- Level 1 limit = **Negative** and
Level 2 limit = **Negative** (whereas Level 2 limit < Level 1 limit < 0%):
⇒ **Both limits are configured for reverse power monitoring.**
(example: rated power is 100 kW, Level 1 limit = -3 % > Level 2 limit = -5 %; tripping if real power falls below -3 kW (Level 1 limit) or -5 kW (Level 2 limit))
- Level 1 limit = **Positive** and
Level 2 limit = **Negative** (whereas Level 1 limit > 0 % > Level 2 limit):
⇒ **Level 1 is configured for reduced power monitoring and**
⇒ **Level 2 is configured for reverse power monitoring.**
(example: rated power is 100 kW, Level 1 limit = 3 % > Level 2 limit = -5 %; tripping if real power falls below 3 kW (Level 1 limit) or -5 kW (Level 2 limit))

Parameter table

The parameter limits represented in this table have identical permissible ranges. Each parameter may be configured with different settings to create unique trip characteristics for specific thresholds.

Level	Text	Setting range	Default value
Reverse / reduced power (the hysteresis is 1 % of the rated value)			
Level 1	Monitoring	On / Off	On
	Limit	-99.9 to 99.9 %	-3.0 %
Level 1 > 0 % Red. power	Delay	0.02 to 99.99 s	5.00 s
	Alarm class	A/B/C/D/E/F	B
Level 1 < 0 % Rev. power	Self acknowledgment	Yes / No	No
	Delayed by engine speed	Yes / No	No
Level 2	Monitoring	On / Off	On
	Limit	-99.9 to 99.9 %	-5.0 %
Level 2 > 0 % Red. power	Delay	0.02 to 99.99 s	3.00 s
	Alarm class	A/B/C/D/E/F	E
Level 2 < 0 % Rev. power	Self acknowledgment	Yes / No	No
	Delayed by engine speed	Yes / No	No

Table 3-16: Monitoring - standard values - generator reverse / reduced power

EN		Monitoring			
DE		Überwachung			
CL2	{0} {1o} {1oc} {2oc}	✓	✓	✓	✓
2250					
2256					

Gen. reverse/reduced power: Monitoring (Level 1/Level 2) On / Off

On.....Reverse/reduced power monitoring is carried out according to the following parameters. Both values may be configured independent from each other (prerequisite for {1oc}, {2oc}: GCB must be closed).

Off.....Monitoring is disabled for Level 1 limit and/or Level 2 limit.

EN		Limit			
DE		Grenzwert			
CL2	{0} {1o} {1oc} {2oc}	✓	✓	✓	✓
2254					
2260					

Gen. reverse/reduced power: Threshold value (Level 1/Level 2) -99.9 to 99.9 %

① This value refers to the Generator rated active power (parameter 1752 on page 40).

The percentage values that are to be monitored for each threshold limit are defined here. If this value is reached or fallen below for at least the delay time without interruption, the action specified by the alarm class is initiated.

EN		Delay			
DE		Verzögerung			
CL2	{0} {1o} {1oc} {2oc}	✓	✓	✓	✓
2255					
2261					

Gen. reverse/reduced power: Delay (Level 1/Level 2) 0.02 to 99.99 s

If the monitored generator power falls below the threshold value for the delay time configured here, an alarm will be issued. If the monitored generator power exceeds or falls below the threshold (plus/minus the hysteresis) again before the delay expires the time will be reset.

EN		Alarm class			
DE		Alarmklasse			
CL2	{0} {1o} {1oc} {2oc}	✓	✓	✓	✓
2251					
2257					

Gen. reverse/reduced power: Alarm class (Lim.1/Lim.2) Class A/B/C/D/E/F

① See chapter "Alarm" on page 271.

Each limit may be assigned an independent alarm class that specifies what action should be taken when the limit is surpassed.

EN		Self acknowledge			
DE		Selbstquittierend			
CL2	{0} {1o} {1oc} {2oc}	✓	✓	✓	✓
2252					
2258					

Gen. reverse/reduced power: Self acknowledgment (Level 1/Level 2) Yes / No

Yes.....The control automatically clears the alarm if the fault condition is no longer detected.

No.....The control does not automatically reset the alarm when the fault condition is no longer detected. The alarm must be acknowledged and reset by manually pressing the appropriate buttons or by activating the *LogicsManager* output "External acknowledgement" (via a discrete input or via an interface).

EN		Delayed by engine speed			
DE		Verzögert durch Motordrehzahl			
CL2	{0} {1o} {1oc} {2oc}	✓	✓	✓	✓
2253					
2259					

Gen. reverse/reduced power: Engine delayed monitoring (Level 1/Level 2) Yes / No

Yes.....Monitoring for fault conditions is not performed until engine delayed monitoring is enabled. The engine monitoring delay time (parameter 3315 on page 186) must expire prior to fault monitoring being enabled for parameters assigned this delay.

No.....Monitoring for this fault condition is continuously enabled regardless of engine speed.

Configure Monitoring: Generator, Overload IOP (Levels 1 & 2) ANSI# 32

(IOP = Isolated Operation in Parallel)

The power produced by the generator is calculated from the voltage and current values measured in accordance with how parameters "Generator voltage measuring" (parameter 1851 on page 42) and "Generator current measuring" (parameter 1850 on page 42) are configured. The controller monitors if the system is in a mains parallel or an isolated operation. When the controller detects that the system is operating isolated from the mains, the Generator Overload MOP (refer to page 65) monitoring is disabled. If the measured generator real power during an isolated operation is above the configured limit an alarm will be issued.

If this protective function is triggered, the display indicates "Gen. Overload IOP 1" or "Gen. Overload IOP 2" and the logical command variable "06.14" or "06.15" will be enabled.

Refer to Appendix E: Triggering Characteristics, Figure 3-37 on page 324 for the triggering characteristic of this monitoring function.

Parameter table

The parameter limits represented in this table have identical permissible ranges. Each parameter may be configured with different settings to create unique trip characteristics for specific thresholds.

Level	Text	Setting range	Default value
Overload (the hysteresis is 1 % of the rated value)			
Level 1	Monitoring	On / Off	On
	Limit	50.0 to 300.0 %	110.0 %
	Delay	0.02 to 99.99 s	11.00 s
	Alarm class	A/B/C/D/E/F	B
	Self acknowledgment	Yes / No	No
Level 2	Monitoring	On / Off	On
	Limit	50.0 to 300.0 %	120.0 %
	Delay	0.02 to 99.99 s	0.10 s
	Alarm class	A/B/C/D/E/F	E
	Self acknowledgment	Yes / No	No

Table 3-17: Monitoring - standard values - generator overload IOP

EN	Monitoring				
DE	Überwachung				
CL2	{0}	{10}	{10c}	{20c}	
2300	✓	✓	✓	✓	
2306					

Gen. overload IOP: Monitoring (Level 1/Level 2) **On / Off**

On Overload monitoring is carried out according to the following parameters. Monitoring is performed at two levels. Both values may be configured independent from each other (prerequisite: Level 1 limit < Level 2 limit).

Off Monitoring is disabled for Level 1 limit and/or Level 2 limit.

EN	Limit				
DE	Grenzwert				
CL2	{0}	{10}	{10c}	{20c}	
2304	✓	✓	✓	✓	
2310					

Gen. overload IOP: Threshold value (Level 1/Level 2) **50.0 to 300.00 %**

ⓘ This value refers to the Generator rated active power (parameter 1752 on page 40).

The percentage values that are to be monitored for each threshold limit are defined here. If this value is reached or exceeded for at least the delay time without interruption, the action specified by the alarm class is initiated.

EN	Delay				
DE	Verzögerung				
CL2	{0}	{10}	{10c}	{20c}	
2305	✓	✓	✓	✓	
2311					

Gen. overload IOP: Delayed (Level 1/Level 2) **0.02 to 99.99 s**

If the monitored generator load exceeds the threshold value for the delay time configured here, an alarm will be issued. If the monitored generator load falls below the threshold (minus the hysteresis) before the delay expires the time will be reset.

EN	Alarm class				
DE	Alarmklasse				
CL2	{0}	{10}	{10c}	{20c}	
2301	✓	✓	✓	✓	
2307					

Gen. overload IOP: Alarm class (Level 1/Level 2) **Class A/B/C/D/E/F**

ⓘ See chapter "Alarm" on page 271.

Each limit may be assigned an independent alarm class that specifies what action should be taken when the limit is surpassed.-

DE	Self acknowledge			
	{0}	{1o}	{1oc}	{2oc}
CL2	✓	✓	✓	✓
2302				
2308				

Gen. overload IOP: Self acknowledgment (Level 1/Level 2) Yes / No

Yes.....The control automatically clears the alarm if the fault condition is no longer detected.

NoThe control does not automatically reset the alarm when the fault condition is no longer detected. The alarm must be acknowledged and reset by manually pressing the appropriate buttons or by activating the *LogicsManager* output "External acknowledgement" (via a discrete input or via an interface).

Configure Monitoring: Generator, Overload MOP (Levels 1 & 2) ANSI# 32

(MOP = Mains Parallel Operation)

The power produced by the generator is calculated from the voltage and current values measured in accordance with how parameters "Generator voltage measuring" (parameter 1851 on page 42) and "Generator current measuring" (parameter 1850 on page 42) are configured. The controller monitors if the system is in a mains parallel or an isolated operation. When the controller detects that the system is operating parallel with the mains, the Generator Overload IOP (refer to page 63) monitoring is disabled. If the measured generator real power during a mains parallel operation is above the configured limit an alarm will be issued.

If this protective function is triggered, the display indicates "Gen. Overload MOP 1" or "Gen. Overload MOP 2" and the logical command variable "06.23" or "06.24" will be enabled.

Refer to Appendix E: Triggering Characteristics, Figure 3-37 on page 324 for the triggering characteristic of this monitoring function.

Parameter table

The parameter limits represented in this table have identical permissible ranges. Each parameter may be configured with different settings to create unique trip characteristics for specific thresholds.

Level	Text	Setting range	Default value
Overload (the hysteresis is 1 % of the rated value)			
Level 1	Monitoring	On / Off	On
	Limit	50.0 to 300.0 %	110.0 %
	Delay	0.02 to 99.99 s	11.00 s
	Alarm class	A/B/C/D/E/F	B
	Self acknowledgment	Yes / No	No
Level 2	Monitoring	On / Off	On
	Limit	50.0 to 300.0 %	120.0 %
	Delay	0.02 to 99.99 s	0.10 s
	Alarm class	A/B/C/D/E/F	E
	Self acknowledgment	Yes / No	No

Table 3-18: Monitoring - standard values - generator overload MOP

EN	Monitoring			
DE	Überwachung			
CL2	{0}	{1o}	{1oc}	{2oc}
2350	✓	✓	✓	✓
2356				

Gen. overload MOP: Monitoring (Level 1/Level 2) On / Off

On Overload monitoring is carried out according to the following parameters. Monitoring is performed at two levels. Both values may be configured independent from each other (prerequisite: Level 1 limit < Level 2 limit).

Off Monitoring is disabled for Level 1 limit and/or Level 2 limit.

EN	Limit			
DE	Grenzwert			
CL2	{0}	{1o}	{1oc}	{2oc}
2354	✓	✓	✓	✓
2360				

Gen. overload MOP: Threshold value (Level 1/Level 2) 50.0 to 300.00 %

ⓘ This value refers to the Generator rated active power (parameter 1752 on page 40).

The percentage values that are to be monitored for each threshold limit are defined here. If this value is reached or exceeded for at least the delay time without interruption, the action specified by the alarm class is initiated.

EN	Delay			
DE	Verzögerung			
CL2	{0}	{1o}	{1oc}	{2oc}
2355	✓	✓	✓	✓
2361				

Gen. overload MOP: Delay (Level 1/Level 2) 0.02 to 99.99 s

If the monitored generator load exceeds the threshold value for the delay time configured here, an alarm will be issued. If the monitored generator load falls below the threshold (minus the hysteresis) before the delay expires the time will be reset.

EN	Alarm class			
DE	Alarmklasse			
CL2	{0}	{1o}	{1oc}	{2oc}
2351	✓	✓	✓	✓
2357				

Gen. overload MOP: Alarm class (Level 1/Level 2) Class A/B/C/D/E/F

ⓘ See chapter "Alarm" on page 271.

Each limit may be assigned an independent alarm class that specifies what action should be taken when the limit is surpassed.

DE EN	Self acknowledge			
	{0}	{1o}	{1oc}	{2oc}
CL2	✓	✓	✓	✓
2352				
2358				

Gen. overload MOP: Self acknowledgment (Level 1/Level 2) Yes / No

Yes.....The control automatically clears the alarm if the fault condition is no longer detected.

NoThe control does not automatically reset the alarm when the fault condition is no longer detected. The alarm must be acknowledged and reset by manually pressing the appropriate buttons or by activating the *LogicsManager* output "External acknowledgement" (via a discrete input or via an interface).

Configure Monitoring: Generator, Unbalanced Load (Levels 1 & 2) ANSI# 46

Unbalanced load is monitored according to how the parameters "Generator voltage measuring" (parameter 1851 on page 42) and "Generator current measuring" (parameter 1850 on page 42) are configured. The unbalanced load alarm monitors the individual phase currents of the generator. The percentage threshold value is the permissible variation of one phase from the average measured current of all three phases.

If this protective function is triggered, the display indicates "**Unbalanced load 1**" or "**Unbalanced load 2**" and the logical command variable "06.16" or "06.17" will be enabled.

Refer to Appendix E: Triggering Characteristics, Figure 3-40 on page 327 for the triggering characteristic of this monitoring function.

Parameter table

The parameter limits represented in this table have identical permissible ranges. Each parameter may be configured with different settings to create unique trip characteristics for specific thresholds.

Level	Text	Setting range	Default value
Unbalanced load (the hysteresis is 1 % of the rated value)			
Level 1	Monitoring	On / Off	On
	Limit	0.0 to 100.0 %	10.0 %
	Delay	0.02 to 99.99 s	10.00 s
	Alarm class	A/B/C/D/E/F	B
	Self acknowledgment	Yes / No	No
	Delayed by engine speed	Yes / No	No
Level 2	Monitoring	On / Off	On
	Limit	0.0 to 100.0 %	15.0 %
	Delay	0.02 to 99.99 s	1.00 s
	Alarm class	A/B/C/D/E/F	E
	Self acknowledgment	Yes / No	No
	Delayed by engine speed	Yes / No	No

Table 3-19: Monitoring - standard values - generator unbalanced load



NOTE

This monitoring function is only enabled when Generator voltage measuring (parameter 1851) is configured to "3Ph 4W" or "3Ph 3W" and Generator current measuring (parameter 1850) is configured to "L1 L2 L3".

Formulas for calculation

	Phase L1	Phase L2	Phase L3
Exceeding	$I_{L1} \geq \frac{3 \times I_N \times P_A + I_{L2} + I_{L3}}{2}$	$I_{L2} \geq \frac{3 \times I_N \times P_A + I_{L1} + I_{L3}}{2}$	$I_{L3} \geq \frac{3 \times I_N \times P_A + I_{L1} + I_{L2}}{2}$
Falling below	$I_{L1} \leq \frac{I_{L2} + I_{L3} - 3 \times I_N \times P_A}{2}$	$I_{L2} \leq \frac{I_{L1} + I_{L3} - 3 \times I_N \times P_A}{2}$	$I_{L3} \leq \frac{I_{L1} + I_{L2} - 3 \times I_N \times P_A}{2}$

Example 1 - exceeding a limit value

Current in phase L1 = current in phase L3

Current in phase L2 has been **exceeded** P_Atripping value percentage (example 10 %) I_Nrated current (example 300 A)

Tripping value for phase L2:

$$I_{L2} \geq \frac{3 \times I_N \times P_A + I_{L1} + I_{L3}}{2} = \frac{3 \times 300A \times 10\% + 300A + 300A}{2} = \frac{\frac{3 \times 300A \times 10}{100} + 300A + 300A}{2} = 345A$$

Example 2 – falling below a limit value

Current in phase L2 = current in phase L3

Current in phase L1 has been **undershot** P_Atripping value percentage (example 10 %) I_Nrated current (example 300 A)

Tripping value for phase L1:

$$I_{L1} \leq \frac{I_{L2} + I_{L3} - 3 \times I_N \times P_A}{2} = \frac{300A + 300A - 3 \times 300A \times 10\%}{2} = \frac{300A + 300A - \frac{3 \times 300A \times 10}{100}}{2} = 255A$$

Parameters

EN	Monitoring			
DE	Überwachung			
CL2	{0}	{1o}	{1oc}	{2oc}
2400	✓	✓	✓	✓
2406				

Gen. unbalanced load: Monitoring (Level 1/Level 2) **On / Off**

On Unbalanced load monitoring is carried out according to the following parameters. Monitoring is performed at two levels. Both values may be configured independent from each other (condition: Level 1 < Level 2).
Off..... No monitoring is carried out for either Level 1 limit or Level 2 limit.

EN	Limit			
DE	Grenzwert			
CL2	{0}	{1o}	{1oc}	{2oc}
2404	✓	✓	✓	✓
2410				

Gen. unbalanced load: Threshold value (Level 1/Level 2) **0.0 to 100.0 %**

ⓘ This value refers to the Generator rated current (parameter 1754 on page 40).

The percentage value that is to be monitored is defined here. If the current in one phase differs from the average value of all three phases by more than this value for at least the delay time without interruption, the action specified by the alarm class is initiated.

EN	Delay			
DE	Verzögerung			
CL2	{0}	{1o}	{1oc}	{2oc}
2405	✓	✓	✓	✓
2411				

Gen. unbalanced load: Delay (Level 1/Level 2) **0.02 to 99.99 s**

If the monitored current exceeds the average value of all three phases by more than the threshold value for the delay time configured here, an alarm will be issued. If the monitored current falls below the threshold (minus the hysteresis) before the delay expires the time will be reset.

EN	Alarm class			
DE	Alarmlklasse			
CL2	{0}	{1o}	{1oc}	{2oc}
2401	✓	✓	✓	✓
2407				

Gen. unbalanced load: Alarm class (Level 1/Level 2) **Class A/B/C/D/E/F**

ⓘ See chapter "Alarm" on page 271.

Each limit may be assigned an independent alarm class that specifies what action should be taken when the limit is surpassed.

EN	Self acknowledge			
DE	Selbstquittierend			
CL2	{0}	{1o}	{1oc}	{2oc}
2402	✓	✓	✓	✓
2408				

Gen. unbalanced load: Self acknowledgment (Level 1/Level 2) **Yes / No**

Yes The control automatically clears the alarm if the fault condition is no longer detected.
No..... The control does not automatically reset the alarm when the fault condition is no longer detected. The alarm must be acknowledged and reset by manually pressing the appropriate buttons or by activating the *LogicsManager* output "External acknowledgement" (via a discrete input or via an interface).

EN	Delayed by engine speed			
DE	Verzögert durch Motordrehzahl			
CL2	{0}	{1o}	{1oc}	{2oc}
2403	✓	✓	✓	✓
2409				

Gen. unbalanced load: Engine delayed monitoring (Level 1/Level 2) **Yes / No**

Yes Monitoring for fault conditions is not performed until engine delayed monitoring is enabled. The engine monitoring delay time (parameter 3315 on page 186) must expire prior to fault monitoring being enabled for parameters assigned this delay.
No..... Monitoring for this fault condition is continuously enabled regardless of engine speed.

Configure Monitoring: Generator, Voltage Asymmetry

The voltage asymmetry alarm monitors the individual three-phase voltages of the generator. Voltage asymmetry monitoring is always performed phase-phase (delta). The percentage threshold value is the permissible variation from the average measured voltage of all three phases. If a measured voltage exceeds a configured permissible asymmetrical voltage deviation from the average voltage value, an alarm is issued.

If this protective function is triggered, the display indicates "**Gen. volt. asymmetry**" and the logical command variable "06.18" will be enabled.

Refer to Appendix E: Triggering Characteristics, Figure 3-41 on page 328 for the triggering characteristic of this monitoring function.

Parameter table

Level	Text	Setting range	Default value
Generator voltage asymmetry (the hysteresis is 0.7 % of the rated value).			
	Monitoring	On / Off	On
	Limit	0.5 to 15.0 %	10.0 %
	Delay	0.02 to 99.99 s	5.00 s
	Alarm class	A/B/C/D/E/F	F
	Self acknowledgment	Yes / No	No
	Delayed by engine speed	Yes / No	Yes

Table 3-20: Monitoring - standard values - generator voltage asymmetry



NOTE

This monitoring function is only enabled if Generator voltage measuring (parameter 1851) is configured to "3Ph 4W" or "3Ph 3W".

EN	Monitoring			
DE	Überwachung			
CL2	{0}	{1o}	{1oc}	{2oc}
3900	✓	✓	✓	✓

Gen. voltage asymmetry: Monitoring **On / Off**

On Voltage asymmetry monitoring is carried out according to the following parameters.

Off No monitoring is carried out.

EN	Limit			
DE	Grenzwert			
CL2	{0}	{1o}	{1oc}	{2oc}
3903	✓	✓	✓	✓

Gen. voltage asymmetry: Threshold value **0.5 to 15.0 %**

ⓘ This value refers to Generator rated voltage (parameter 1766 on page 40).

The percentage value that is to be monitored is defined here. If the voltage in one phase differs from the average value of all three phases by more than this value for at least the delay time without interruption, the action specified by the alarm class is initiated.

EN	Delay			
DE	Verzögerung			
CL2	{0}	{1o}	{1oc}	{2oc}
3904	✓	✓	✓	✓

Gen. voltage asymmetry: Delay **0.02 to 99.99 s**

If the monitored generator voltage asymmetry exceeds the threshold value for the delay time configured here, an alarm will be issued. If the monitored generator voltage asymmetry falls below the threshold (minus the hysteresis) before the delay expires the time will be reset.

EN	Alarm class			
DE	Alarmklasse			
CL2	{0}	{1o}	{1oc}	{2oc}
3901	✓	✓	✓	✓

Gen. voltage asymmetry: Alarm class **Class A/B/C/D/E/F**

ⓘ See chapter "Alarm" on page 271.

Each limit may be assigned an independent alarm class that specifies what action should be taken when the limit is surpassed.

EN	Self acknowledge				
DE	Selbstquittierend				
CL2	{0}	{1o}	{1oc}	{2oc}	
3902	✓	✓	✓	✓	

Gen. voltage asymmetry: Self acknowledgment Yes / No

Yes The control automatically clears the alarm if the fault condition is no longer detected.

No..... The control does not automatically reset the alarm when the fault condition is no longer detected. The alarm must be acknowledged and reset by manually pressing the appropriate buttons or by activating the *LogicsManager* output "External acknowledgement" (via a discrete input or via an interface).

EN	Delayed by engine speed				
DE	Verzögert durch Motordrehzahl				
CL2	{0}	{1o}	{1oc}	{2oc}	
3905	✓	✓	✓	✓	

Gen. voltage asymmetry: Engine delayed monitoring Yes / No

Yes Monitoring for fault conditions is not performed until engine delayed monitoring is enabled. The engine monitoring delay time (parameter 3315 on page 186) must expire prior to fault monitoring being enabled for parameters assigned this delay.

No..... Monitoring for this fault condition is continuously enabled regardless of engine speed.

Configure Monitoring: Generator, Ground Fault (Levels 1 & 2)

Mains Current Input is Configured for Mains Current (Calculated Ground Fault)

(Refer to parameter 1854 on page 43)

The current produced by the generator is monitored depending on how parameter "Generator current measuring" (parameter 1850 on page 42) is configured. The measured three conductor currents I_{Gen-L1} , I_{Gen-L2} and I_{Gen-L3} are vectorially totaled ($I_S = I_{Gen-L1} + I_{Gen-L2} + I_{Gen-L3}$) and compared with the configured fault limit (the calculated actual value is indicated in the display). If the measured value exceeds the fault threshold limit, a ground fault is present, and an alarm is issued.

If this protective function is triggered, the display indicates "Ground fault 1" or "Ground fault 2" and the logical command variable "06.19" or "06.20" will be enabled.



NOTE

The ground fault protection zone is determined by the location where the generator current transformer are physically installed.

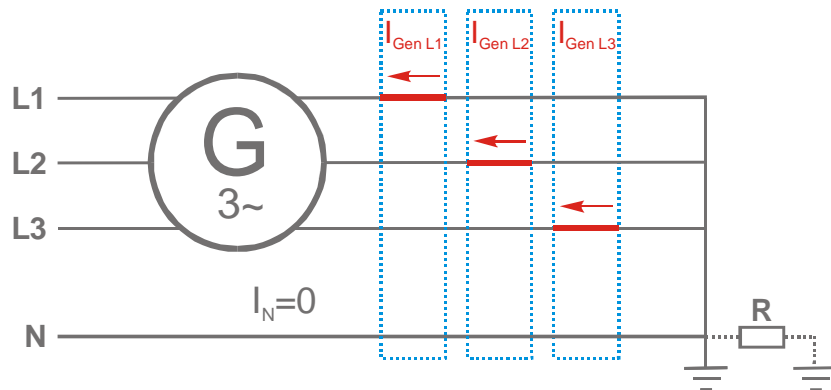

Figure 3-4: Monitoring - calculated generator ground fault

Test: Short-circuit one of the three generator current transformers while the generator is at full load. The measured current should read 100% of rated on the two phases that do not have their current transformers short-circuited.

The ground current calculation does not take current on the neutral conductor into consideration. In order for the controller to be able to perform calculated ground fault current protection accurately, the neutral conductor must not conduct current.

The fault threshold value is configured as a percentage. This percentage threshold refers to the generator rated current (parameter 1754). Due to unavoidable load asymmetries, the minimum value for this parameter should be 10% or greater.

Calculation

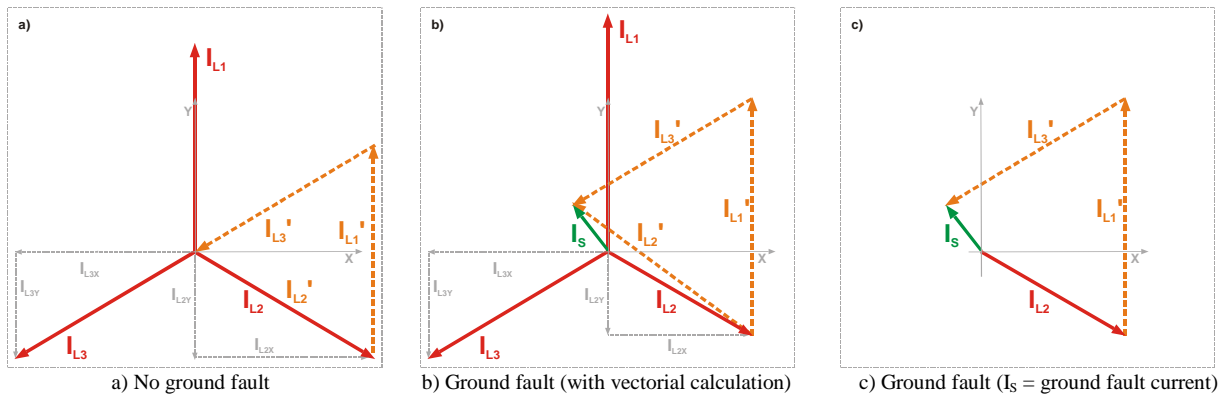

Figure 3-5: Monitoring - calculated generator ground current - vector diagram

The **ground current** I_s is calculated geometrically/vectorially. The pointers for **phase currents** I_{L1} and I_{L2} are parallel shifted and lined up as shown in Figure 3-5 a). The pointer between the neutral point and the point of the shifted **pointer** I_{L2}' results is the **sum current** I_s as shown in Figure 3-5 b). In order to be able to add the pointers vectorially, these must be divided into their X- and Y-coordinates (I_{L2X} , I_{L2Y} , I_{L3X} and I_{L3Y}). The ground fault current may be calculated using the following formula:

$$(I_{L1rated} + I_{L2rated} + I_{L3rated}) - (I_{L1measured} + I_{L2measured} + I_{L3measured}) / 1.73 = I_s$$

$$(7A + 7A + 7A) - (7A + 6.5A + 6A) / 1.73 = 0.866A$$

Results of a calculation example:

- Phase current $I_{L1} = I_{Rated} = 7 A$
- Phase current $I_{L2} = 6.5 A$
- Phase current $I_{L3} = 6 A$
- Sum current (ground fault current) $I_s = 0.866A$.

Mains Current Input is Configured for Ground Current (Measured Ground Fault)

(Refer to parameter 1854 on page 43)

Ground fault current is actively measured when the mains current input is configured to monitor for ground current. The ground fault threshold is configured as a percentage of the value entered for parameter "Ground current transformer" (parameters 1810 or **Fehler! Verweisquelle konnte nicht gefunden werden.** on page 48).



NOTE

The ground fault protection zone is determined by the physical installation location of the generator current transformer.

Parameter table

The parameter limits represented in this table have identical permissible ranges. Each parameter may be configured with different settings to create unique trip characteristics for specific thresholds.

Level	Text	Setting range	Default value
Generator ground fault (the hysteresis is 0.7 % of the rated value)			
Level 1	Monitoring	On / Off	Off
	Limit	0 to 300 %	10 %
	Delay	0.02 to 99.99 s	0.20 s
	Alarm class	A/B/C/D/E/F	B
	Self acknowledgment	Yes / No	No
	Delayed by engine speed	Yes / No	No
Level 2	Monitoring	On / Off	Off
	Limit	0 to 300 %	30 %
	Delay	0.02 to 99.99 s	0.10 s
	Alarm class	A/B/C/D/E/F	F
	Self acknowledgment	Yes / No	No
	Delayed by engine speed	Yes / No	No

Table 3-21: Monitoring - standard values - generator ground fault

Parameter

EN	Monitoring			
DE	Überwachung			
CL2	{0}	{1o}	{1oc}	{2oc}
3250	✓	✓	✓	☑
3256				

Gen. ground fault: Monitoring (Level 1/Level 2) On / Off

On.....Ground current monitoring is carried out according to the following parameters. Monitoring is performed at two levels. Both values may be configured independent from each other (prerequisite: Level 1 < Level 2).

Off.....Monitoring is disabled for Level 1 limit and/or Level 2 limit.

EN	Limit			
DE	Grenzwert			
CL2	{0}	{1o}	{1oc}	{2oc}
3254	✓	✓	✓	☑
3260				

Gen. ground fault: Threshold value (Level 1/Level 2) 0 to 300 %

① This value refers to the Generator rated current of the generator (parameter 1754 on page 40), if the ground current is calculated from the generator current values. It refers to the parameter "Ground current transformer" (parameters 1810 or **Fehler! Verweisquelle konnte nicht gefunden werden.** on page 48), if the ground current is measured directly.

The percentage values that are to be monitored for each threshold limit are defined here. If this value is reached or exceeded for at least the delay time without interruption, the action specified by the alarm class is initiated.



NOTE

The ground fault threshold shall not exceed the mains/ground current measuring range (approx. 1.5 × I_{rated}; refer to the Technical Data section of the Installation Manual 37426).

EN	Delay			
DE	Verzögerung			
CL2	{0}	{1o}	{1oc}	{2oc}
3255	✓	✓	✓	☑
3261				

Gen. ground fault: Delay (Level 1/Level 2) 0.02 to 99.99 s

If the monitored ground fault exceeds the threshold value for the delay time configured here, an alarm will be issued. If the monitored ground fault falls below the threshold (minus the hysteresis) before the delay expires the time will be reset.

EN	Alarm class			
DE	Alarmklasse			
CL2	{0}	{1o}	{1oc}	{2oc}
3251	✓	✓	✓	☑
3257				

Gen. ground fault: Alarm class (Level 1/Level 2) Class A/B/C/D/E/F

① See chapter "Alarm" on page 271.

Each limit may be assigned an independent alarm class that specifies what action should be taken when the limit is surpassed.

EN	Self acknowledge			
DE	Selbstquittierend			
CL2	{0}	{1o}	{1oc}	{2oc}
3252	✓	✓	✓	☑
3258				

Gen. ground fault: Self acknowledgment (Level 1/Level 2) Yes / No

Yes.....The control automatically clears the alarm if the fault condition is no longer detected.

No.....The control does not automatically reset the alarm when the fault condition is no longer detected. The alarm must be acknowledged and reset by manually pressing the appropriate buttons or by activating the *LogicsManager* output "External acknowledgement" (via a discrete input or via an interface).

EN	Delayed by engine speed			
DE	Verzögert durch Motordrehzahl			
CL2	{0}	{1o}	{1oc}	{2oc}
3253	✓	✓	✓	☑
3259				

Gen. ground fault: Engine delayed monitoring (Level 1/Level 2) Yes / No

Yes.....Monitoring for fault conditions is not performed until engine delayed monitoring is enabled. The engine monitoring delay time (parameter 3315 on page 186) must expire prior to fault monitoring being enabled for parameters assigned this delay.

No.....Monitoring for this fault condition is continuously enabled regardless of engine speed.

Configure Monitoring: Generator, Phase Rotation



CAUTION

Ensure that the control unit is properly connected to phase voltages on both sides of the circuit breaker(s) during installation. Failure to do so may result in damage to the control unit and/or generation equipment due to the breaker closing asynchronously or with mismatched phase rotations. Also ensure that phase rotation monitoring is enabled at all connected components (engine, generator, breakers, cable, busbars, etc.).

This function will block a connection of systems with mismatched phases only under the following conditions:

- The voltages being measured are wired correctly with respect to the phase rotation at the measuring points (i.e. the potential transformers in on both sides of the circuit breaker)
- The voltages being measured are wired so that angular phase shifts or any interruptions from the measuring point to the control unit do not exist
- The voltages being measured are wired to the correct terminals of the control unit (i.e. L1 phase of the generator is connected with the terminal of the control unit which is intended for the generator L1 phase)
- The configured alarm class is of class C, D, E, or F (shutdown alarm).

Correct phase rotation of the phase voltages ensures that damage will not occur during a breaker closure to either the mains or the generator. The voltage phase rotation alarm checks the phase rotation of the measured voltages and the configured phase rotation to ensure they are identical. The directions of rotation are differentiated as "clockwise" and "counter clockwise". With a clockwise field the direction of rotation is "L1-L2-L3"; with a counter clockwise field the direction of rotation is "L1-L3-L2". If the control is configured for a clockwise rotation and the measured voltages are monitored as counterclockwise, the alarm will be initiated. The direction of configured rotation being monitored by the control unit is displayed on the screen.

If this protective function is triggered, the display indicates "**Gen.ph.rot. mismatch**" and the logical command variable "06.21" will be enabled.

Parameter table

Level	Text	Setting range	Default value
Generator voltage phase direction fault (the hysteresis is 0.7 % of the rated value)			
	Monitoring	On / Off	On
	Generator phase rotation	CW / CCW	CW
	Alarm class	A/B/C/D/E/F	F
	Self acknowledgment	Yes / No	No
	Delayed by engine speed	Yes / No	Yes

Table 3-22: Monitoring - standard values - generator voltage phase rotation



NOTE

This monitoring function is only enabled if Generator voltage measuring (parameter 1851) is configured to "3Ph 4W" or "3Ph 3W" and the measured voltage exceeds 50 % of the rated voltage (parameter 1766) or if Generator voltage measuring (parameter 1851) is configured to "1Ph 2W" (in this case, the phase rotation is not evaluated, but defined by the 1Ph2W phase rotation (parameter 1859)).

		Monitoring			
		Überwachung			
EN		{0}	{1o}	{1oc}	{2oc}
DE					
CL2		✓	✓	✓	✓
3950					

Gen.voltage phase rotation: Monitoring On / Off

On.....Phase rotation monitoring is carried out according to the following parameters.

Off.....No monitoring is carried out.

		Generator phase rotation			
		Generatordrehfeld			
EN		{0}	{1o}	{1oc}	{2oc}
DE					
CL2		✓	✓	✓	✓
3954					

Gen.voltage phase rotation: Direction CW / CCW

CWThe three-phase measured generator voltage is rotating CW (clock-wise; that means the voltage rotates in L1-L2-L3 direction; standard setting).

CCWThe three-phase measured generator voltage is rotating CCW (counter clock-wise; that means the voltage rotates in L1-L3-L2 direction).

		Alarm class			
		Alarmklasse			
EN		{0}	{1o}	{1oc}	{2oc}
DE					
CL2		✓	✓	✓	✓
3951					

Gen.voltage phase rotation: Alarm class Class A/B/C/D/E/F

| ⓘ See chapter "Alarm" on page 271. |

Each limit may be assigned an independent alarm class that specifies what action should be taken when the limit is surpassed.

		Self acknowledge			
		Selbstquittierend			
EN		{0}	{1o}	{1oc}	{2oc}
DE					
CL2		✓	✓	✓	✓
3952					

Gen.voltage phase rotation: Self acknowledgment (Level 1/Level 2) Yes / No

Yes.....The control automatically clears the alarm if the fault condition is no longer detected.

NoThe control does not automatically reset the alarm when the fault condition is no longer detected. The alarm must be acknowledged and reset by manually pressing the appropriate buttons or by activating the *LogicsManager* output "External acknowledgement" (via a discrete input or via an interface).

		Delayed by engine speed			
		Verzögert durch Motordrehzahl			
EN		{0}	{1o}	{1oc}	{2oc}
DE					
CL2		✓	✓	✓	✓
3953					

Gen.voltage phase rotation: Engine delayed monitoring Yes / No

Yes.....Monitoring for fault conditions is not performed until engine delayed monitoring is enabled. The engine monitoring delay time (parameter 3315 on page 186) must expire prior to fault monitoring being enabled for parameters assigned this delay.

NoMonitoring for this fault condition is continuously enabled regardless of engine speed.

Configure Monitoring: Generator, Inverse Time-Overcurrent Monitoring ANSI# IEC 255

The current produced by the generator is monitored depending on how parameter "Generator current measuring" (parameter 1850 on page 42) is configured. If an overcurrent condition is detected, the fault recognition time is determined by the configured tripping characteristic curve and the measured current. The tripping time is faster as the measured current increases in magnitude according to a defined curve. According to IEC 255 three different characteristics are available.

If this protective function is triggered, the display indicates "Inv. time overcurr." and the logical command variable "06.22" will be enabled.

"Normal inverse" characteristic:
$$t = \frac{0.14}{(I/I_p)^{0.02} - 1} * t_p [s]$$

"Highly inverse" characteristic:
$$t = \frac{13.5}{(I/I_p) - 1} * t_p [s]$$

"Extremely inverse" characteristic:
$$t = \frac{80}{(I/I_p)^2 - 1} * t_p [s]$$

Variable meanings:

t:	tripping time
t _p	setting value time
I	measured fault current
I _p	setting value current

Please take into account during configuration:

for I_{start}: I_{start} > I_n and I_{start} > I_p
 for I_p the smaller I_p is, the steeper is the slope of the tripping curve



NOTE

The maximum tripping time is 327 s. If a tripping time greater than 327 s is configured, an overcurrent fault condition will not be recognized.

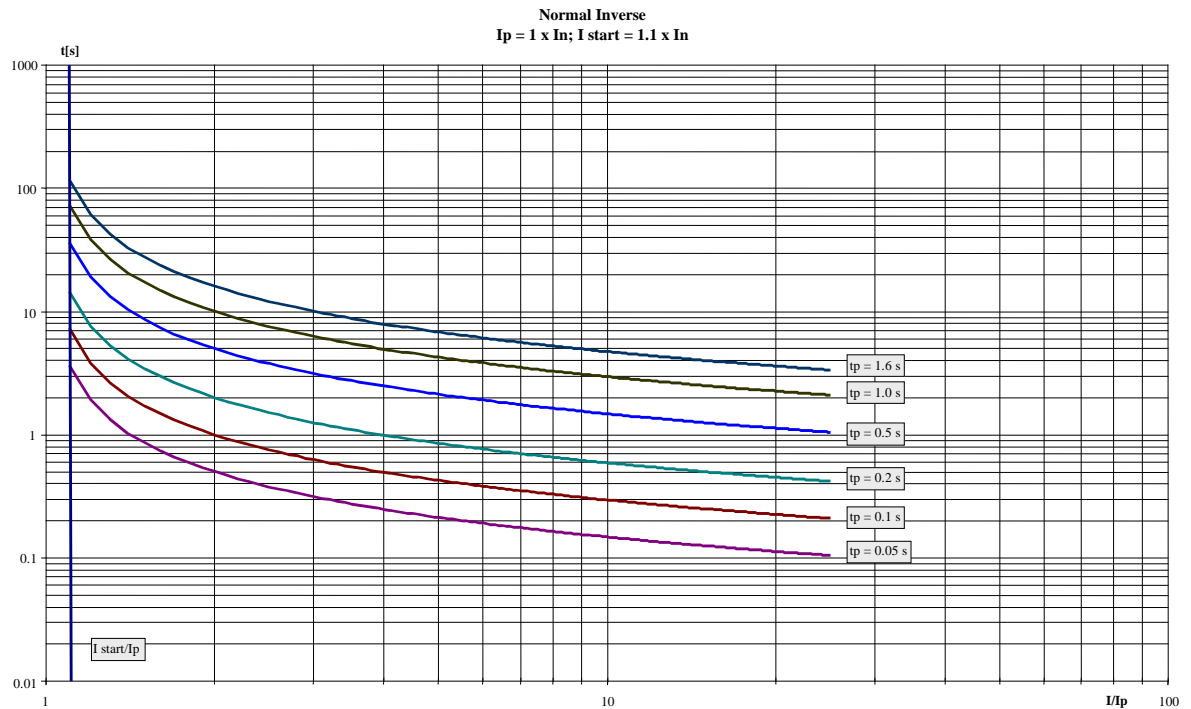

Figure 3-6: Monitoring - generator inverse time-overcurrent - "Normal inverse" characteristic

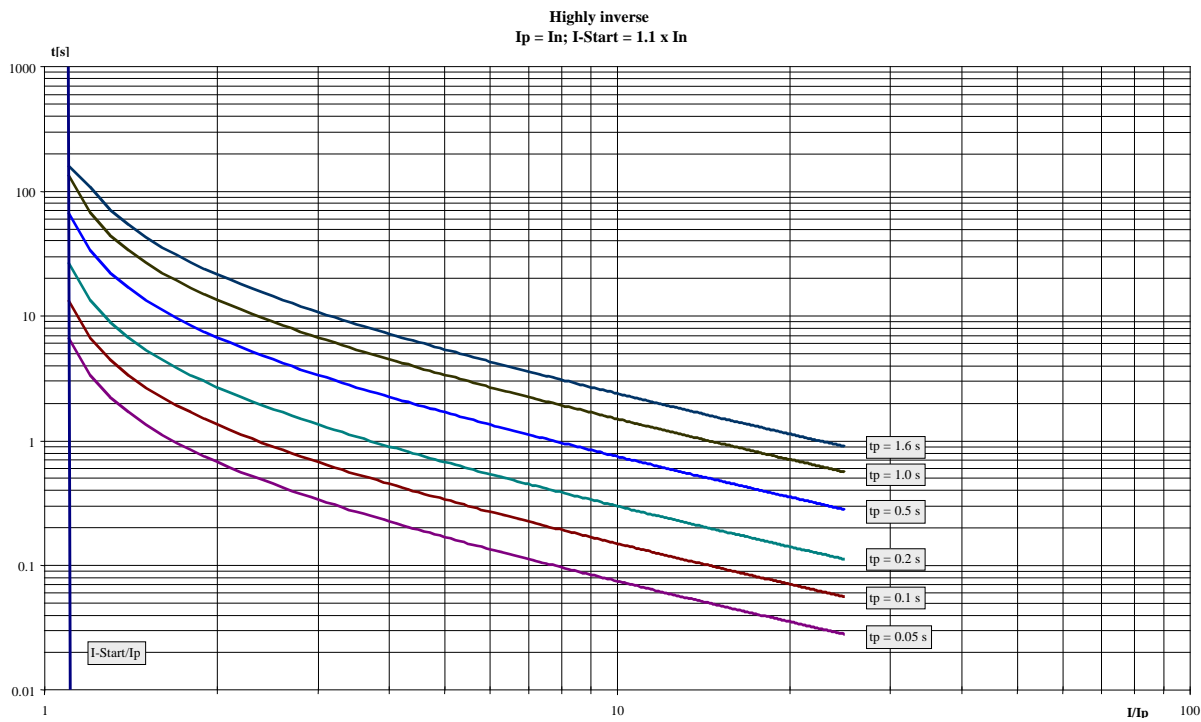

Figure 3-7: Monitoring - generator inverse time-overcurrent - "Highly inverse" characteristic

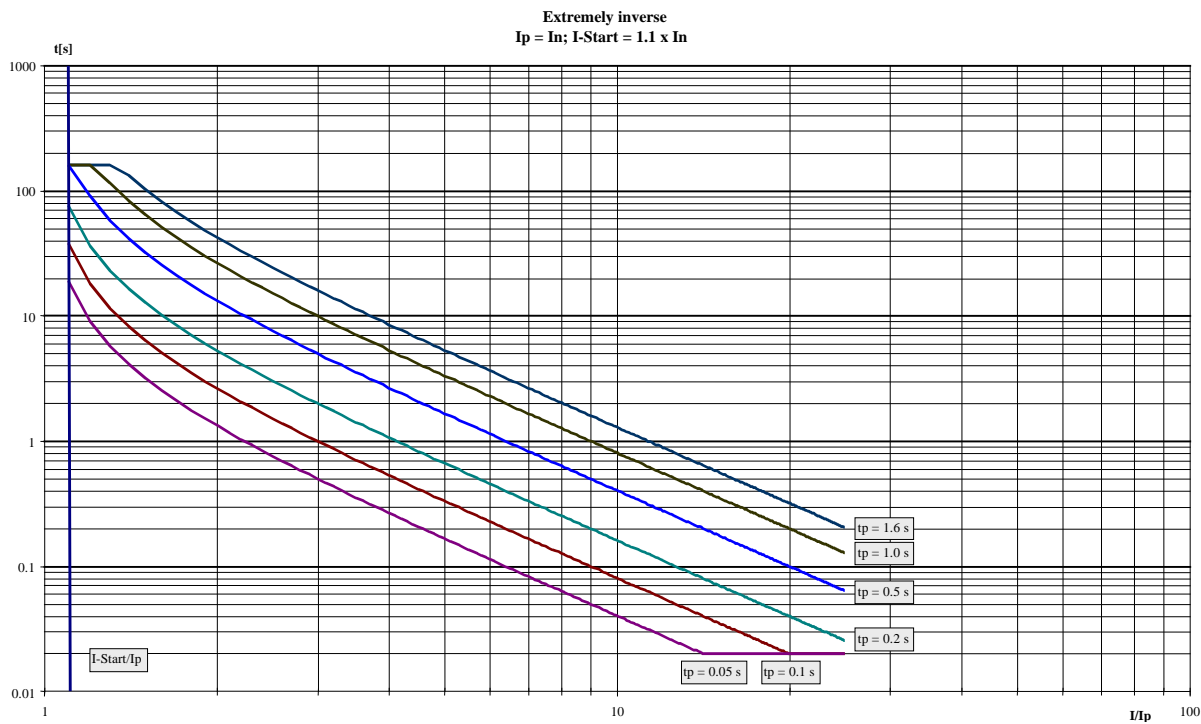

Figure 3-8: Monitoring - generator inverse time-overcurrent - "Extremely inverse" characteristic

Parameter table

Level	Text	Setting range	Default value
Inverse time-overcurrent (the hysteresis is 1 % of the rated value)			
	Monitoring	On / Off	On
	Inverse time characteristic	Normal / High / Extreme	Normal
	Inverse time overcurrent Tp	0.01 to 1.99 s	0.06 s
	Inverse time overcurrent Ip	10.0 to 300.0 %	100.0 %
	Inv. time overcurrent I start	100.0 to 300.0 %	115.0 %
	Alarm class	A/B/C/D/E/F	F
	Self acknowledgment	Yes / No	No
	Delayed by engine speed	Yes / No	No

Table 3-23: Monitoring - standard values - generator inverse time-overcurrent

<p>EN Monitoring</p> <p>DE Überwachung</p> <p>CL2 {0} {1o} {1oc} {2oc}</p> <p>4030 ✓ ✓ ✓ ✓</p>	<p>Gen. overcurrent, inverse: Monitoring On / Off</p> <hr/> <p>On Overcurrent monitoring is carried out according to the following parameters.</p> <p>Off..... No monitoring is carried out.</p>
<p>EN Inverse time characteristic</p> <p>DE Überstrom Charakteristik</p> <p>CL2 {0} {1o} {1oc} {2oc}</p> <p>4034 ✓ ✓ ✓ ✓</p>	<p>Gen. overcurrent, inverse: Tripping characteristic Normal / High / Extreme</p> <hr/> <p>Selection of the used overcurrent characteristic.</p> <p>Normal..... The "normal inverse" tripping curve will be used</p> <p>High The "highly inverse" tripping curve will be used</p> <p>Extreme..... The "extremely inverse" tripping curve will be used.</p>
<p>EN Inverse time overcurrent Tp=</p> <p>DE Überstrom (AMZ) Tp=</p> <p>CL2 {0} {1o} {1oc} {2oc}</p> <p>4035 ✓ ✓ ✓ ✓</p>	<p>Gen. overcurrent, inverse: Time constant Tp 0.01 to 1.99 s</p> <hr/> <p>Time constant Tp used to calculate the characteristics.</p>
<p>EN Inverse time overcurr. Ip=</p> <p>DE Überstrom (AMZ) Ip=</p> <p>CL2 {0} {1o} {1oc} {2oc}</p> <p>4036 ✓ ✓ ✓ ✓</p>	<p>Gen. overcurrent, inverse: Current constant Ip 10.0 to 300.0 %</p> <hr/> <p>Current constant Ip used to calculate the characteristics.</p>
<p>EN Inv time overcurr. I-start=</p> <p>DE Überstrom (AMZ) I-Start=</p> <p>CL2 {0} {1o} {1oc} {2oc}</p> <p>4037 ✓ ✓ ✓ ✓</p>	<p>Gen. overcurrent, inverse: I start 100.0 to 300.0 %</p> <hr/> <p>Lower tripping value for inverse time-overcurrent protection. If the monitored current is less than I_{start}, the inverse time-overcurrent protection does not trip. If I_{start} is less than I_p, I_p is used as the lower tripping value.</p>

		Alarm class			
DE	EN	Alarmklasse			
CL2	{0}	{1o}	{1oc}	{2oc}	
4031	✓	✓	✓	✓	

Gen. overcurrent, inverse: Alarm class Class A/B/C/D/E/F

| ⓘ See chapter "Alarm" on page 271. |

Each limit may be assigned an independent alarm class that specifies what action should be taken when the limit is surpassed.

		Self acknowledge			
DE	EN	Selbstquittierend			
CL2	{0}	{1o}	{1oc}	{2oc}	
4032	✓	✓	✓	✓	

Gen. overcurrent, inverse: Self acknowledgment Yes / No

Yes.....The control automatically clears the alarm if the fault condition is no longer detected.

No.....The control does not automatically reset the alarm when the fault condition is no longer detected. The alarm must be acknowledged and reset by manually pressing the appropriate buttons or by activating the *LogicsManager* output "External acknowledgement" (via a discrete input or via an interface).

		Delayed by engine speed			
DE	EN	Verzögert durch Motordrehzahl			
CL2	{0}	{1o}	{1oc}	{2oc}	
4033	✓	✓	✓	✓	

Gen. overcurrent, inverse: Engine delayed monitoring Yes / No

Yes.....Monitoring for fault conditions is not performed until engine delayed monitoring is enabled. The engine monitoring delay time (parameter 3315 on page 186) must expire prior to fault monitoring being enabled for parameters assigned this delay.

No.....Monitoring for this fault condition is continuously enabled regardless of engine speed.

Configure Monitoring: Generator, Lagging Power Factor Monitoring (Levels 1 & 2)

The power factor is monitored for becoming more lagging (i.e. inductive) than an adjustable limit. This limit may be a lagging or leading power factor limit. There are two lagging power factor alarm levels available in the control. This monitoring function may be used for monitoring an overexcitation with a warning and a shutdown alarm level. Both alarms are definite time alarms. Refer to the Application Manual 37429 for a detailed description of this monitoring function.

Figure 3-9 shows an example of a leading and a lagging power factor limit and the power factor range, for which the lagging power factor monitoring issues an alarm.

If this protective function is triggered, the display indicates "Gen. PF lagging 1" or "Gen. PF lagging 2" and the logical command variable "06.25" or "06.26" will be enabled.

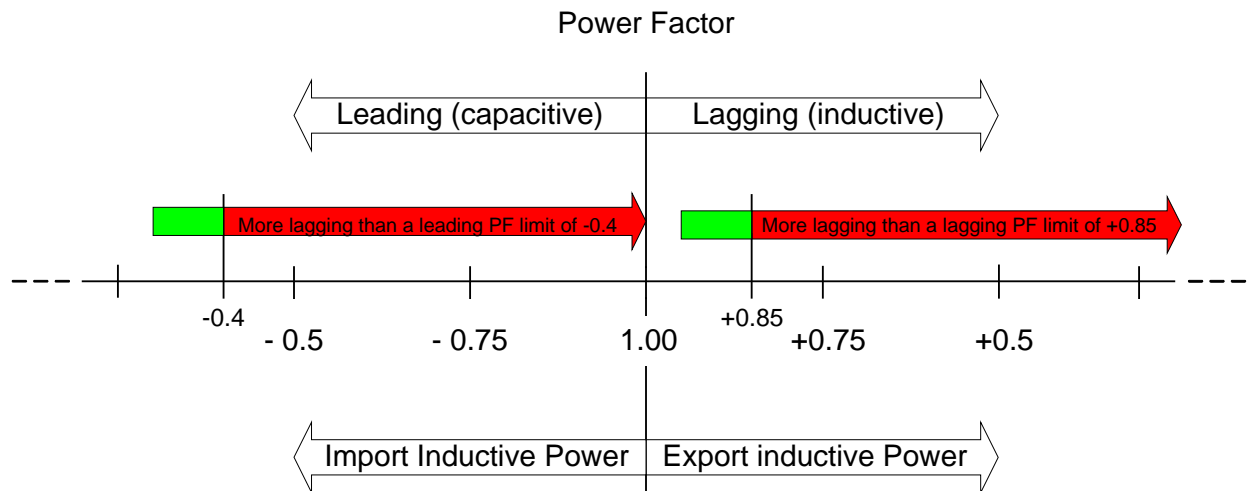

Figure 3-9: Monitoring - generator lagging power factor

Parameter table

The parameter limits represented in this table have identical permissible ranges. Each parameter may be configured with different settings to create unique trip characteristics for specific thresholds.

Level	Text	Setting range	Default value
Generator lagging power factor			
Level 1	Monitoring	On / Off	On
	Limit	-0.001 to +0.001	+0.900
	Delay	0.02 to 99.99 s	30.00 s
	Alarm class	A/B/C/D/E/F	B
	Self acknowledgment	Yes / No	No
	Delayed by engine speed	Yes / No	Yes
Level 2	Monitoring	On / Off	On
	Limit	-0.001 to +0.001	+0.700
	Delay	0.02 to 99.99 s	1.00 s
	Alarm class	A/B/C/D/E/F	E
	Self acknowledgment	Yes / No	No
	Delayed by engine speed	Yes / No	Yes

Table 3-24: Monitoring - standard values - generator lagging power factor

EN		Monitoring			
DE		Überwachung			
CL2	{0}	{1o}	{1oc}	{2oc}	
2325	✓	✓	✓	✓	
2331					

Gen. lagging power factor: Monitoring (Level 1/Level 2) **On / Off**

On.....Generator lagging power factor monitoring is carried out according to the following parameters. Monitoring is performed at two levels. Both values may be configured independent from each other.
Off.....Monitoring is disabled for Level 1 limit and/or Level 2 limit.

EN		Limit			
DE		Grenzwert			
CL2	{0}	{1o}	{1oc}	{2oc}	
2329	✓	✓	✓	✓	
2335					

Gen. lagging power factor: Threshold value (Level 1/Level 2) **-0.001 to +0.001**

The values that are to be monitored for each threshold limit are defined here. If the power factor becomes more lagging (i.e. inductive, refer to Figure 3-9) than a lagging PF value (positive) or a leading PF value (negative) for at least the delay time (parameters 2330 or 2336) without interruption, the action specified by the alarm class is initiated.

EN		Delay			
DE		Verzögerung			
CL2	{0}	{1o}	{1oc}	{2oc}	
2330	✓	✓	✓	✓	
2336					

Gen. lagging power factor: Delay (Level 1/Level 2) **0.02 to 99.99 s**

If the monitored generator power factor is more lagging than the configured limit for the delay time configured here, an alarm will be issued. If the monitored generator power factor returns within the limit before the delay expires the time will be reset.

EN		Alarm class			
DE		Alarmklasse			
CL2	{0}	{1o}	{1oc}	{2oc}	
2326	✓	✓	✓	✓	
2332					

Gen. lagging power factor: Alarm class (Level 1/Level 2) **Class A/B/C/D/E/F**

| ⓘ See chapter "Alarm" on page 271. |

Each limit may be assigned an independent alarm class that specifies what action should be taken when the limit is surpassed.

EN		Self acknowledge			
DE		Selbstquittierend			
CL2	{0}	{1o}	{1oc}	{2oc}	
2327	✓	✓	✓	✓	
2333					

Gen. lagging power factor: Self acknowledgment (Level 1/Level 2) **Yes / No**

Yes.....The control automatically clears the alarm if the fault condition is no longer detected.
No.....The control does not automatically reset the alarm when the fault condition is no longer detected. The alarm must be acknowledged and reset by manually pressing the appropriate buttons or by activating the *LogicsManager* output "External acknowledgement" (via a discrete input or via an interface).

EN		Delayed by engine speed			
DE		Verzögert durch Motordrehzahl			
CL2	{0}	{1o}	{1oc}	{2oc}	
2328	✓	✓	✓	✓	
2334					

Gen. lagging power factor: Engine delayed monitoring (Level 1/Level 2) **Yes / No**

Yes.....Monitoring for fault conditions is not performed until engine delayed monitoring is enabled. The engine monitoring delay time (parameter 3315 on page 186) must expire prior to fault monitoring being enabled for parameters assigned this delay.
No.....Monitoring for this fault condition is continuously enabled regardless of engine speed.

Configure Monitoring: Generator, Leading Power Factor Monitoring (Levels 1 & 2)

The power factor is monitored for becoming more leading (i.e. capacitive) than an adjustable limit. This limit may be a leading or lagging power factor limit. There are two leading power factor alarm levels available in the control. This monitoring function may be used for monitoring an underexcitation with a warning and a shutdown alarm level. Both alarms are definite time alarms. Refer to the Application Manual 37429 for a detailed description of this monitoring function.

Figure 3-10 shows an example of a leading and a lagging power factor limit and the power factor range, for which the leading power factor monitoring issues an alarm.

If this protective function is triggered, the display indicates "Gen. PF leading 1" or "Gen. PF leading 2" and the logical command variable "06.27" or "06.28" will be enabled.

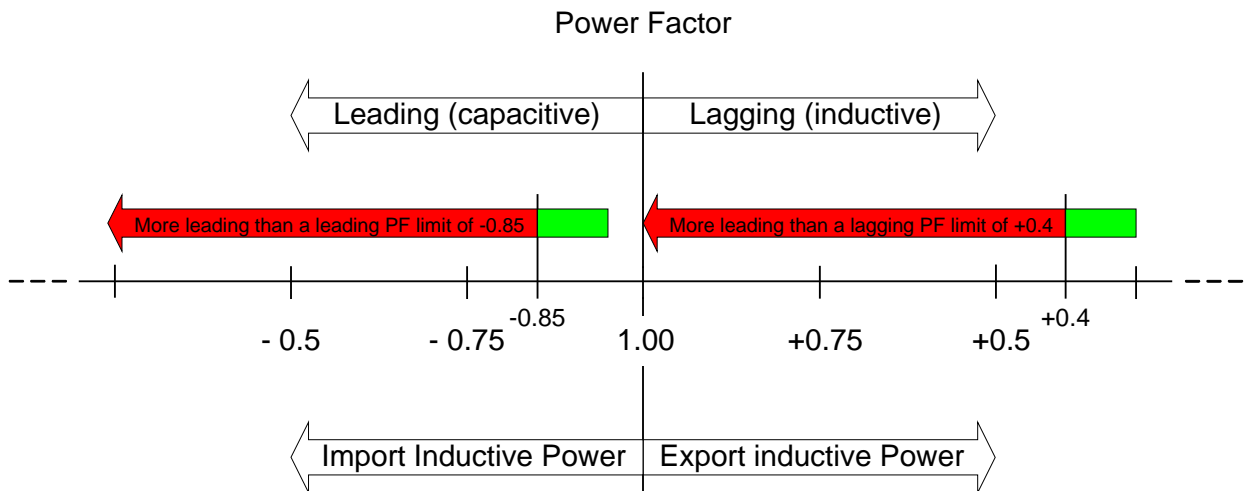

Figure 3-10: Monitoring - generator leading power factor

Parameter table

The parameter limits represented in this table have identical permissible ranges. Each parameter may be configured with different settings to create unique trip characteristics for specific thresholds.

Level	Text	Setting range	Default value
Generator leading power factor			
Level 1	Monitoring	On / Off	On
	Limit	-0.001 to +0.001	-0.900
	Delay	0.02 to 99.99 s	30.00 s
	Alarm class	A/B/C/D/E/F	B
	Self acknowledgment	Yes / No	No
	Delayed by engine speed	Yes / No	Yes
Level 2	Monitoring	On / Off	On
	Limit	-0.001 to +0.001	-0.700
	Delay	0.02 to 99.99 s	1.00 s
	Alarm class	A/B/C/D/E/F	E
	Self acknowledgment	Yes / No	No
	Delayed by engine speed	Yes / No	Yes

Table 3-25: Monitoring - standard values - generator leading power factor

		Monitoring			
		Überwachung			
CL2	{0}	{1o}	{1oc}	{2oc}	
2375	✓	✓	✓	✓	
2381					

Gen. leading power factor: Monitoring (Level 1/Level 2) On / Off

On Generator leading power factor monitoring is carried out according to the following parameters. Monitoring is performed at two levels. Both values may be configured independent from each other.
Off Monitoring is disabled for Level 1 limit and/or Level 2 limit.

		Limit			
		Grenzwert			
CL2	{0}	{1o}	{1oc}	{2oc}	
2379	✓	✓	✓	✓	
2385					

Gen. leading power factor: Threshold value (Level 1/Level 2) -0.001 to +0.001

The values that are to be monitored for each threshold limit are defined here. If the power factor becomes more leading (i.e. capacitive, refer to Figure 3-10) than a leading PF value (negative) or a lagging PF value (positive) for at least the delay time (parameters 2380 or 2386) without interruption, the action specified by the alarm class is initiated.

		Delay			
		Verzögerung			
CL2	{0}	{1o}	{1oc}	{2oc}	
2380	✓	✓	✓	✓	
2386					

Gen. leading power factor: Delay (Level 1/Level 2) 0.02 to 99.99 s

If the monitored generator power factor is more leading than the configured limit for the delay time configured here, an alarm will be issued. If the monitored generator power factor returns within the limit before the delay expires the time will be reset.

		Alarm class			
		Alarmklasse			
CL2	{0}	{1o}	{1oc}	{2oc}	
2376	✓	✓	✓	✓	
2382					

Gen. leading power factor: Alarm class (Level 1/Level 2) Class A/B/C/D/E/F

ⓘ See chapter "Alarm" on page 271.

Each limit may be assigned an independent alarm class that specifies what action should be taken when the limit is surpassed.

		Self acknowledge			
		Selbstquittierend			
CL2	{0}	{1o}	{1oc}	{2oc}	
2377	✓	✓	✓	✓	
2383					

Gen. leading power factor: Self acknowledgment (Level 1/Level 2) Yes / No

Yes The control automatically clears the alarm if the fault condition is no longer detected.
No The control does not automatically reset the alarm when the fault condition is no longer detected. The alarm must be acknowledged and reset by manually pressing the appropriate buttons or by activating the *LogicsManager* output "External acknowledgement" (via a discrete input or via an interface).

		Delayed by engine speed			
		Verzögert durch Motordrehzahl			
CL2	{0}	{1o}	{1oc}	{2oc}	
2378	✓	✓	✓	✓	
2384					

Gen. leading power factor: Delayed engine speed (Level 1/Level 2) Yes / No

Yes Monitoring for fault conditions is not performed until engine delayed monitoring is enabled. The engine monitoring delay time (parameter 3315 on page 186) must expire prior to fault monitoring being enabled for parameters assigned this delay.
No Monitoring for this fault condition is continuously enabled regardless of engine speed.

Configure Monitoring: Mains

Parameter Table

Level	Text	Setting range	Default value
Configure mains monitoring			
	Mains voltage monitoring	Phase - phase / Phase - neutral	Phase - phase
	Mains settling time	0 to 9999 s	20 s

Table 3-26: Monitoring - standard values - configure mains monitoring

EN	Mains voltage monitoring				
DE	Netzspannungsüberwachung				
CL2	{0}	{1o}	{1oc}	{2oc}	
1771	✓	✓	✓	✓	

Mains protection: Type of monitoring

Phase - phase / Phase - neutral

The unit can either monitor the wye voltages (phase-neutral) or the delta voltages (phase-phase). The monitoring of the wye voltage is above all necessary to avoid earth-faults in a compensated or isolated network resulting in the tripping of the voltage protection.

! WARNING:
This parameter influences the protective functions.

Phase - phase The phase-phase voltage will be measured and all subsequent parameters concerning voltage monitoring "mains" are referred to this value (V_{L-L}).

Phase - neutral The phase-neutral voltage will be measured and all subsequent parameters concerning voltage monitoring "mains" are referred to this value (V_{L-N}).

EN	Mains settling time				
DE	Netzberuhigungszeit				
CL2	{0}	{1o}	{1oc}	{2oc}	
2801	✓	✓	✓	✓	

Breaker: Mains failure: Mains settling time

0 to 9999 s

To end the emergency operation, the monitored mains must be within the configured operating parameters without interruption for the minimum period of time set with this parameter without interruption. This parameter permits delaying the switching of the load from the generator to the mains. The display indicates "**Mains settling**" during this time.

Configure Monitoring: Mains, Operating Voltage / Frequency

Parameter Table

Level	Text	Setting range	Default value
Configure mains operating voltage / frequency			
	Upper voltage limit	100 to 150 %	110 %
	Hysteresis upper voltage limit	0 to 50 %	2 %
	Lower voltage limit	50 to 100 %	90 %
	Hysteresis lower voltage limit	0 to 50 %	2 %
	Upper frequency limit	100.0 to 150.0 %	110 %
	Hysteresis upper frequency limit	0.0 to 50.0 %	0.5 %
	Lower frequency limit	50.0 to 100.0 %	90 %
	Hysteresis lower frequency limit	0.0 to 50.0 %	0.5 %

Table 3-27: Monitoring - standard values - configure mains operating voltage / frequency

EN	Upper voltage limit				
DE	Obere Spannungsabw.				
CL2	{0}	{1o}	{1oc}	{2oc}	
5810	✓	✓	✓	✓	

Operating voltage window, mains, maximum limit

100 to 150 %

The maximum permissible positive deviation of the mains voltage from the mains rated voltage (parameter 1768 on page 40) is configured here. This value may be used as a voltage limit switch. The conditional state of this switch may be used as a command variable for the *LogicsManager* (02.09).

EN	Hysteresis upper voltage limit			
DE	Hyst. obere Spannungsabw.			
CL2	{0}	{1o}	{1oc}	{2oc}
5814	✓	✓	✓	✓

Operating voltage window, mains, maximum limit hysteresis **0 to 50 %**

If the mains voltage has exceeded the limit configured in parameter 5810, the voltage must fall below the limit and the value configured here, to be considered as being within the operating limits again.

EN	Lower voltage limit			
DE	Untere Spannungsabw.			
CL2	{0}	{1o}	{1oc}	{2oc}
5811	✓	✓	✓	✓

Operating voltage window, mains, minimum limit **50 to 100 %**

The maximum permissible negative deviation of the mains voltage from the mains rated voltage (parameter 1768 on page 40) is configured here. This value may be used as a voltage limit switch. The conditional state of this switch may be used as a command variable for the *LogicsManager* (02.09).

EN	Hysteresis lower voltage limit			
DE	Hyst. untere Spannungsabw.			
CL2	{0}	{1o}	{1oc}	{2oc}
5815	✓	✓	✓	✓

Operating voltage window, mains, minimum limit hysteresis **0 to 50 %**

If the mains voltage has fallen below the limit configured in parameter 5811, the voltage must exceed the limit and the value configured here, to be considered as being within the operating limits again.

EN	Upper frequency limit			
DE	Obere Frequenzabw.			
CL2	{0}	{1o}	{1oc}	{2oc}
5812	✓	✓	✓	✓

Operating frequency window, mains, maximum limit **100.0 to 150.0 %**

The maximum permissible positive deviation of the mains frequency from the rated system frequency (parameter 1750 on page 39) is configured here. This value may be used as a frequency limit switch. The conditional state of this switch may be used as a command variable for the *LogicsManager* (02.10).

EN	Hyst. upper frequency limit			
DE	Hyst. obere Frequenzabw.			
CL2	{0}	{1o}	{1oc}	{2oc}
5816	✓	✓	✓	✓

Operating frequency window, mains, maximum limit hysteresis **0.0 to 50.0 %**

If the mains frequency has exceeded the limit configured in parameter 5812, the frequency must fall below the limit and the value configured here, to be considered as being within the operating limits again.

EN	Lower frequency limit			
DE	Untere Frequenzabw.			
CL2	{0}	{1o}	{1oc}	{2oc}
5813	✓	✓	✓	✓

Operating frequency window, mains, minimum limit **50.0 to 100.0 %**

The maximum permissible negative deviation of the mains frequency from the rated system frequency (parameter 1750 on page 39) is configured here. This value may be used as a frequency limit switch. The conditional state of this switch may be used as a command variable for the *LogicsManager* (02.10).

EN	Hyst. lower frequency limit			
DE	Hyst. untere Frequenzabw.			
CL2	{0}	{1o}	{1oc}	{2oc}
5817	✓	✓	✓	✓

Operating frequency window, mains, minimum limit hysteresis **0.0 to 50.0 %**

If the mains frequency has fallen below the limit configured in parameter 5813, the frequency must exceed the limit and the value configured here, to be considered as being within the operating limits again.

Example:

If the mains rated voltage is 400 V, the upper voltage limit is 110 % (of the mains rated voltage, i.e. 440 V), and the hysteresis for the upper voltage limit is 5 % (of the mains rated voltage, i.e. 20 V), the mains voltage will be considered as being out of the operating limits as soon as it exceeds 440 V and will be considered as being within the operating limits again as soon as it falls below 420 V (440 V – 20 V).

If the rated system frequency is 50 Hz, the lower frequency limit is 90 % (of the rated system frequency, i.e. 45 Hz), and the hysteresis for the lower frequency limit is 5 % (of the rated system frequency, i.e. 2.5 Hz), the mains frequency will be considered as being out of the operating limits as soon as it falls below 45 Hz and will be considered as being within the operating limits again as soon as it exceeds 47.5 Hz (45 Hz + 2.5 Hz).



NOTE

The mains operating voltage/frequency parameters are used to trigger mains failure conditions and activate an emergency run. The mains values must be within this ranges to synchronize the mains circuit breaker. It is recommended to configure the operating limits within the monitoring limits.

Configure Monitoring: Mains, Decoupling

The mains decoupling function is intended for use in a mains parallel operation and monitors a series of subordinate mains protection thresholds. If a threshold is exceeded, the easYgen initiates a breaker opening and separates the generator(s) from the mains at the defined breaker.

The following thresholds are monitored:

- Overfrequency level 2 (refer to page 89 for detailed information)
- Underfrequency level 2 (refer to page 91 for detailed information)
- Overvoltage level 2 (refer to page 101 for detailed information)
- Undervoltage level 2 (refer to page 95 for detailed information)
- Mains phase shift (refer to page 97 for detailed information)

If one of these protective functions is triggered, the display indicates "**Mains decoupling**" (the logical command variable "07.25" will be enabled) and the active level 2 alarm.

Parameter table

Level	Text	Setting range	Default value
Mains decoupling			
	Mains decoupling	GCB / GCB->MCB / MCB / MCB->GCB / Off	GCB
	Mains decoupling feedback delay	0.10 to 5.00 s	0.4 s
	Alarm class	A/B/C/D/E/F	B
	Self acknowledgment	Yes / No	No

Table 3-28: Monitoring - standard values - mains decoupling

EN	Mains decoupling				
DE	Netzentkopplung				
CL2	{0}	{1o}	{1oc}	{2oc}	
3110	✓	✓	✓	✓	

Mains decoupling: Monitoring **GCB / GCB->MCB / MCB / MCB->GCB / Off**

- GCB**Mains decoupling is carried out according to the following parameters. If one of the subordinate monitoring functions is triggered, the GCB will be opened. If the unit is operated in parallel with the mains and the MCB opens, the GCB will be closed again.
- GCB->MCB**.Mains decoupling is carried out according to the following parameters. If one of the subordinate monitoring functions is triggered, the GCB will be opened. If the reply "GCB open" is not present within the delay configured in parameter 3113, the MCB will be opened as well.
- MCB**.....Mains decoupling is carried out according to the following parameters. If one of the subordinate monitoring functions is triggered, the MCB will be opened.
- MCB->GCB**.Mains decoupling is carried out according to the following parameters. If one of the subordinate monitoring functions is triggered, the MCB will be opened. If the reply "MCB open" is not present within the delay configured in parameter 3113, the GCB will be opened as well.
- Off**Mains decoupling monitoring is disabled.

EN	Mns. decoupling feedback delay				
DE	Netzentkopplg Rückmeldungszeit				
CL2	{0}	{1o}	{1oc}	{2oc}	
3113	✓	✓	✓	✓	

Mains decoupling: Feedback delay **0.10 to 5.00 s**

If the open signal from the respective circuit breaker cannot be detected within the time configured here, the mains decoupling function performs the action as configured in parameter 3110.

		Alarm class			
DE	EN	Alarmklasse			
CL2	{0}	{1o}	{1oc}	{2oc}	
3111	✓	✓	✓	✓	

Mains decoupling: Alarm class Class A/B/C/D/E/F

| [ⓘ See chapter "Alarm" on page 271.](#) |

Each limit may be assigned an independent alarm class that specifies what action should be taken when the limit is surpassed.

		Self acknowledge			
DE	EN	Selbstquittierend			
CL2	{0}	{1o}	{1oc}	{2oc}	
3112	✓	✓	✓	✓	

Mains decoupling: Self acknowledgment Yes / No

Yes.....The control automatically clears the alarm if the fault condition is no longer detected.

NoThe control does not automatically reset the alarm when the fault condition is no longer detected. The alarm must be acknowledged and reset by manually pressing the appropriate buttons or by activating the *LogicsManager* output "External acknowledgement" (via a discrete input or via an interface).



NOTE

The mains decoupling function is optimized on the both relay outputs "GCB open" and "MCB open". In case of using a free relay output in conjunction with the command variable 07.25 an additional delay time of up to 20ms is to consider.

Configure Monitoring: Mains, Overfrequency (Levels 1 & 2) ANSI# 810

There are two overfrequency alarm levels available in the control. Both alarms are definite time alarms and are illustrated in the figure below. The figure diagrams a frequency trend and the associated pickup times and length of the alarms. Monitoring of the frequency is accomplished in two steps.

If this protective function is triggered, the display indicates "Mains overfreq. 1" or "Mains overfreq. 2" and the logical command variable "07.06" or "07.07" will be enabled.

Refer to Appendix E: Triggering Characteristics, Figure 3-37 on page 324 for the triggering characteristic of this monitoring function.

Parameter table

The parameters represented in this table are specified in the following, whereas the description is identical for all limits; the limits may only differ in their setting ranges.

Level	Text	Setting range	Default value
Overfrequency (the hysteresis is 0.05 Hz.)			
Level 1	Monitoring	On / Off	On
	Limit	50.0 to 130.0 %	100.4 %
	Delay	0.02 to 99.99 s	0.06 s
	Alarm class	A/B/C/D/E/F	A
	Self acknowledgment	Yes / No	Yes
	Delayed by engine speed	Yes / No	No
Level 2	Monitoring	On / Off	On
	Limit	50.0 to 130.0 %	1020.0 %
	Delay	0.02 to 99.99 s	0.06 s
	Alarm class	A/B/C/D/E/F	B
	Self acknowledgment	Yes / No	Yes
	Delayed by engine speed	Yes / No	No

Table 3-29: Monitoring - standard values - mains overfrequency

EN	Monitoring				
DE	Überwachung				
	{0}	{1o}	{1oc}	{2oc}	
CL2	✓	✓	✓	✓	
2850					
2856					

Mains overfrequency: Monitoring (Limit 1/Limit 2) On / Off

On..... Overfrequency monitoring is carried out according to the following parameters. Monitoring is performed at two levels. Both values may be configured independent from each other (prerequisite: limit 1 < Level 2 limit).

Off..... Monitoring is disabled for limit 1 and/or Level 2 limit.

EN	Limit				
DE	Grenzwert				
	{0}	{1o}	{1oc}	{2oc}	
CL2	✓	✓	✓	✓	
2854					
2860					

Mains overfrequency: Threshold value (Limit 1/Limit 2) 50.0 to 130.0 %

① This value refers to the System rated frequency (parameter 1750on page 39).

The percentage values that are to be monitored for each threshold limit are defined here. If this value is reached or exceeded for at least the delay time without interruption, the action specified by the alarm class is initiated.

EN	Delay				
DE	Verzögerung				
	{0}	{1o}	{1oc}	{2oc}	
CL2	✓	✓	✓	✓	
2855					
2861					

Mains overfrequency: Delay (Limit 1/Limit 2) 0.02 to 99.99 s

If the monitored mains frequency value exceeds the threshold value for the delay time configured here, an alarm will be issued. If the monitored mains frequency falls below the threshold (minus the hysteresis) before the delay expires the time will be reset.

EN	Alarm class				
DE	Alarmklasse				
	{0}	{1o}	{1oc}	{2oc}	
CL2	✓	✓	✓	✓	
2851					
2857					

Mains overfrequency: Alarm class (Limit 1/Limit 2) Class A/B/C/D/E/F

① See chapter "Alarm" on page 271.

Each limit may be assigned an independent alarm class that specifies what action should be taken when the limit is surpassed.

		Self acknowledge			
		Selbstquittierend			
DE	EN				
CL2		{0}	{1o}	{1oc}	{2oc}
2852		✓	✓	✓	✓
2858					

Mains overfrequency: Self acknowledgment (Limit 1/Limit 2) Yes / No

Yes.....The control automatically clears the alarm if the fault condition is no longer detected.

No.....The control does not automatically reset the alarm when the fault condition is no longer detected. The alarm must be acknowledged and reset by manually pressing the appropriate buttons or by activating the *LogicsManager* output "External acknowledgement" (via a discrete input or via an interface).

		Delayed by engine speed			
		Verzögert durch Motordrehzahl			
DE	EN				
CL2		{0}	{1o}	{1oc}	{2oc}
2853		✓	✓	✓	✓
2859					

Mains overfrequency: Delayed engine speed (Level 1/Level 2) Yes / No

Yes.....Monitoring for fault conditions is not performed until engine delayed monitoring is enabled. The engine monitoring delay time (parameter 3315 on page 186) must expire prior to fault monitoring being enabled for parameters assigned this delay.

No.....Monitoring for this fault condition is continuously enabled regardless of engine speed.



NOTE

The mains overfrequency Level 2 limit configuration parameters are located below the mains decoupling function menu on the display.

Configure Monitoring: Mains, Underfrequency (Levels 1 & 2) ANSI# 81U

There are two underfrequency alarm levels available in the control. Both alarms are definite time alarms and are illustrated in the figure below. The figure diagrams a frequency trend and the associated pickup times and length of the alarms. Monitoring of the frequency is performed in two steps.

If this protective function is triggered, the display indicates "**Mains underfreq. 1**" or "**Mains underfreq. 2**" and the logical command variable "07.08" or "07.09" will be enabled.

Refer to Appendix E: Triggering Characteristics, Figure 3-38 on page 325 for the triggering characteristic of this monitoring function.

Parameter table

The parameter limits represented in this table have identical permissible ranges. Each parameter may be configured with different settings to create unique trip characteristics for specific thresholds.

Level	Text	Setting range	Default value
Underfrequency (the hysteresis is 0.05 Hz.)			
Level 1	Monitoring	On / Off	On
	Limit	50.0 to 130.0 %	99.6 %
	Delay	0.02 to 99.99 s	1.50 s
	Alarm class	A/B/C/D/E/F	A
	Self acknowledgment	Yes / No	Yes
	Delayed by engine speed	Yes / No	No
Level 2	Monitoring	On / Off	On
	Limit	50.0 to 130.0 %	98.0 %
	Delay	0.02 to 99.99 s	0.06 s
	Alarm class	A/B/C/D/E/F	B
	Self acknowledgment	Yes / No	Yes
	Delayed by engine speed	Yes / No	No

Table 3-30: Monitoring - standard values - mains underfrequency

EN	Monitoring				
DE	Überwachung				
CL2	{0}	{1o}	{1oc}	{2oc}	
2900	✓	✓	✓	✓	
2906					

Mains underfrequency: Monitoring (Level 1/Level 2) On / Off

On..... Underfrequency monitoring is carried out according to the following parameters. Monitoring is performed at two levels. Both values may be configured independent from each other (prerequisite: Level 1 > Level 2).

Off..... Monitoring is disabled for limit 1 and/or Level 2 limit.

EN	Limit				
DE	Grenzwert				
CL2	{0}	{1o}	{1oc}	{2oc}	
2904	✓	✓	✓	✓	
2910					

Mains underfrequency: Threshold value (Level 1/Level 2) 50.0 to 130.0 %

ⓘ This value refers to the System rated frequency (parameter 1750on page 39).

The percentage values that are to be monitored for each threshold limit are defined here. If this value is reached or fallen below for at least the delay time without interruption, the action specified by the alarm class is initiated.

EN	Delay				
DE	Verzögerung				
CL2	{0}	{1o}	{1oc}	{2oc}	
2905	✓	✓	✓	✓	
2911					

Mains underfrequency: Delay (Level 1/Level 2) 0.02 to 99.99 s

If the monitored mains frequency value falls below the threshold value for the delay time configured here, an alarm will be issued. If the monitored mains frequency exceeds the threshold (plus the hysteresis) again before the delay expires the time will be reset.

EN	Alarm class				
DE	Alarmklasse				
CL2	{0}	{1o}	{1oc}	{2oc}	
2901	✓	✓	✓	✓	
2907					

Mains underfrequency: Alarm class (Level 1/Level 2) Class A/B/C/D/E/F

ⓘ See chapter "Alarm" on page 271.

Each limit may be assigned an independent alarm class that specifies what action should be taken when the limit is surpassed.

DE	EN	Self acknowledge			
DE	EN	Selbstquittierend			
CL2		{0}	{1o}	{1oc}	{2oc}
2902		✓	✓	✓	✓
2908					

Mains underfrequency: Self acknowledgment (Level 1/Level 2) **Yes / No**

Yes.....The control automatically clears the alarm if the fault condition is no longer detected.

No.....The control does not automatically reset the alarm when the fault condition is no longer detected. The alarm must be acknowledged and reset by manually pressing the appropriate buttons or by activating the *LogicsManager* output "External acknowledgement" (via a discrete input or via an interface).

DE	EN	Delayed by engine speed			
DE	EN	Verzögert durch Motordrehzahl			
CL2		{0}	{1o}	{1oc}	{2oc}
2903		✓	✓	✓	✓
2909					

Mains underfrequency Engine delayed monitoring (Level 1/Level 2) **Yes / No**

Yes.....Monitoring for fault conditions is not performed until engine delayed monitoring is enabled. The engine monitoring delay time (parameter 3315 on page 186) must expire prior to fault monitoring being enabled for parameters assigned this delay.

No.....Monitoring for this fault condition is continuously enabled regardless of engine speed.



NOTE

The mains underfrequency Level 2 limit configuration parameters are located below the mains decoupling function menu on the display.

Configure Monitoring: Mains, Overvoltage (Levels 1 & 2) ANSI# 59

Voltage is monitored depending on parameter "Mains voltage measuring" (parameter 1853 on page 43). There are two overvoltage alarm levels available in the control. Both alarms are definite time alarms and are illustrated in the figure below. The figure diagrams a frequency trend and the associated pickup times and length of the alarms. Monitoring of the voltage is done in two steps.

If this protective function is triggered, the display indicates "Mains overvoltage 1" or "Mains overvoltage 2" and the logical command variable "07.10" or "07.11" will be enabled.

Refer to Appendix E: Triggering Characteristics, Figure 3-37 on page 324 for the triggering characteristic of this monitoring function.

Parameter table

The parameter limits represented in this table have identical permissible ranges. Each parameter may be configured with different settings to create unique trip characteristics for specific thresholds.

Level	Text	Setting range	Default value
Overvoltage (the hysteresis is 0.7 % of the rated value)			
Level 1	Monitoring	On / Off	On
	Limit	50.0 to 125.0 %	108.0 %
	Delay	0.02 to 99.99 s	1.50 s
	Alarm class	A/B/C/D/E/F	A
	Self acknowledgment	Yes / No	Yes
Level 2	Monitoring	On / Off	On
	Limit	50.0 to 125.0 %	110.0 %
	Delay	0.02 to 99.99 s	0.06 s
	Alarm class	A/B/C/D/E/F	B
	Delayed by engine speed	Yes / No	No

Table 3-31: Monitoring - standard values - mains overvoltage

EN	Monitoring				
DE	Überwachung				
CL2	{0}	{1o}	{1oc}	{2oc}	
2950	✓	✓	✓	✓	
2956					

Mains overvoltage: Monitoring (Level 1/Level 2) On / Off

On..... Overvoltage monitoring is carried out according to the following parameters. Monitoring is performed at two levels. Both values may be configured independent from each other (prerequisite: limit 1 < Level 2 limit).

Off..... Monitoring is disabled for limit 1 and/or Level 2 limit.

EN	Limit				
DE	Grenzwert				
CL2	{0}	{1o}	{1oc}	{2oc}	
2954	✓	✓	✓	✓	
2960					

Mains overvoltage: Threshold value (Level 1/Level 2) 50.0 to 125.0 %

ⓘ This value refers to the Mains rated voltage (parameter 1768 on page 40).

The percentage values that are to be monitored for each threshold limit are defined here. If this value is reached or exceeded for at least the delay time without interruption, the action specified by the alarm class is initiated.

EN	Delay				
DE	Verzögerung				
CL2	{0}	{1o}	{1oc}	{2oc}	
2955	✓	✓	✓	✓	
2961					

Mains overvoltage: Delay (Level 1/Level 2) 0.02 to 99.99 s

If the monitored mains voltage exceeds the threshold value for the delay time configured here, an alarm will be issued. If the monitored mains voltage falls below the threshold (minus the hysteresis) before the delay expires the time will be reset.

EN	Alarm class				
DE	Alarmklasse				
CL2	{0}	{1o}	{1oc}	{2oc}	
2951	✓	✓	✓	✓	
2957					

Mains overvoltage: Alarm class (Level 1/Level 2) Class A/B/C/D/E/F

ⓘ See chapter "Alarm" on page 271.

Each limit may be assigned an independent alarm class that specifies what action should be taken when the limit is surpassed.

DE	EN	Self acknowledge			
DE	EN	Selbstquittierend			
CL2		{0}	{1o}	{1oc}	{2oc}
2952		✓	✓	✓	✓
2958					

Mains overvoltage: Self acknowledgment (Level 1/Level 2) Yes / No

Yes.....The control automatically clears the alarm if the fault condition is no longer detected.

No.....The control does not automatically reset the alarm when the fault condition is no longer detected. The alarm must be acknowledged and reset by manually pressing the appropriate buttons or by activating the *LogicsManager* output "External acknowledgement" (via a discrete input or via an interface).

DE	EN	Delayed by engine speed			
DE	EN	Verzögert durch Motordrehzahl			
CL2		{0}	{1o}	{1oc}	{2oc}
2953		---	✓	✓	✓
2959					

Mains overvoltage: Engine delayed monitoring (Level 1/Level 2) Yes / No

Yes.....Monitoring for fault conditions is not performed until engine delayed monitoring is enabled. The engine monitoring delay time (parameter 3315 on page 186) must expire prior to fault monitoring being enabled for parameters assigned this delay.

No.....Monitoring for this fault condition is continuously enabled regardless of engine speed.



NOTE

The mains overvoltage Level 2 limit configuration parameters are located below the mains decoupling function menu on the display.

Configure Monitoring: Mains, Undervoltage (Levels 1 & 2) ANSI# 27

Voltage is monitored depending on parameter "Mains voltage measuring" (parameter 1853 on page 43). There are two undervoltage alarm levels available in the control. Both alarms are definite time alarms and are illustrated in the figure below. The figure diagrams a frequency trend and the associated pickup times and length of the alarms. Monitoring of the voltage is done in two steps.

If this protective function is triggered, the display indicates "Mains undervoltage 1" or "Mains undervoltage 2" and the logical command variable "07.12" or "07.13" will be enabled.

Refer to Appendix E: Triggering Characteristics, Figure 3-38 on page 325 for the triggering characteristic of this monitoring function.

Parameter table

The parameter limits represented in this table have identical permissible ranges. Each parameter may be configured with different settings to create unique trip characteristics for specific thresholds.

Level	Text	Setting range	Default value
Undervoltage (the hysteresis is 0.7 % of the rated value)			
Level 1	Monitoring	On / Off	On
	Limit	50.0 to 125.0 %	92.0 %
	Delay	0.02 to 99.99 s	1.50 s
	Alarm class	A/B/C/D/E/F	A
	Self acknowledgment	Yes / No	Yes
Level 2	Monitoring	On / Off	On
	Limit	50.0 to 125.0 %	90.0 %
	Delay	0.02 to 99.99 s	0.06 s
	Alarm class	A/B/C/D/E/F	B
	Delayed by engine speed	Yes / No	No

Table 3-32: Monitoring - standard values - mains undervoltage

EN	Monitoring			
DE	Überwachung			
CL2	{0}	{1o}	{1oc}	{2oc}
3000	✓	✓	✓	✓
3006				

Mains undervoltage: Monitoring (Level 1/Level 2) On / Off

On..... Undervoltage monitoring is carried out according to the following parameters. Monitoring is performed at two levels. Both values may be configured independent from each other (prerequisite: Level 1 limit < Level 2 limit).

Off..... Monitoring is disabled for Level 1 limit and/or Level 2 limit.

EN	Limit			
DE	Grenzwert			
CL2	{0}	{1o}	{1oc}	{2oc}
3004	✓	✓	✓	✓
3010				

Mains undervoltage: Threshold value (Level 1/Level 2) 50.0 to 125.0 %

ⓘ This value refers to the Mains rated voltage (parameter 1768 on page 40).

The percentage values that are to be monitored for each threshold limit are defined here. If this value is reached or fallen below for at least the delay time without interruption, the action specified by the alarm class is initiated.

EN	Delay			
DE	Verzögerung			
CL2	{0}	{1o}	{1oc}	{2oc}
3005	✓	✓	✓	✓
3011				

Mains undervoltage: Delay (Level 1/Level 2) 0.02 to 99.99 s

If the monitored mains voltage falls below the threshold value for the delay time configured here, an alarm will be issued. If the monitored mains voltage exceeds the threshold (plus the hysteresis) again before the delay expires the time will be reset.

EN	Alarm class			
DE	Alarmklasse			
CL2	{0}	{1o}	{1oc}	{2oc}
3001	✓	✓	✓	✓
3007				

Mains undervoltage: Alarm class (Level 1/Level 2) Class A/B/C/D/E/F

ⓘ See chapter "Alarm" on page 271.

Each limit may be assigned an independent alarm class that specifies what action should be taken when the limit is surpassed.

DE	EN	Self acknowledge			
DE	EN	Selbstquittierend			
CL2		{0}	{1o}	{1oc}	{2oc}
3002		✓	✓	✓	✓
3008					

Mains undervoltage: Self acknowledgment (Level 1/Level 2) Yes / No

Yes.....The control automatically clears the alarm if the fault condition is no longer detected.

No.....The control does not automatically reset the alarm when the fault condition is no longer detected. The alarm must be acknowledged and reset by manually pressing the appropriate buttons or by activating the *LogicsManager* output "External acknowledgement" (via a discrete input or via an interface).

DE	EN	Delayed by engine speed			
DE	EN	Verzögert durch Motordrehzahl			
CL2		{0}	{1o}	{1oc}	{2oc}
3003		✓	✓	✓	✓
3009					

Mains undervoltage: Delayed engine speed (Level 1/Level 2) Yes / No

Yes.....Monitoring for fault conditions is not performed until engine delayed monitoring is enabled. The engine monitoring delay time (parameter 3315 on page 186) must expire prior to fault monitoring being enabled for parameters assigned this delay.

No.....Monitoring for this fault condition is continuously enabled regardless of engine speed.



NOTE

The mains undervoltage Level 2 limit configuration parameters are located below the mains decoupling function menu on the display.

Configure Monitoring: Mains, Phase Shift

A vector/phase shift is defined as the sudden variation of the voltage curve which may be caused by a major generator load change. It usually occurs, if the utility opens the MCB, which causes a load change for the genset.

The easYgen measures the duration of a cycle, where a new measurement is started with each voltage passing through zero. The measured cycle duration will be compared with an internal quartz-calibrated reference time to determine the cycle duration difference of the voltage signal. A vector/phase shift as shown in Figure 3-11 causes a premature or delayed zero passage. The determined cycle duration difference corresponds with the occurring phase shift angle.

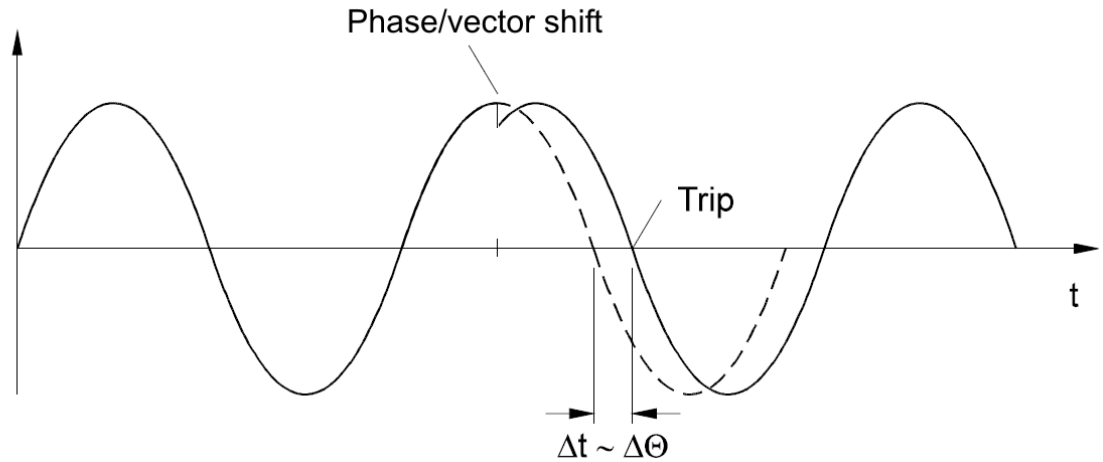

Figure 3-11: Monitoring - phase shift

The monitoring may be carried out three-phased or one/three-phased. Different limits may be configured for one-phase and three-phase monitoring. The vector/phase shift monitor can also be used as an additional method to decouple from the mains. Vector/phase shift monitoring is only enabled after the monitored voltage exceeds 50% of the PT secondary rated voltage.

Function: "Voltage cycle duration not within the permissible range" - The voltage cycle duration exceeds the configured limit value for the phase/vector shift. The result is, that the power circuit breaker that disconnects from the mains, is opened, the message "**Mains phase shift**" is displayed, and the logical command variable "07.14" is enabled. The prerequisite for phase/vector shift monitoring is that the generator is operating in a mains parallel operation (the MCB and GCB are both closed).

Parameter table

Level	Text	Setting range	Default value
Mains phase shift			
	Monitoring	On / Off	On
	Monitoring	1- and 3 phase / 3 phase	1- and 3 phase
	Limit 1 phae	3 to 30 °	20 °
	Limit 3 phase	3 to 30 °	8 °
	Alarm class	A/B/C/D/E/F	B
	Self acknowledgment	Yes / No	Yes
	Delayed by engine speed	Yes / No	No

Table 3-33: Monitoring - standard values - mains phase shift

		Monitoring			
		Überwachung			
CL2	{0}	{1o}	{1oc}	{2oc}	
3050	✓	✓	✓	✓	

Mains phase shift: Monitoring On / Off

On.....Phase shift monitoring is carried out according to the following parameters.
OffMonitoring is disabled.

		Monitoring			
		Überwachung auf			
CL2	{0}	{1o}	{1oc}	{2oc}	
3053	✓	✓	✓	✓	

Mains phase shift: Monitoring 1- and 3 phase / 3 phase

1- and 3 phase During single-phase voltage phase/vector shift monitoring, tripping occurs if the phase/vector shift exceeds the configured threshold value (parameter 3054) in at least one of the three phases. Note: If a phase/vector shift occurs in one or two phases, the single-phase threshold value (parameter 3054) is taken into consideration; if a phase/vector shift occurs in all three phases, the three-phase threshold value (parameter 3055) is taken into consideration. Single phase monitoring is very sensitive and may lead to nuisance tripping if the selected phase angle settings are too small.
3 phaseDuring three-phase voltage phase/vector shift monitoring, tripping occurs only if the phase/vector shift exceeds the specified threshold value (parameter 3055) in all three phases within 2 cycles.



NOTE

3 phase mains phase shift monitoring is only enabled if Mains voltage measuring (parameter 1853) is configured to "3Ph 4W" or "3Ph 3W".

		Limit 1 phase			
		Grenzwert 1-phasig			
CL2	{0}	{1o}	{1oc}	{2oc}	
3054	✓	✓	✓	✓	

Mains phase shift: Threshold value 1 phase 3 to 30 °

If the electrical angle of the mains voltage shifts more than this configured value in any single phase, an alarm with the class configured in parameter 3051 is initiated. Depending on the configured mains decoupling procedure (parameter 3110 on page 87), the GCB, MCB, or an external CB will be opened.

		Limit 3 phase			
		Grenzwert 3-phasig			
CL2	{0}	{1o}	{1oc}	{2oc}	
3055	✓	✓	✓	✓	

Mains phase shift: Threshold value 3 phase 3 to 30 °

If the electrical angle of the mains voltage shifts more than this configured value in all three phases, an alarm with the class configured in parameter 3051 is initiated. Depending on the configured mains decoupling procedure (parameter 3110 on page 87), the GCB, MCB, or an external CB will be opened.

		Alarm class			
		Alarmklasse			
CL2	{0}	{1o}	{1oc}	{2oc}	
3051	✓	✓	✓	✓	

Mains phase shift: Alarm class Class A/B/C/D/E/F

| ⓘ See chapter "Alarm" on page 271. |

Each limit may be assigned an independent alarm class that specifies what action should be taken when the limit is surpassed.

EN	Self acknowledge				
DE	Selbstquittierend				
CL2	{0}	{1o}	{1oc}	{2oc}	
3052	✓	✓	✓	✓	

Mains phase shift: Self acknowledgment

Yes / No

Yes The control automatically clears the alarm if the fault condition is no longer detected.

No..... The control does not automatically reset the alarm when the fault condition is no longer detected. The alarm must be acknowledged and reset by manually pressing the appropriate buttons or by activating the *LogicsManager* output "External acknowledgement" (via a discrete input or via an interface).

EN	Delayed by engine speed				
DE	Verzögert durch Motordrehzahl				
CL2	{0}	{1o}	{1oc}	{2oc}	
3056	✓	✓	✓	✓	

Mains phase shift: Delayed engine speed

Yes / No

Yes Monitoring for fault conditions is not performed until engine delayed monitoring is enabled. The engine monitoring delay time (parameter 3315 on page 186) must expire prior to fault monitoring being enabled for parameters assigned this delay.

No..... Monitoring for this fault condition is continuously enabled regardless of engine speed.



NOTE

The mains phase shift configuration parameters are located below the mains decoupling function menu on the display.

Configure Monitoring: Mains, Voltage Phase Rotation - {2oc}



CAUTION

Please ensure during installation that all voltages applied to this unit are wired correctly to both sides of the circuit breaker. Failure to do so may result in damage to the control unit and/or generation equipment due to closing the breaker asynchronous or with mismatched phase rotations and phase rotation monitoring enabled at all connected components (engine, generator, breakers, cable, busbars, etc.).

This function may block a connection of systems with mismatched phases systems only under the following conditions:

- The voltages being measured are wired correctly with respect to the phase rotation at the measuring points (i.e. the voltage transformer in front and behind the circuit breaker)
- The measuring voltages are wired without angular phase shift or interruption from the measuring point to the control unit
- The measuring voltages are wired to the correct terminals of the control unit (i.e. L1 of the generator is connected with the terminal of the control unit which is intended for the L1 of the generator)
- The *LogicsManager* function "Enable MCB" (refer to parameter 12923 on page 157) is false in case of a incorrect rotation field

Correct phase rotation of the phase voltages ensures that damage will not occur during a breaker closure to either the mains or the generator. The voltage phase rotation alarm checks the phase rotation of the voltages and the configured phase rotation to ensure they are identical. The directions of rotation are differentiated as "clockwise" and "counter clockwise". With a clockwise field the direction of rotation is "L1-L2-L3"; with a counter clockwise field the direction of rotation is "L1-L3-L2". If the control is configured for a clockwise rotation and the voltages into the unit are calculated as counterclockwise the alarm will be initiated. The direction of configured rotation being monitored by the control unit is displayed on the screen.

If this protective function is triggered, the display indicates "**Mns.ph.rot. mismatch**" and the logical command variable "07.05" will be enabled.

Parameter table

Level	Text	Setting range	Default value
Mains voltage phase direction fault (the hysteresis is 0.7 % of the rated value)			
	Monitoring	On / Off	On
	Mains phase rotation	CW / CCW	CW
	Alarm class	A/B	B
	Self acknowledgment	Yes / No	No
	Delayed by engine speed	Yes / No	No

Table 3-34: Monitoring - standard values - mains voltage phase rotation



NOTE

This monitoring function is only enabled if Mains voltage measuring (parameter 1853) is configured to "3Ph 4W" or "3Ph 3W" and the measured voltage exceeds 50 % of the rated voltage (parameter 1768) or if Mains voltage measuring (parameter 1853) is configured to "1Ph 2W" (in this case, the phase rotation is not evaluated, but defined by the 1Ph2W phase rotation (parameter 1859)).

EN	Monitoring			
DE	Überwachung			
CL2 3970	{0}	{1o}	{1oc}	{2oc}
	✓	✓	✓	✓

Mains voltage phase rotation: Monitoring On / Off

On Phase rotation monitoring is carried out according to the following parameters
Off No monitoring is carried out.

EN	Mains phase rotation			
DE	Netzdrehfeld			
CL2 3974	{0}	{1o}	{1oc}	{2oc}
	✓	✓	✓	✓

Mains voltage phase rotation: Direction CW / CCW

CW The three-phase measured mains voltage is rotating CW (clock-wise; that means the voltage rotates in L1-L2-L3 direction; standard setting).
CCW The three-phase measured mains voltage is rotating CCW (counter clock-wise; that means the voltage rotates in L1-L3-L2 direction).

EN	Alarm class			
DE	Alarmklasse			
CL2 3971	{0}	{1o}	{1oc}	{2oc}
	✓	✓	✓	✓

Mains voltage phase rotation: Alarm class Class A/B/C/D/E/F

→ CAUTION:
 If an alarm class that leads to an engine shutdown (alarm class C or higher) is configured into this parameter, a main phase rotation alarm may lead to a genset shutdown due to an alarm of class C or higher.

① See chapter "Alarm" on page 271.

Each limit may be assigned an independent alarm class that specifies what action should be taken when the limit is surpassed.

EN	Self acknowledge			
DE	Selbstquittierend			
CL2 3972	{0}	{1o}	{1oc}	{2oc}
	✓	✓	✓	✓

Mains voltage phase rotation: Self acknowledgment Yes / No

Yes The control automatically clears the alarm if the fault condition is no longer detected.
No The control does not automatically reset the alarm when the fault condition is no longer detected. The alarm must be acknowledged and reset by manually pressing the appropriate buttons or by activating the *LogicsManager* output "External acknowledgement" (via a discrete input or via an interface).

EN	Delayed by engine speed			
DE	Verzögert durch Motordrehzahl			
CL2 3973	{0}	{1o}	{1oc}	{2oc}
	✓	✓	✓	✓

Mains voltage phase rotation: Engine delayed monitoring Yes / No

Yes Monitoring for fault conditions is not performed until engine delayed monitoring is enabled. The engine monitoring delay time (parameter 3315 on page 186) must expire prior to fault monitoring being enabled for parameters assigned this delay.
No Monitoring for this fault condition is continuously enabled regardless of engine speed.

Configure Monitoring: Engine

Configure Monitoring: Engine, Overspeed (Levels 1 & 2) ANSI# 12

The speed measured by the magnetic pickup unit (MPU) is monitored for overspeed. If the MPU is disabled, the speed may only be monitored using the generator overfrequency monitoring. If the MPU speed exceeds the overspeed limits the configured alarms will be initiated.

If this protective function is triggered, the display indicates "Overspeed 1" or "Overspeed 2" and the logical command variable "05.01" or "05.02" will be enabled.

Refer to Appendix E: Triggering Characteristics, Figure 3-37 on page 324 for the triggering characteristic of this monitoring function.

Parameter table

The parameter limits represented in this table have identical permissible ranges. Each parameter may be configured with different settings to create unique trip characteristics for specific thresholds.

Level	Text	Setting range	Default value
Engine overspeed (the hysteresis is 50 min ⁻¹).			
Level 1	Monitoring	On / Off	On
	Limit	0 to 9,999 RPM	1,850 RPM
	Delay	0.02 to 99.99 s	1.00 s
	Alarm class	A/B/C/D/E/F	B
	Self acknowledgment	Yes / No	No
	Delayed by engine speed	Yes / No	No
Level 2	Monitoring	On / Off	On
	Limit	0 to 9,999 RPM	1,900 RPM
	Delay	0.02 to 99.99 s	0.10 s
	Alarm class	A/B/C/D/E/F	F
	Self acknowledgment	Yes / No	No
	Delayed by engine speed	Yes / No	No

Table 3-35: Monitoring - standard values - engine overspeed

EN	Monitoring
DE	Überwachung
CL2	{0} {1o} {1oc} {2oc}
2100	✓ ✓ ✓ ✓
2106	

Engine overspeed: Monitoring (Level 1/Level 2) On / Off

On Overspeed monitoring is carried out according to the following parameters. Monitoring is performed at two levels. Both values may be configured independent from each other (prerequisite: Level 1 > Level 2).

Off Monitoring is disabled for Level 1 limit and/or Level 2 limit.

EN	Limit
DE	Grenzwert
CL2	{0} {1o} {1oc} {2oc}
2104	✓ ✓ ✓ ✓
2110	

Engine overspeed: Threshold value (Level 1/Level 2) 0 to 9,999 RPM

The threshold values that are to be monitored are defined here. If the monitored engine speed reaches or exceeds this value for at least the delay time without interruption, the action specified by the alarm class is initiated.

EN	Delay
DE	Verzögerung
CL2	{0} {1o} {1oc} {2oc}
2105	✓ ✓ ✓ ✓
2111	

Engine overspeed: Delay (Level 1/Level 2) 0.02 to 99.99 s

If the monitored engine speed exceeds the threshold value for the delay time configured here, an alarm will be issued. If the monitored engine speed falls below the threshold (minus the hysteresis) before the delay expires the time will be reset.

EN	Alarm class
DE	Alarmlasse
CL2	{0} {1o} {1oc} {2oc}
2101	✓ ✓ ✓ ✓
2107	

Engine overspeed: Alarm class (Level 1/Level 2) Class A/B/C/D/E/F

① See chapter "Alarm" on page 271.

Each limit may be assigned an independent alarm class that specifies what action should be taken when the limit is surpassed.

EN	Self acknowledge				
DE	Selbstquittierend				
CL2	{0}	{1o}	{1oc}	{2oc}	
2102	✓	✓	✓	✓	
2108					

Engine overspeed: Self acknowledgment (Level 1/Level 2) Yes / No

Yes The control automatically clears the alarm if the fault condition is no longer detected.

No..... The control does not automatically reset the alarm when the fault condition is no longer detected. The alarm must be acknowledged and reset by manually pressing the appropriate buttons or by activating the *LogicsManager* output "External acknowledgement" (via a discrete input or via an interface).

EN	Delayed by engine speed				
DE	Verzögert durch Motordrehzahl				
CL2	{0}	{1o}	{1oc}	{2oc}	
2103	✓	✓	✓	✓	
2109					

Engine overspeed: Engine delayed monitoring (Level 1/Level 2) Yes / No

Yes Monitoring for fault conditions is not performed until engine delayed monitoring is enabled. The engine monitoring delay time (parameter 3315 on page 186) must expire prior to fault monitoring being enabled for parameters assigned this delay.

No..... Monitoring for this fault condition is continuously enabled regardless of engine speed.

Configure Monitoring: Engine, Underspeed (Levels 1 & 2)

The speed measured by the magnetic pickup unit (MPU) is monitored for underspeed. If the MPU is disabled, the speed may only be monitored using the generator underfrequency monitoring. If the MPU speed falls below the underspeed limits the configured alarms will be initiated.

If this protective function is triggered, the display indicates "**Underspeed 1**" or "**Underspeed 2**" and the logical command variable "05.03" or "05.04" will be enabled.

Refer to Appendix E: Triggering Characteristics, Figure 3-38 on page 325 for the triggering characteristic of this monitoring function.

Parameter table

The parameter limits represented in this table have identical permissible ranges. Each parameter may be configured with different settings to create unique trip characteristics for specific thresholds.

Level	Text	Setting range	Default value
Engine underspeed (the hysteresis is 50 min ⁻¹)			
Level 1	Monitoring	On / Off	On
	Limit	0 to 9,999 RPM	1,300 RPM
	Delay	0.02 to 99.99 s	1.00 s
	Alarm class	A/B/C/D/E/F	B
	Self acknowledgment	Yes / No	No
	Delayed by engine speed	Yes / No	Yes
Level 2	Monitoring	On / Off	On
	Limit	0 to 9,999 RPM	1,250 RPM
	Delay	0.02 to 99.99 s	0.10 s
	Alarm class	A/B/C/D/E/F	F
	Self acknowledgment	Yes / No	No
	Delayed by engine speed	Yes / No	Yes

Table 3-36: Monitoring - standard values - engine underspeed

EN	Monitoring
DE	Überwachung
CL2	{0} {1o} {1oc} {2oc}
2150	✓ ✓ ✓ ✓
2156	

Engine underspeed: Monitoring (Level 1/Level 2) On / Off

On Underspeed monitoring is carried out according to the following parameters. Monitoring is performed at two levels. Both values may be configured independent from each other (prerequisite: Level 1 > Level 2).

Off Monitoring is disabled for Level 1 limit and/or Level 2 limit.

EN	Limit
DE	Grenzwert
CL2	{0} {1o} {1oc} {2oc}
2154	✓ ✓ ✓ ✓
2160	

Engine underspeed: Threshold value (Level 1/Level 2) 0 to 9,999 RPM

The threshold values that are to be monitored are defined here. If the monitored engine speed reaches or falls below this value for at least the delay time without interruption, the action specified by the alarm class is initiated.

EN	Delay
DE	Verzögerung
CL2	{0} {1o} {1oc} {2oc}
2155	✓ ✓ ✓ ✓
2161	

Engine underspeed: Delay (Level 1/Level 2) 0.02 to 99.99 s

If the monitored engine speed falls below the threshold value for the delay time configured here, an alarm will be issued. If the monitored engine speed exceeds the threshold (plus the hysteresis) again before the delay expires the time will be reset.

EN	Alarm class
DE	Alarmlasse
CL2	{0} {1o} {1oc} {2oc}
2151	✓ ✓ ✓ ✓
2157	

Engine underspeed: Alarm class (Level 1/Level 2) Class A/B/C/D/E/F

! See chapter "Alarm" on page 271.

Each limit may be assigned an independent alarm class that specifies what action should be taken when the limit is surpassed.

EN	Self acknowledge				
DE	Selbstquittierend				
CL2	{0}	{1o}	{1oc}	{2oc}	
2152	✓	✓	✓	✓	
2158					

Engine underspeed: Self acknowledgment (Level 1/Level 2) Yes / No

Yes The control automatically clears the alarm if the fault condition is no longer detected.

No The control does not automatically reset the alarm when the fault condition is no longer detected. The alarm must be acknowledged and reset by manually pressing the appropriate buttons or by activating the *LogicsManager* output "External acknowledgement" (via a discrete input or via an interface).

EN	Delayed by engine speed				
DE	Verzögert durch Motordrehzahl				
CL2	{0}	{1o}	{1oc}	{2oc}	
2153	✓	✓	✓	✓	
2159					

Engine underspeed: Engine delayed monitoring (Level 1/Level 2) Yes / No

Yes Monitoring for fault conditions is not performed until engine delayed monitoring is enabled. The engine monitoring delay time (parameter 3315 on page 186) must expire prior to fault monitoring being enabled for parameters assigned this delay.

No Monitoring for this fault condition is continuously enabled regardless of engine speed.

Configure Monitoring: Engine/Generator, Speed Detection (Speed/Frequency Mismatch)

Speed detection checks if the generator voltage frequency f (determined from the measured generator voltage) differs from the measured engine speed n (determined from the Pickup signal) and determines a difference $(\Delta f-n)$. If the two frequencies are not identical $(\Delta f-n \neq 0)$ and the monitored frequency mismatch reaches or exceeds the threshold, an alarm is output. Additionally the *LogicsManager* output "Firing speed" is checked upon its logical status with respect to the measuring values "generator frequency" and "Pickup speed". If this protective function is triggered, the display indicates "Speed/freq. mismatch" and the logical command variable "05.07" will be enabled.



NOTE

Speed/frequency mismatch (n/f mismatch) is carried out only if an MPU is connected to the control and parameter "Speed pickup" (parameter 1600 on page 189), is configured On. The following is valid:

- The measurement via **Pickup is enabled** (On):
 - ⇒ Mismatch monitoring is carried out using the engine speed from the Pickup and the generator frequency. If the speed/frequency mismatch or the *LogicsManager* is enabled and the frequency is outside of the configured limit, an alarm will be issued.
- The measurement via **Pickup is disabled** (Off):
 - ⇒ Mismatch monitoring is carried out using the generator frequency and the *LogicsManager*. If the *LogicsManager* output is enabled and the frequency is outside of the configured limit, an alarm will be issued.

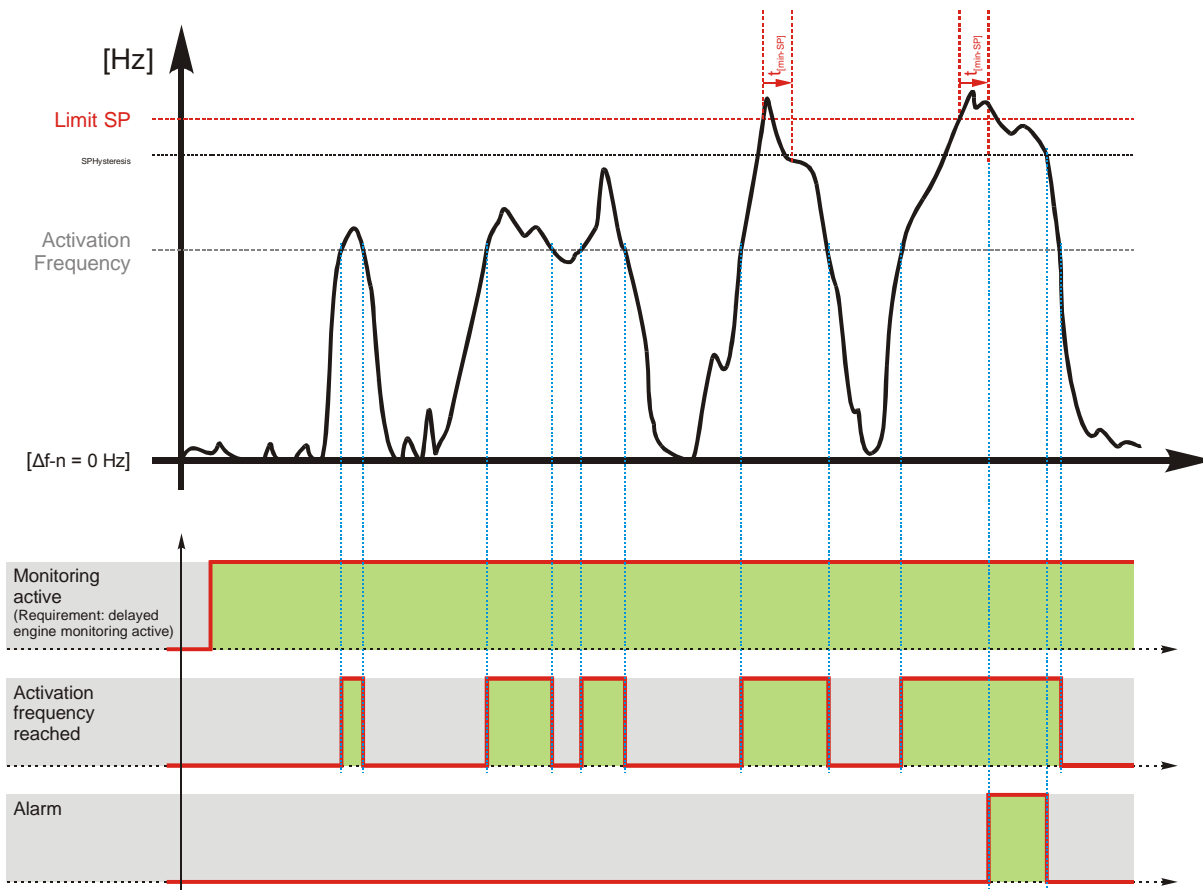

Figure 3-12: Monitoring - plausibility check n/f

Parameter table

Level	Text	Setting range	Default value
Speed detection (speed/frequency mismatch) (the hysteresis is 50 RPM).			
	Monitoring	On / Off	On
	Speed/frequency mismatch limit	1.5 to 8.5 Hz	5.0 Hz
	Delay	0.02 to 99.99 s	2.00 s
	Activation frequency	15 to 85 Hz	20 Hz
	Alarm class	A/B/C/D/E/F	E
	Self acknowledgment	Yes / No	No

Table 3-37: Monitoring - standard values - plausibility control n/f

EN	Monitoring			
DE	Überwachung			
CL2	{0}	{1o}	{1oc}	{2oc}
2450	✓	✓	✓	✓

n/f/LogicsManager mismatch: Monitoring **On / Off**

On.....Monitoring of the speed/frequency/*LogicsManager* mismatch (n/f/*LM* mismatch) is carried out according to the following parameters.
Off.....Monitoring is disabled.

EN	Speed/frequency mismatch limit			
DE	Zulässige Differenz			
CL2	{0}	{1o}	{1oc}	{2oc}
2454	✓	✓	✓	✓

n/f/LogicsManager mismatch: Threshold value **1.5 to 8.5 Hz**

The frequency mismatch that is to be monitored is defined here. If the monitored frequency mismatch reaches or exceeds this value for at least the delay time without interruption, the action specified by the alarm class is initiated.

The *LogicsManager* is monitored with respect to his status.

EN	Delay			
DE	Verzögerung			
CL2	{0}	{1o}	{1oc}	{2oc}
2455	✓	✓	✓	✓

n/f/LogicsManager mismatch: Delay **0.02 to 99.99 s**

If the monitored frequency mismatch exceeds the threshold value for the delay time configured here, an alarm will be issued. If the monitored frequency mismatch falls below the threshold (minus the hysteresis) before the delay expires the time will be reset.

EN	Activation frequency			
DE	Überwachung ab			
CL2	{0}	{1o}	{1oc}	{2oc}
2453	✓	✓	✓	✓

n/f/LogicsManager mismatch: Start-up frequency **15 to 85 Hz**

The speed/frequency mismatch monitoring is enabled at this generator frequency.

EN	Alarm class			
DE	Alarmklasse			
CL2	{0}	{1o}	{1oc}	{2oc}
2451	✓	✓	✓	✓

n/f/LogicsManager mismatch: Alarm class **Class A/B/C/D/E/F**

ⓘ See chapter "Alarm" on page 271.

Each limit may be assigned an independent alarm class that specifies what action should be taken when the limit is surpassed.

EN	Self acknowledge			
DE	Selbstquittierend			
CL2	{0}	{1o}	{1oc}	{2oc}
2452	✓	✓	✓	✓

n/f/LogicsManager mismatch: Self acknowledgment **Yes / No**

Yes.....The control automatically clears the alarm if the fault condition is no longer detected.
No.....The control does not automatically reset the alarm when the fault condition is no longer detected. The alarm must be acknowledged and reset by manually pressing the appropriate buttons or by activating the *LogicsManager* output "External acknowledgement" (via a discrete input or via an interface).

Configure Monitoring: Engine, Generator Active Power Mismatch

If enabled, this monitoring function becomes only active if generator power control is enabled (refer to Configure Application: Controller, Load Control on page 225 for more information). If the measured generator power deviates from the power set point by a value exceeding the limit configured in parameter 2925 for a time exceeding the delay configured in parameter 2923, an alarm will be issued.

If this protective function is triggered, the display indicates "**Gen act.pwr mismatch**" and the logical command variable "06.29" will be enabled.

Parameter table

Level	Text	Setting range	Default value
Generator active power mismatch			
	Monitoring	On / Off	On
	Limit	0.0 to 30.0%	5.0 %
	Delay	3 to 65000 s	30 s
	Alarm class	A/B/C/D/E/F	B
	Self acknowledgment	Yes / No	No

Table 3-38: Monitoring - standard values - generator active power mismatch

EN	Monitoring
DE	Überwachung
CL2	{0} {1o} {1oc} {2oc}
2920	✓ ✓ ✓ ✓

Generator active power mismatch: Monitoring On / Off

On.....Monitoring of the generator active power mismatch is carried out according to the following parameters.
Off.....Monitoring is disabled.

EN	Limit
DE	Grenzwert
CL2	{0} {1o} {1oc} {2oc}
2925	✓ ✓ ✓ ✓

Generator active power mismatch: Threshold value 0.0 to 30.0 %

ⓘ This value refers to the generator rated active power (parameter 1752on page 40).

If the difference between the measured generator power and the power set point exceeds this value for at least the delay time (parameter 2923) without interruption, the action specified by the alarm class is initiated.

EN	Delay
DE	Verzögerung
CL2	{0} {1o} {1oc} {2oc}
2923	✓ ✓ ✓ ✓

Generator active power mismatch: Delay 3 to 65000 s

If the monitored active power mismatch exceeds the threshold value configured in parameter 2925 for the delay time configured here, an alarm will be issued. If the monitored active power mismatch falls below the threshold (minus the hysteresis) before the delay expires the time will be reset.

EN	Alarm class
DE	Alarmklasse
CL2	{0} {1o} {1oc} {2oc}
2921	✓ ✓ ✓ ✓

Generator active power mismatch: Alarm class Class A/B/C/D/E/F

ⓘ See chapter "Alarm" on page 271.

Each limit may be assigned an independent alarm class that specifies what action should be taken when the limit is surpassed.

EN	Self acknowledge
DE	Selbstquittierend
CL2	{0} {1o} {1oc} {2oc}
2922	✓ ✓ ✓ ✓

Generator active power mismatch: Self acknowledge Yes / No

Yes.....The control automatically clears the alarm if the fault condition is no longer detected.
No.....The control does not automatically reset the alarm when the fault condition is no longer detected. The alarm must be acknowledged and reset by manually pressing the appropriate buttons or by activating the *LogicsManager* output "External acknowledgement" (via a discrete input or via an interface).

Configure Monitoring: Engine, Mains Active Power Mismatch

If enabled, this monitoring function becomes only active if generator power control is enabled and the active power set point is configured to "Import" or "Export" (refer to Configure Application: Controller, Load Control on page 225 for more information). If the measured import or export power deviates from the power set point by a value exceeding the limit configured in parameter 2935 for a time exceeding the delay configured in parameter 2933, an alarm will be issued.

If this protective function is triggered, the display indicates "Mns act.pwr mismatch" and the logical command variable "07.16" will be enabled.

Parameter table

Level	Text	Setting range	Default value
Mains active power mismatch			
	Monitoring	On / Off	On
	Limit	1.0 to 99.9%	5.0 %
	Delay	3 to 65000 s	30 s
	Alarm class	A/B/C/D/E/F	B
	Self acknowledgment	Yes / No	No

Table 3-39: Monitoring - standard values - mains active power mismatch

EN	Monitoring				
DE	Überwachung				
CL2	{0}	{1o}	{1oc}	{2oc}	
2930	✓	✓	✓	✓	

Mains active power mismatch: Monitoring **On / Off**

On Monitoring of the mains active power mismatch is carried out according to the following parameters.
Off..... Monitoring is disabled.

EN	Limit				
DE	Grenzwert				
CL2	{0}	{1o}	{1oc}	{2oc}	
2935	✓	✓	✓	✓	

Mains active power mismatch: Threshold value **1.0 to 99.9 %**

ⓘ This value refers to the mains rated active power (parameter 1748on page 40).

If the difference between the measured import or export power and the power set point exceeds this value for at least the delay time (parameter 2933) without interruption, the action specified by the alarm class is initiated.

EN	Delay				
DE	Verzögerung				
CL2	{0}	{1o}	{1oc}	{2oc}	
2933	✓	✓	✓	✓	

Mains active power mismatch: Delay **3 to 65000 s**

If the monitored active power mismatch exceeds the threshold value configured in parameter 2935 for the delay time configured here, an alarm will be issued. If the monitored active power mismatch falls below the threshold (minus the hysteresis) before the delay expires the time will be reset.

EN	Alarm class				
DE	Alarmklasse				
CL2	{0}	{1o}	{1oc}	{2oc}	
2931	✓	✓	✓	✓	

Mains active power mismatch: Alarm class **Class A/B/C/D/E/F**

ⓘ See chapter "Alarm" on page 271.

Each limit may be assigned an independent alarm class that specifies what action should be taken when the limit is surpassed.

EN	Self acknowledge				
DE	Selbstquittierend				
CL2	{0}	{1o}	{1oc}	{2oc}	
2932	✓	✓	✓	✓	

Mains active power mismatch: Self acknowledge **Yes / No**

Yes The control automatically clears the alarm if the fault condition is no longer detected.
No..... The control does not automatically reset the alarm when the fault condition is no longer detected. The alarm must be acknowledged and reset by manually pressing the appropriate buttons or by activating the *LogicsManager* output "External acknowledgement" (via a discrete input or via an interface).

Configure Monitoring: Engine, Generator Unloading Mismatch

This monitoring function is always enabled and becomes active when a stop command is issued. Following a stop command, the controller tries to reduce the power before opening the GCB. If the power falls below the unload limit (parameter 3125) before the delay (parameter 3123) expires, a "GCB open" command will be issued. If the controller fails to reduce the power to fall below the unload limit (parameter 3125) before the delay (parameter 3123) expires, a "GCB open" command will be issued together with an alarm.

If this protective function is triggered, the display indicates "**Gen. unloading fault**" and the logical command variable "06.30" will be enabled.

Parameter table

Level	Text	Setting range	Default value
Generator unloading mismatch			
	Unload Limit	0.5 to 99.9%	3.0 %
	Delay	2 to 9999 s	60 s
	Alarm class	A/B/C/D/E/F	B
	Self acknowledgment	Yes / No	No

Table 3-40: Monitoring - standard values - generator unloading mismatch

EN	CL2	{0}	{1o}	{1oc}	{2oc}
DE	3125	✓	✓	✓	✓

Unload Limit

Abschalteleistung

Generator unloading mismatch: Threshold value

0.5 to 99.9 %

ⓘ This value refers to the generator rated active power (parameter 1752 on page 40).

If the monitored generator power falls below this value, a "GCB open" command will be issued.

EN	CL2	{0}	{1o}	{1oc}	{2oc}
DE	3123	✓	✓	✓	✓

Delay

Verzögerung

Generator unloading mismatch: Delay

2 to 9999 s

If the monitored generator power does not fall below the limit configured in parameter 3125 before the time configured here expires, a "GCB open" command will be issued together with an alarm.

EN	CL2	{0}	{1o}	{1oc}	{2oc}
DE	3121	✓	✓	✓	✓

Alarm class

Alarmklasse

Generator unloading mismatch: Alarm class

Class A/B/C/D/E/F

ⓘ See chapter "Alarm" on page 271.

Each limit may be assigned an independent alarm class that specifies what action should be taken when the limit is surpassed.

EN	CL2	{0}	{1o}	{1oc}	{2oc}
DE	3122	✓	✓	✓	✓

Self acknowledge

Selbstquittierend

Generator unloading mismatch: Self acknowledge

Yes / No

Yes.....The control automatically clears the alarm if the fault condition is no longer detected.

No.....The control does not automatically reset the alarm when the fault condition is no longer detected. The alarm must be acknowledged and reset by manually pressing the appropriate buttons or by activating the *LogicsManager* output "External acknowledgement" (via a discrete input or via an interface).

Configure Monitoring: Engine, Start Failure

If it is not possible to start the engine within a configured number of start attempts (refer to Configure Application: Configure Engine, Start/Stop on page 184), an alarm will be initiated.

If this protective function is triggered, the display indicates "**Start fail**" and the logical command variable "05.08" will be enabled.

Parameter table

Level	Text	Setting range	Default value
Engine start failure			
	Monitoring	On / Off	On
	Alarm class	A/B/C/D/E/F	F
	Self acknowledgment	Yes / No	No

Table 3-41: Monitoring - standard values - engine start failure

EN	Monitoring				
DE	Überwachung				
CL2	{0}	{1o}	{1oc}	{2oc}	
3303	✓	✓	✓	✓	

Start failure: Monitoring **On / Off**

On Monitoring of the start sequence is carried out according to the following parameters.
Off Monitoring is disabled.

EN	Alarm class				
DE	Alarmklasse				
CL2	{0}	{1o}	{1oc}	{2oc}	
3304	✓	✓	✓	✓	

Startup failure: Alarm class **Class A/B/C/D/E/F**

| ⓘ See chapter "Alarm" on page 271. |

Each limit may be assigned an independent alarm class that specifies what action should be taken when the limit is surpassed.

EN	Self acknowledge				
DE	Selbstquittierend				
CL2	{0}	{1o}	{1oc}	{2oc}	
3305	✓	✓	✓	✓	

Start failure: Self acknowledgment **Yes / No**

Yes The control automatically clears the alarm if the fault condition is no longer detected.
No The control does not automatically reset the alarm when the fault condition is no longer detected. The alarm must be acknowledged and reset by manually pressing the appropriate buttons or by activating the *LogicsManager* output "External acknowledgement" (via a discrete input or via an interface).

Configure Monitoring: Engine, Shutdown Malfunction

If it is not possible to stop the engine within a configured time, an alarm will be initiated.

If this protective function is triggered, the display indicates "**Eng. stop malfunct.**" and the logical command variable "05.06" will be enabled.

Parameter table

Level	Text	Setting range	Default value
Engine shutdown malfunction			
	Monitoring	On / Off	On
	Maximal stop delay	3 to 999 s	30 s
	Alarm class	A/B/C/D/E/F	F
	Self acknowledgment	Yes / No	No

Table 3-42: Monitoring - standard values - engine shutdown malfunction

EN	Monitoring			
DE	Überwachung			
CL2	{0}	{1o}	{1oc}	{2oc}
2500	✓	✓	✓	✓

Stop failure: Monitoring **On / Off**

On.....Monitoring of the stop sequence is carried out according to the following parameters.

Off.....Monitoring is disabled.

EN	Maximal stop delay			
DE	Verzögerung Abstellstörung			
CL2	{0}	{1o}	{1oc}	{2oc}
2503	✓	✓	✓	✓

Stop failure: Delay **3 to 999 s**

The maximum permissible time between the output of a stop command and the reply that the engine is stopped successfully is defined here. If the engine cannot be stopped within this time (this means speed via the Pickup, frequency via the generator voltage, or the *LogicsManager* is detected) the action specified by the alarm class is initiated.

EN	Alarm class			
DE	Alarmklasse			
CL2	{0}	{1o}	{1oc}	{2oc}
2501	✓	✓	✓	✓

Stop failure: Alarm class **Class A/B/C/D/E/F**

| ⓘ See chapter "Alarm" on page 271. |

Each limit may be assigned an independent alarm class that specifies what action should be taken when the limit is surpassed.

EN	Self acknowledge			
DE	Selbstquittierend			
CL2	{0}	{1o}	{1oc}	{2oc}
2502	✓	✓	✓	✓

Stop failure: Self acknowledgment **Yes / No**

Yes.....The control automatically clears the alarm if the fault condition is no longer detected.

No.....The control does not automatically reset the alarm when the fault condition is no longer detected. The alarm must be acknowledged and reset by manually pressing the appropriate buttons or by activating the *LogicsManager* output "External acknowledgement" (via a discrete input or via an interface).



NOTE

We recommend to assign this monitoring function to a discrete output to be able to shutdown the engine with an external device to provide a shutdown redundancy.

Configure Monitoring: Engine, Unintended Stop

If an engine stop has been detected without a stop command being issued, an alarm will be initiated. If this protective function is triggered, the display indicates "**Unintended stop**" and the logical command variable "05.05" will be enabled.

Parameter table

Level	Text	Setting range	Default value
Engine unintended stop			
	Monitoring	On / Off	On
	Alarm class	A/B/C/D/E/F	F
	Self acknowledgment	Yes / No	No

Table 3-43: Monitoring - standard values - engine unintended stop

EN	Monitoring			
DE	Überwachung			
CL2	{0}	{10}	{10c}	{20c}
2650	✓	✓	✓	✓

Unintended stop: Monitoring **On / Off**

On Monitoring of an unintended stop is carried out according to the following parameters.
Off Monitoring is disabled.

EN	Alarm class			
DE	Alarmklasse			
CL2	{0}	{10}	{10c}	{20c}
2651	✓	✓	✓	✓

Unintended stop: Alarm class **Class A/B/C/D/E/F**

| ⓘ See chapter "Alarm" on page 271. |

Each limit may be assigned an independent alarm class that specifies what action should be taken when the limit is surpassed.

EN	Self acknowledge			
DE	Selbstquittierend			
CL2	{0}	{10}	{10c}	{20c}
2657	✓	✓	✓	✓

Unintended stop: Self acknowledge **Yes / No**

Yes The control automatically clears the alarm if the fault condition is no longer detected.
No The control does not automatically reset the alarm when the fault condition is no longer detected. The alarm must be acknowledged and reset by manually pressing the appropriate buttons or by activating the *LogicsManager* output "External acknowledgement" (via a discrete input or via an interface).

Configure Monitoring: Engine, Operating Range Failure

The operating range failure monitoring issues an alarm if one of the following conditions is fulfilled:

- Check 1: The easYgen tries to close the GCB, but the generator is not within its operating range (parameters 5800, 5801, 5802, or 5803 on page 50)
- Check 2: The easYgen tries to synchronize the GCB, but the busbar or the generator is not within the generator operating range (parameters 5800, 5801, 5802, or 5803 on page 50)
- Check 3: The easYgen tries to close the GCB to the dead busbar, but the busbar voltage is NOT below the dead busbar detection limit (parameter 5820 on page 150)
- Check 4: The easYgen tries to synchronize the GCB, the MCB is closed, but the mains are not within the mains operating range (parameters 5810, 5811, 5812, or 5813 on page 85)
- Check 5: The easYgen tries to close the GCB, the MCB is closed, but the busbar is dead

No alarm will be issued in idle mode. This monitoring function is disabled below firing speed.

If this protective function is triggered, the display indicates "Operat. range failed" and the logical command variable "06.31" will be enabled.

Parameter table

Level	Text	Setting range	Default value
Operating range failure			
	Monitoring	On / Off	On
	Delay	1 to 999 s	30 s
	Alarm class	A/B/C/D/E/F	B
	Self acknowledgment	Yes / No	No

Table 3-44: Monitoring - standard values - engine dead bus operation

EN	Monitoring
DE	Überwachung
CL2 2660	{0} {1o} {1oc} {2oc}
	✓ ✓ ✓ ✓

Operating range failure: Monitoring **On / Off**

On.....Monitoring of the operating range is carried out according to the following parameters.
Off.....Monitoring is disabled.

EN	Delay
DE	Verzögerung
CL2 2663	{0} {1o} {1oc} {2oc}
	✓ ✓ ✓ ✓

Operating range failure: Delay **1 to 999 s**

If one of the above mentioned conditions for an operating range failure is fulfilled, an alarm will be issued. If the respective condition is not fulfilled anymore before the delay time expires, the delay time will be reset.

EN	Alarm class
DE	Alarmklasse
CL2 2661	{0} {1o} {1oc} {2oc}
	✓ ✓ ✓ ✓

Operating range failure: Alarm class **Class A/B/C/D/E/F**

| ⓘ See chapter "Alarm" on page 271. |

Each limit may be assigned an independent alarm class that specifies what action should be taken when the limit is surpassed.

EN	Self acknowledge
DE	Selbstquittierend
CL2 2662	{0} {1o} {1oc} {2oc}
	✓ ✓ ✓ ✓

Operating range failure: Self acknowledge **Yes / No**

Yes.....The control automatically clears the alarm if the fault condition is no longer detected.
No.....The control does not automatically reset the alarm when the fault condition is no longer detected. The alarm must be acknowledged and reset by manually pressing the appropriate buttons or by activating the *LogicsManager* output "External acknowledgement" (via a discrete input or via an interface).



CAUTION

If load-dependent start/stop (refer to Configure Application: Automatic, Load-Dependent Start/Stop on page 195) is enabled, this monitoring function must be configured with a shutdown alarm class (C, D, E, or F) or disable load-dependent start/stop if triggered to ensure that the next engine will be started.

Configure Monitoring: Engine, Charge Alternator (D+)

The charge alternator monitoring issues an alarm if the voltage measured at the auxiliary excitation input D+ (terminal 52) falls below a fix limit. The fix limit depends on the power supply voltage. If a power supply voltage exceeding 16 V is detected, the unit assumes a 24 V system and uses a limit of 20 V. If a power supply voltage below 16 V is detected, the unit assumes a 12 V system and uses a limit of 9 V.

If this protective function is triggered, the display indicates "**Charge alt. low volt**" and the logical command variable "05.11" will be enabled.

Parameter table

Level	Text	Setting range	Default value
Engine charge alternator			
	Monitoring	On / Off	Off
	Delay	2 to 9999 s	10 s
	Alarm class	A/B/C/D/E/F	B
	Self acknowledgment	Yes / No	No
	Delayed by engine speed	Yes / No	Yes

Table 3-45: Monitoring - standard values - engine charge alternator failure

EN	Monitoring				
DE	Überwachung				
CL2	{0}	{1o}	{1oc}	{2oc}	
4050	✓	✓	✓	✓	

Charge alternator failure: Monitoring On / Off

On Monitoring of the charge alternator is carried out according to the following parameters.
Off..... Monitoring is disabled.

EN	Delay				
DE	Verzögerung				
CL2	{0}	{1o}	{1oc}	{2oc}	
4055	✓	✓	✓	✓	

Charge alternator failure: Delay 2 to 9999 s

If the voltage measured at the auxiliary excitation input D+ falls below a fixed limit for the time defined here, an alarm will be issued. If the voltage returns within the limit before the delay time expires, the delay time will be reset.

EN	Alarm class				
DE	Alarmklasse				
CL2	{0}	{1o}	{1oc}	{2oc}	
4051	✓	✓	✓	✓	

Charge alternator failure: Alarm class Class A/B/C/D/E/F

ⓘ See chapter "Alarm" on page 271.

Each limit may be assigned an independent alarm class that specifies what action should be taken when the limit is surpassed.

EN	Self acknowledge				
DE	Selbstquittierend				
CL2	{0}	{1o}	{1oc}	{2oc}	
4052	✓	✓	✓	✓	

Charge alternator failure: Self acknowledge Yes / No

Yes The control automatically clears the alarm if the fault condition is no longer detected.
No..... The control does not automatically reset the alarm when the fault condition is no longer detected. The alarm must be acknowledged and reset by manually pressing the appropriate buttons or by activating the *LogicsManager* output "External acknowledgement" (via a discrete input or via an interface).

EN	Delayed by engine speed				
DE	Verzögert durch Motordrehz.				
CL2	{0}	{1o}	{1oc}	{2oc}	
4053	✓	✓	✓	✓	

Charge alternator failure: Engine delayed monitoring (Level 1/Level 2) Yes / No

Yes Monitoring for fault conditions is not performed until engine delayed monitoring is enabled. The engine monitoring delay time (parameter 3315 on page 186) must expire prior to fault monitoring being enabled for parameters assigned this delay.
No..... Monitoring for this fault condition is continuously enabled regardless of engine speed.

Configure Monitoring: Breaker Monitoring

Configure GCB

Circuit breaker monitoring contains two alarms: A breaker reclose alarm and a breaker open alarm.

Reclose Alarm: If the control initiates a close of the breaker and the breaker fails to close after the configured number of attempts the monitoring CB alarm will be initiated (refer to parameter "GCB maximum closing attempts", parameter 3418 on page 116).

If this protective function is triggered, the display indicates "GCB fail to close" and the logical command variable "08.05" will be enabled.

Breaker Open Alarm: If the control is attempting to open the circuit breaker and it fails to see that the CB is open within the configured time in seconds after issuing the breaker open command then the monitoring CB alarm will be initiated (refer to parameter "GCB open monitoring", parameter 3420 on page 116).

If this protective function is triggered, the display indicates "GCB fail to open" and the logical command variable "08.06" will be enabled.

Parameter table

Level	Text	Setting range	Default value
Breaker monitoring - GCB			
	Monitoring	On / Off	On
	GCB alarm class	A/B/C/D/E/F	C
	GCB maximum closing attempts	1 to 10	5
	GCB open monitoring	0.10 to 5.00 s	2 s

Table 3-46: Monitoring - standard values - breaker monitoring - GCB

GCB monitoring				
GLS Überwachung				
CL2	{0}	{1o}	{1oc}	{2oc}
2600	---	✓	✓	✓

Circuit breaker monitoring GCB: Monitoring On / Off

On Monitoring of the GCB is carried out according to the following parameters.
Off..... Monitoring is disabled.

GCB alarm class				
GLS Alarmklasse				
CL2	{0}	{1o}	{1oc}	{2oc}
2601	---	✓	✓	✓

Circuit breaker monitoring GCB: Alarm class Class A/B/C/D/E/F

[See chapter "Alarm" on page 271.](#)

Each limit may be assigned an independent alarm class that specifies what action should be taken when the limit is surpassed.

GCB maximum closing attempts				
GLS ZU max. Schaltversuche				
CL2	{0}	{1o}	{1oc}	{2oc}
3418	---	---	✓	✓

Breaker monitoring GCB: Max. "GCB close" attempts 1 to 10

The maximum number of breaker closing attempts is configured in this parameter (relay output "Command: close GCB"). When the breaker reaches the configured number of attempts, a "GCB fail to close" alarm is issued. The counter for the closure attempts will be reset as soon as the "Reply GCB" is de-energized for at least 5 seconds to signal a closed GCB.

GCB open monitoring				
GLS AUF Überwachung				
CL2	{0}	{1o}	{1oc}	{2oc}
3420	---	✓	✓	✓

Breaker monitoring GCB: Max. time until reply "GCB open" 0.10 to 5.00 s

If the "Reply GCB" is not detected as energized once this timer expires, a "GCB fail to open" alarm is issued. This timer initiates as soon as the "open breaker" sequence begins. The alarm configured in parameter 2601 is issued.



CAUTION

If load-dependent start/stop (refer to **Configure Application: Automatic, Load-Dependent Start/Stop** on page 195) is enabled, this monitoring function must be configured with a shutdown alarm class (C, D, E, or F) or disable load-dependent start/stop if triggered to ensure that the next engine will be started.

Configure Synchronization GCB

Parameter table

Level	Text	Setting range	Default value
Breaker monitoring - GCB synchronization			
	Monitoring	On / Off	On
	Timeout	3 to 999 s	60 s
	Alarm class	A/B/C/D/E/F	B
	Self acknowledgment	Yes / No	No

Table 3-47: Monitoring - standard values - breaker monitoring - GCB synchronization

EN	Monitoring
DE	Überwachung
CL2	{0} {1o} {1oc} {2oc}
3060	✓ ✓ ✓ ✓

Synchronization GCB: Monitoring On / Off

On Monitoring of the GCB synchronization is carried out according to the following parameters.

Off Monitoring is disabled.

EN	Timeout
DE	Mindestzeit
CL2	{0} {1o} {1oc} {2oc}
3063	✓ ✓ ✓ ✓

Synchronization GCB: Timeout 3 to 999 s

If it was not possible to synchronize the GCB within the time configured here, an alarm will be issued. The message "GCB syn. timeout" is issued and the logical command variable "08.30" will be enabled.

EN	Alarm class
DE	Alarmklasse
CL2	{0} {1o} {1oc} {2oc}
3061	✓ ✓ ✓ ✓

Synchronization GCB: Alarm class Class A/B/C/D/E/F

ⓘ See chapter "Alarm" on page 271.

Each limit may be assigned an independent alarm class that specifies what action should be taken when the limit is surpassed.

EN	Self acknowledge
DE	Selbstquittierend
CL2	{0} {1o} {1oc} {2oc}
3062	✓ ✓ ✓ ✓

Synchronization GCB: Self acknowledge Yes / No

Yes The control automatically clears the alarm if the fault condition is no longer detected.

No The control does not automatically reset the alarm when the fault condition is no longer detected. The alarm must be acknowledged and reset by manually pressing the appropriate buttons or by activating the *LogicsManager* output "External acknowledgement" (via a discrete input or via an interface).



CAUTION

If load-dependent start/stop (refer to Configure Application: Automatic, Load-Dependent Start/Stop on page 195) is enabled, this monitoring function must be configured with a shutdown alarm class (C, D, E, or F) or disable load-dependent start/stop if triggered to ensure that the next engine will be started.

Configure MCB {2oc}



NOTE

If an alarm is detected when attempting to close the MCB, an emergency power operation will be carried out if the "Emergency start with MCB failure" is On.

If an alarm class higher than 'B' class has been selected it will not be possible to start the engine with the setting "Emergency start with MCB failure" (parameter 3408 on page 192) = configured as On in an emergency power condition.

Circuit breaker monitoring contains two alarms: A breaker reclose alarm and a breaker open alarm.

Reclose Alarm: If the control initiates a close of the breaker and the breaker fails to close after the configured number of attempts the monitoring CB alarm will be initiated.

(Refer to parameter "MCB maximum closing attempts", parameter 3419 on page 119).

If this protective function is triggered, the display indicates "MCB fail to close" and the logical command variable "08.07" will be enabled.

Breaker Open Alarm: If the control is attempting to open the circuit breaker and it fails to see that the CB is open within the configured time in seconds after issuing the breaker open command then the monitoring CB alarm will be initiated.

(Refer to parameter "MCB open monitoring", parameter 3421 on page 119).

If this protective function is triggered, the display indicates "MCB fail to open" and the logical command variable "08.08" will be enabled.

The alarm classes have the following influence to the function of the unit.

Fault at 'closing the MCB'

Alarm classes A & B:

- Parameter 2802 on page 192 "Emergency run" = Off
If the MCB cannot be closed, the busbar remains without voltage, until the MCB breaker fault is acknowledged. The control continues attempting to close the MCB.
- Parameter 2802 on page 192 "Emergency run" = On, parameter 3408 on page 192 "Emergency start with MCB failure" = Off
If the MCB cannot be closed, the busbar remains without voltage, until the MCB breaker fault is acknowledged. The control continues attempting to close the MCB.
- Parameter 2802 on page 192 "Emergency run" = On, parameter 3408 on page 192 "Emergency start with MCB failure" = On
If the MCB cannot be closed, an emergency power operation is initiated (the engine is started and the GCB is closed; the busbar is supplied by the generator). If the alarm is acknowledged and if the MCB can be closed, the load is switched to mains supply and the emergency power operation terminates.

Fault at 'opening the MCB'

This fault is processed according to the action described within the alarm classes. As long as the reply is present that the MCB is still closed, the GCB cannot be closed.

Parameter table

Level	Text	Setting range	Default value
Breaker monitoring - MCB			
	Monitoring	On / Off	On
	MCB alarm class	A/B/C/D/E/F	B
	MCB maximum closing attempts	1 to 10	5
	MCB open monitoring	0.10 to 5.00 s	2 s

Table 3-48: Monitoring - standard values - breaker monitoring - MCB

N		MCB monitoring			
DE		NLS Überwachung			
CL2	{0}	{1o}	{1oc}	{2oc}	
2620	---	---	---	✓	

Circuit breaker monitoring MCB: Monitoring **On / Off**

On..... Monitoring of the MCB is carried out according to the following parameters.
Off Monitoring is disabled.

EN		MCB alarm class			
DE		NLS Alarmklasse			
CL2	{0}	{1o}	{1oc}	{2oc}	
2621	---	---	---	✓	

Circuit breaker monitoring MCB: Alarm class **Class A/B**

| ⓘ See chapter "Alarm" on page 271. |

Each limit may be assigned an independent alarm class that specifies what action should be taken when the limit is surpassed.

EN		MCB maximum closing attempts			
DE		NLS ZU max. Schaltversuche			
CL2	{0}	{1o}	{1oc}	{2oc}	
3419	---	---	---	✓	

Breaker monitoring MCB: Max. "MCB close" attempts **1 to 10**

The maximum number of breaker closing attempts is configured in this parameter (relay output "Command: close MCB"). When the breaker reaches the configured number of attempts, an "**MCB fail to close**" alarm is issued. The counter for the closure attempts will be reset as soon as the "Reply MCB" is de-energized for at least 5 seconds to signal a closed MCB.

EN		MCB open monitoring			
DE		NLS AUF Überwachung			
CL2	{0}	{1o}	{1oc}	{2oc}	
3421	---	---	---	✓	

Breaker monitoring MCB: Max. time until reply "MCB open" **0.10 to 5.00 s**

If the "Reply MCB" is not detected as energized once this timer expires, an "**MCB fail to open**" alarm is issued. This timer initiates as soon as the "open breaker" sequence begins. The alarm configured in parameter 2621 is issued.

Configure Synchronization MCB

Parameter table

Level	Text	Setting range	Default value
Breaker monitoring - MCB synchronization			
	Monitoring	On / Off	On
	Timeout	3 to 999 s	60 s
	Alarm class	A/B/C/D/E/F	B
	Self acknowledgment	Yes / No	No

Table 3-49: Monitoring - standard values - breaker monitoring - MCB synchronization

EN	Monitoring
DE	Überwachung
CL2 3070	{0} {1o} {1oc} {2oc}
	✓ ✓ ✓ ✓

Synchronization MCB: Monitoring **On / Off**

On.....Monitoring of the MCB synchronization is carried out according to the following parameters.

Off.....Monitoring is disabled.

EN	Timeout
DE	Mindestzeit
CL2 3073	{0} {1o} {1oc} {2oc}
	✓ ✓ ✓ ✓

Synchronization MCB: Timeout **3 to 999 s**

If it was not possible to synchronize the MCB within the time configured here, an alarm will be issued. The message "MCB syn. timeout" is issued and the logical command variable "08.31" will be enabled.

EN	Alarm class
DE	Alarmklasse
CL2 3071	{0} {1o} {1oc} {2oc}
	✓ ✓ ✓ ✓

Synchronization MCB: Alarm class **Class A/B/C/D/E/F**

| ⓘ See chapter "Alarm" on page 271. |

Each limit may be assigned an independent alarm class that specifies what action should be taken when the limit is surpassed.

EN	Self acknowledge
DE	Selbstquittierend
CL2 3072	{0} {1o} {1oc} {2oc}
	✓ ✓ ✓ ✓

Synchronization MCB: Self acknowledge **Yes / No**

Yes.....The control automatically clears the alarm if the fault condition is no longer detected.

No.....The control does not automatically reset the alarm when the fault condition is no longer detected. The alarm must be acknowledged and reset by manually pressing the appropriate buttons or by activating the *LogicsManager* output "External acknowledgement" (via a discrete input or via an interface).

Configure Monitoring: Breakers, Generator / Busbar / Mains Phase Rotation - {2oc}

Correct phase rotation of the phase voltages ensures that damage will not occur during a breaker closure to either the mains or the generator. The voltage phase rotation alarm checks, if the phase rotation of the measured voltage systems are identical. If the control detects different phase rotations of mains and generator, the alarm will be initiated and a breaker synchronization is inhibited. However, this alarm will not prevent a dead busbar closure, i.e. a dead bus start.

If this protective function is triggered, the display indicates "**Ph.rotation mismatch**" and the logical command variable "08.33" will be enabled.

Parameter table

Level	Text	Setting range	Default value
Phase rotation fault (the hysteresis is 0.7 % of the rated value)			
	Monitoring	On / Off	On
	Alarm class	A/B/C/D/E/F	B
	Self acknowledgment	Yes / No	Yes

Table 3-50: Monitoring - standard values - mains voltage phase rotation



NOTE

This monitoring function is only enabled if Generator voltage measuring (parameter 1851) and Mains voltage measuring (parameter 1853) are configured to "3Ph 4W" or "3Ph 3W" and the measured voltage exceeds 50 % of the rated voltage (parameter 1766) or if Generator voltage measuring (parameter 1851) and Mains voltage measuring (parameter 1853) are configured to "1Ph 2W" (in this case, the phase rotation is not evaluated, but defined by the 1Ph2W phase rotation (parameter 1859)).

EN	Monitoring				
DE	Überwachung				
CL2	{0}	{1o}	{1oc}	{2oc}	
2940	---	---	---	---	✓

Generator /Busbar / Mains phase rotation: Monitoring On / Off

On Phase rotation monitoring is carried out according to the following parameters
Off..... No monitoring is carried out.

EN	Alarm class				
DE	Alarmklasse				
CL2	{0}	{1o}	{1oc}	{2oc}	
2941	---	---	---	---	✓

Generator /Busbar / Mains phase rotation: Alarm class Class A/B/C/D/E/F

ⓘ See chapter "Alarm" on page 271.

Each limit may be assigned an independent alarm class that specifies what action should be taken when the limit is surpassed.

EN	Self acknowledge				
DE	Selbstquittierend				
CL2	{0}	{1o}	{1oc}	{2oc}	
2942	---	---	---	---	✓

Generator /Busbar / Mains phase rotation: Self acknowledgment Yes / No

Yes The control automatically clears the alarm if the fault condition is no longer detected.
No..... The control does not automatically reset the alarm when the fault condition is no longer detected. The alarm must be acknowledged and reset by manually pressing the appropriate buttons or by activating the *LogicsManager* output "External acknowledgement" (via a discrete input or via an interface).

Configure Monitoring: Flexible Limits



CAUTION

Flexible Limits must not be used for protective functions, because the monitoring function is not guaranteed beyond an exceeding of 320 %.



CAUTION

It is not possible to monitor temperature values in Degree Fahrenheit and pressure values in psi. Even if the parameters 3631 or 3630 on page 158 are configured to a value display in °F or psi, flexible limit monitoring always refers to the value in Degree Celsius or bar.

This control offers 16 flexible limits. They may be used for "limit switch" functions of all measured analog values. It is possible to choose between alarm (warning and shutdown) and control operation via the *LogicsManager*.

If an alarm class is triggered, the display indicates "**Flexible limit {x}**", where {x} indicates the flexible limit 1 to 16, or the text configured using ToolKit and the logical command variable "15.{x}" will be enabled. The following parameter description refers to flexible limit 1. The flexible limits 2 through 16 are configured accordingly. The parameter IDs of the flexible limits 2 through 16 are listed in Table 3-54 on page 125.



NOTE

The flexible limits 13 through 16 are disabled during idle mode operation (refer to Configure Application: Configure Engine, Idle Mode on page 190).

Parameter table

Level	Text	Setting range	Default value
Flexible limits monitoring			
	Description	user-defined	Flex. limit {x}
	Monitoring	On / Off	Off
	Monitored data source	[data source]	
	Monitoring at	Overrun / Underrun	Overrun
	Limit	-32000 to 32000	100
	Hysteresis	0 to 32000	1
	Delay	0.02 to 327.00 s	1 s
	Alarm class	A/B/C/D/E/F/Control	B
	Self acknowledgment	Yes / No	No
	Delayed by engine speed	Yes / No	No

Table 3-51: Monitoring - standard values - flexible limits

The flexible limits must be used to monitor analog inputs like oil pressure or coolant temperature for example. We recommend to change the flexible limit description accordingly. Refer to Table 3-52 for configuration examples. Naturally, the analog inputs must be configured accordingly.

Configuration example

Parameter	example for low oil pressure monitoring	example for high coolant temperature monitoring
Description	Oil pressure	Coolant temp.
Monitoring	On	On
Monitored data source	06.01 Analog input 1	06.02 Analog input 2
Monitoring at	Underrun	Overrun
Limit	200 (2.00 bar)	80 (80 °C)
Hysteresis	10	2
Delay	0.50 s	3 s
Alarm class	F	B
Self acknowledgment	No	No
Delayed by engine speed	Yes	No

Table 3-52: Monitoring - flexible limit examples

EN	Description			
DE	Beschreibung			
CL2 T 4208	{0}	{1o}	{1oc}	{2oc}
	✓	✓	✓	✓

FlexLimit {x} [x = 1 to 16]: Description

user-defined

A description for the respective flexible limit may be entered here. The description may have 4 through 16 characters and is displayed instead of the default text if this limit is exceeded.

Note: This parameter may only be configured using ToolKit configuration software

EN	Monitoring			
DE	Überwachung			
CL2 4200	{0}	{1o}	{1oc}	{2oc}
	✓	✓	✓	✓

FlexLimit {x} [x = 1 to 16]: Monitoring

On / Off

On Monitoring of the limit {x} is carried out according to the following parameters.

Off..... Monitoring is disabled.

EN	Monitored data source			
DE	Überwachte Datenquelle			
CL2 4206	{0}	{1o}	{1oc}	{2oc}
	✓	✓	✓	✓

FlexLimit {x} [x = 1 to 16]: Monitored data source

[data source]

Any possible data source may be selected. Use the **↑** and **↓** softkeys to scroll through the list of variables and confirm your selection with the **↵** softkey. Refer to Appendix C: Data Sources on page 307 for a list of all data sources.

- These are for example:
 00.05 Analog input D+
 01.24 Generator total power
 02.14 Mains current L1
 06.01 Analog input 1



Figure 3-13: Monitoring - flexible limits - data source selection

EN	Monitoring at			
DE	Überwachung auf			
CL2 4204	{0}	{1o}	{1oc}	{2oc}
	✓	✓	✓	✓

FlexLimit {x} [x = 1 to 16]: Monitoring for

Overrun / Underrun

Overrun..... The monitored value must exceed the threshold limit for a fault to be recognized.

Underrun..... The monitored value must fall below the threshold limit for a fault to be recognized.

EN	Limit			
DE	Grenzwert			
CL2 4205	{0}	{1o}	{1oc}	{2oc}
	✓	✓	✓	✓

FlexLimit {x} [x = 1 to 16]: Threshold -32000 to 32000

The threshold limit of the value to be monitored is defined by this parameter. If this value is reached or exceeded / fallen below (dependent on parameter 4204) for at least the delay time configured in parameter 4207 the action specified by the alarm class is initiated after the configured delay expires.

The entry format of the threshold depends on the respective analog value. If the monitored analog value has a reference value (refer to Appendix C: Reference Values on page 312), the threshold is expressed as a percentage of this reference value (-320.00 % to 320.00 %). If an analog input is monitored, the threshold refers to the display value format (refer to Appendix C: Display Value Format on page 319 for more information).

Refer to Table 3-53 for examples of how to configure the limit.

Example value	Desired limit	Reference value / display value	Limit entry format
01.24 Total generator real power	160 kW	Generator rated real power (parameter 1752) = 200 kW	8000 (= 80.00 %)
01.09 Generator frequency	51.5 Hz	Rated frequency (parameter 1750) = 50 Hz	10300 (= 103.00 %)
00.01 Engine speed	1256 rpm	Rated speed (parameter 1601) = 1500 rpm	06373 (= 63.73 %)
06.03 Analog input 3 (configured to VDO 5 bar)	4.25 bar	Display in 0.01 bar	00425 (= 4.25 bar)
06.02 Analog input 2 (configured to VDO 150°C)	123 °C	Display in °C	00123 (= 123°C)
06.03. Analog input 3 (configured to Linear, Value at 0% = 0, Value at 100% = 1000)	10 mm	Display in 0.000 m (parameter 1035 on page 167 configured to 0.000m)	00010 (= 0.010 mm)

Table 3-53: Monitoring - flexible limits - analog value examples

EN	Hysteresis			
DE	Hysterese			
CL2 4216	{0}	{1o}	{1oc}	{2oc}
	✓	✓	✓	✓

FlexLimit {x} [x = 1 to 16]: Hysteresis 0 to 32000

During monitoring, the actual value must exceed or fall below one of the limits defined in parameter 4205 to be recognized as out of permissible limits. For a value to register as having returned to the permissible limits, the monitored value must rise above or fall below this value for the hysteresis. The format for entering the hysteresis depends on the monitored analog input and corresponds with the one of the threshold listed in parameter 4205.

EN	Delay			
DE	Verzögerung			
CL2 4207	{0}	{1o}	{1oc}	{2oc}
	✓	✓	✓	✓

FlexLimit {x} [x = 1 to 16]: Delay 00.02 to 327.00 s

If the monitored value exceeds or falls below the threshold value for the delay time configured here, an alarm will be issued. If the monitored value falls below the threshold (plus/minus the hysteresis, dependent on parameter 4204) before the delay expires the time will be reset.

EN	Alarm class			
DE	Alarmklasse			
CL2 4201	{0}	{1o}	{1oc}	{2oc}
	✓	✓	✓	✓

FlexLimit {x} [x = 1 to 16]: Alarm class Class A/B/C/D/E/F/Control

| ⓘ See chapter "Alarm" on page 271. |

Each limit may be assigned an independent alarm class that specifies what action should be taken when the limit is surpassed.

EN	Self acknowledge				FlexLimit {x} [x = 1 to 16]: Self acknowledge	Yes / No
DE	Selbstquittierend					
CL2 4202	{0}	{1o}	{1oc}	{2oc}	<p>Yes The control automatically clears the alarm if the fault condition is no longer detected.</p> <p>No..... The control does not automatically reset the alarm when the fault condition is no longer detected. The alarm must be acknowledged and reset by manually pressing the appropriate buttons, by energizing the appropriate discrete input or via interface.</p>	
	✓	✓	✓	✓		
EN	Delayed by engine speed				FlexLimit {x} [x = 1 to 16]: Engine speed delay	Yes / No
DE	Verzögert durch Motordrehzahl					
CL2 4203	{0}	{1o}	{1oc}	{2oc}	<p>Yes Monitoring for fault conditions is not performed until engine delayed monitoring is enabled. The engine monitoring delay time (parameter 3315 on page 186) must expire prior to fault monitoring being enabled for parameters assigned this delay.</p> <p>No..... Monitoring for this fault condition is continuously enabled regardless of engine speed.</p>	
	✓	✓	✓	✓		

Table 3-54 shows a complete list of the parameter IDs for the flexible limits 1 through 16.

Flexible limit #	Description	Monitoring	Monitored analog input	Monitoring at	Limit	Hysteresis	Delay	Alarm class	Self acknowledge	Delayed by engine speed
1	4208	4200	4206	4204	4205	4216	4207	4201	4202	4203
2	4225	4217	4223	4221	4222	4233	4224	4218	4219	4220
3	4242	4234	4240	4238	4239	4250	4241	4235	4236	4237
4	4259	4251	4257	4255	4256	4267	4258	4252	4253	4254
5	7108	4270	4276	4274	4275	4278	4277	4271	4272	4273
6	7116	4280	4286	4284	4285	4288	4287	4281	4282	4283
7	7124	4290	4296	4294	4295	4298	4297	4291	4292	4293
8	7132	6000	6006	6004	6005	6008	6007	6001	6002	6003
9	7140	6010	6016	6014	6015	6018	6017	6011	6012	6013
10	7148	6020	6026	6024	6025	6028	6027	6021	6022	6022
11	7156	6030	6036	6034	6035	6038	6037	6031	6032	6033
12	7164	6040	6046	6044	6045	6048	6047	6041	6042	6043
13	7172	6050	6056	6054	6055	6058	6057	6051	6052	6053
14	7180	6060	6066	6064	6065	6068	6067	6061	6062	6062
15	7188	6070	6076	6074	6075	6078	6077	6071	6072	6073
16	7196	6080	6086	6084	6085	6088	6087	6081	6082	6083

Table 3-54: Monitoring - flexible limits - parameter IDs

Configure Monitoring: Miscellaneous

Configure Monitoring: Miscellaneous, Alarm Acknowledgement

EN	Time until horn reset			
DE	Zeit Hupenreset			
CL0	{0}	{1o}	{1oc}	{2oc}
1756	✓	✓	✓	✓

Self acknowledgment of the centralized alarm (horn) **0 to 1,000 s**

After each alarm of alarm class B through F occurs, the alarm LED flashes and the horn (command variable 03.05) is enabled. After the delay time 'time until horn reset' has expired, the flashing LED changes into a steady light and the horn (command variable 03.05) is disabled. The alarm LED flashes until the alarm has been acknowledged either via the push button, the *LogicsManager*, or the interface. **Note:** If this parameter is configured to 0, the horn will remain active until it will be acknowledged.

EN	Ext. acknowledge			
DE	Ext. Quittierung			
CL2	{0}	{1o}	{1oc}	{2oc}
12490	✓	✓	✓	✓

Protection: External acknowledgment of alarms *LogicsManager*

It is possible to acknowledge all alarms simultaneously from remote, e.g. with a discrete input. The logical output of the *LogicsManager* has to become TRUE twice. The first time is for acknowledging the horn, the second for all alarm messages. The On-delay time is the minimum time the input signals have to be "1". The Off-delay time is the time how long the input conditions have to be "0" before the next high signal is accepted. Once the conditions of the *LogicsManager* have been fulfilled the alarms will be acknowledged.

ⓘ The first high signal into the discrete input acknowledges the command variable 03.05 (horn). The second high signal acknowledges all inactive alarm messages.

The *LogicsManager* and its default settings are explained on page 273 in Appendix B: "*LogicsManager*".

Configure Monitoring: Miscellaneous, Configure CAN bus overload

The CAN busses are monitored. If the sum of CAN bus messages on all CAN buses together exceeds 32 per 20 ms, an alarm will be initiated.

If this protective function is triggered, the display indicates "**CAN bus overload**" and the logical command variable "08.20" will be enabled.

Parameter table

Level	Text	Setting range	Default value
CANopen interface 1 monitoring			
	Monitoring	On / Off	On
	Delay	0.01 to 650.00 s	5.00 s
	Alarm class	A/B/C/D/E/F	B
	Self acknowledgment	Yes / No	No

Table 3-55: Monitoring - standard values - CAN bus overload

EN	Monitoring				
DE	Überwachung				
CL2	{0}	{1o}	{1oc}	{2oc}	
3145	✓	✓	✓	✓	

CAN bus overload: Monitoring **On / Off**

On CAN bus overload monitoring is carried out according to the following parameters.

Off Monitoring is disabled.

EN	Delay				
DE	Verzögerung				
CL2	{0}	{1o}	{1oc}	{2oc}	
3148	✓	✓	✓	✓	

CAN bus overload: Delay **0.01 to 650.00 s**

If more than 32 CAN bus messages per 20 ms are sent on the CAN bus within this time, the action specified by the alarm class is initiated.

EN	Alarm class				
DE	Alarmlasse				
CL2	{0}	{1o}	{1oc}	{2oc}	
3146	✓	✓	✓	✓	

CAN bus overload: Alarm class **Class A/B/C/D/E/F/Control**

ⓘ See chapter "Alarm" on page 271.

Each limit may be assigned an independent alarm class that specifies what action should be taken when the limit is surpassed.

EN	Self acknowledge				
DE	Selbstquittierend				
CL2	{0}	{1o}	{1oc}	{2oc}	
3147	✓	✓	✓	✓	

CAN bus overload: Self acknowledgment **Yes / No**

Yes The control automatically clears the alarm if the fault condition is no longer detected.

No The control does not automatically reset the alarm when the fault condition is no longer detected. The alarm must be acknowledged and reset by manually pressing the appropriate buttons or by activating the *LogicsManager* output "External acknowledgement" (via a discrete input or via an interface).

Configure Monitoring: Miscellaneous, Configure CAN Interface 1

The CANopen interface 1 is monitored. If the interface does not receive a Receive Process Data Object (RPDO) before the delay expires, an alarm will be initiated.

If this protective function is triggered, the display indicates "CANopen interface 1" and the logical command variable "08.18" will be enabled.

Parameter table

Level	Text	Setting range	Default value
CANopen interface 1 monitoring			
	Monitoring	On / Off	Off
	Delay	0.01 to 650.00 s	0.20 s
	Alarm class	A/B/C/D/E/F	B
	Self acknowledgment	Yes / No	Yes
	Delayed by eng. speed	Yes / No	No

Table 3-56: Monitoring - standard values - CANopen interface 1

<table border="1"> <thead> <tr> <th>EN</th> <th colspan="4">Monitoring</th> </tr> <tr> <th>DE</th> <th colspan="4">Überwachung</th> </tr> </thead> <tbody> <tr> <td>CL2 3150</td> <td>{0} ✓</td> <td>{1o} ✓</td> <td>{1oc} ✓</td> <td>{2oc} ✓</td> </tr> </tbody> </table>	EN	Monitoring				DE	Überwachung				CL2 3150	{0} ✓	{1o} ✓	{1oc} ✓	{2oc} ✓	<p>CANopen Interface 1: Monitoring On / Off</p> <hr/> <p>On.....CANopen interface 1 monitoring is carried out according to the following parameters. OffMonitoring is disabled.</p>
EN	Monitoring															
DE	Überwachung															
CL2 3150	{0} ✓	{1o} ✓	{1oc} ✓	{2oc} ✓												

<table border="1"> <thead> <tr> <th>EN</th> <th colspan="4">Delay</th> </tr> <tr> <th>DE</th> <th colspan="4">Verzögerung</th> </tr> </thead> <tbody> <tr> <td>CL2 3154</td> <td>{0} ✓</td> <td>{1o} ✓</td> <td>{1oc} ✓</td> <td>{2oc} ✓</td> </tr> </tbody> </table>	EN	Delay				DE	Verzögerung				CL2 3154	{0} ✓	{1o} ✓	{1oc} ✓	{2oc} ✓	<p>CANopen Interface 1: Delay 0.01 to 650.00 s</p> <hr/> <p>The maximum receiving break is configured with this parameter. If the interface does not receive an RPDO within this time, the action specified by the alarm class is initiated. The delay timer is re-initialized after every message is received.</p>
EN	Delay															
DE	Verzögerung															
CL2 3154	{0} ✓	{1o} ✓	{1oc} ✓	{2oc} ✓												

<table border="1"> <thead> <tr> <th>EN</th> <th colspan="4">Alarm class</th> </tr> <tr> <th>DE</th> <th colspan="4">Alarmklasse</th> </tr> </thead> <tbody> <tr> <td>CL2 3151</td> <td>{0} ✓</td> <td>{1o} ✓</td> <td>{1oc} ✓</td> <td>{2oc} ✓</td> </tr> </tbody> </table>	EN	Alarm class				DE	Alarmklasse				CL2 3151	{0} ✓	{1o} ✓	{1oc} ✓	{2oc} ✓	<p>CANopen Interface 1: Alarm class Class A/B/C/D/E/F/Control</p> <hr/> <p> ⓘ See chapter "Alarm" on page 271.</p> <p>Each limit may be assigned an independent alarm class that specifies what action should be taken when the limit is surpassed.</p>
EN	Alarm class															
DE	Alarmklasse															
CL2 3151	{0} ✓	{1o} ✓	{1oc} ✓	{2oc} ✓												

<table border="1"> <thead> <tr> <th>EN</th> <th colspan="4">Self acknowledge</th> </tr> <tr> <th>DE</th> <th colspan="4">Selbstquittierend</th> </tr> </thead> <tbody> <tr> <td>CL2 3152</td> <td>{0} ✓</td> <td>{1o} ✓</td> <td>{1oc} ✓</td> <td>{2oc} ✓</td> </tr> </tbody> </table>	EN	Self acknowledge				DE	Selbstquittierend				CL2 3152	{0} ✓	{1o} ✓	{1oc} ✓	{2oc} ✓	<p>CANopen Interface 1: Self acknowledgment Yes / No</p> <hr/> <p>Yes..... The control automatically clears the alarm if the fault condition is no longer detected. No The control does not automatically reset the alarm when the fault condition is no longer detected. The alarm must be acknowledged and reset by manually pressing the appropriate buttons or by activating the <i>LogicsManager</i> output "External acknowledgement" (via a discrete input or via an interface).</p>
EN	Self acknowledge															
DE	Selbstquittierend															
CL2 3152	{0} ✓	{1o} ✓	{1oc} ✓	{2oc} ✓												

<table border="1"> <thead> <tr> <th>EN</th> <th colspan="4">Delayed by eng. speed</th> </tr> <tr> <th>DE</th> <th colspan="4">Verzögert durch Motordrehzahl</th> </tr> </thead> <tbody> <tr> <td>CL2 3153</td> <td>{0} ✓</td> <td>{1o} ✓</td> <td>{1oc} ✓</td> <td>{2oc} ✓</td> </tr> </tbody> </table>	EN	Delayed by eng. speed				DE	Verzögert durch Motordrehzahl				CL2 3153	{0} ✓	{1o} ✓	{1oc} ✓	{2oc} ✓	<p>CANopen Interface 1: Engine delayed Yes / No</p> <hr/> <p>Yes.....Monitoring for fault conditions is not performed until engine delayed monitoring is enabled. The engine monitoring delay time (parameter 3315 on page 186) must expire prior to fault monitoring being enabled for parameters assigned this delay. NoMonitoring for this fault condition is continuously enabled regardless of engine speed.</p>
EN	Delayed by eng. speed															
DE	Verzögert durch Motordrehzahl															
CL2 3153	{0} ✓	{1o} ✓	{1oc} ✓	{2oc} ✓												

Configure Monitoring: Miscellaneous, Configure CAN Interface 2

The CANopen interface 2 is monitored. If the interface does not receive a message from the external expansion board (Node-ID) before the delay expires, an alarm will be initiated.

If this protective function is triggered, the display indicates "CANopen interface 2" and the logical command variable "08.19" will be enabled.

Parameter table

Level	Text	Setting range	Default value
CANopen interface 2 monitoring			
	Monitoring	On / Off	Off
	Delay	0.01 to 650.00 s	0.20 s
	Alarm class	A/B/C/D/E/F	B
	Self acknowledgment	Yes / No	Yes
	Delayed by eng. speed	Yes / No	No

Table 3-57: Monitoring - standard values - CANopen interface 2

EN	Monitoring				
DE	Überwachung				
CL2	{0}	{1o}	{1oc}	{2oc}	
16187	✓	✓	✓	✓	

CANopen Interface 2: Monitoring **On / Off**

On CANopen interface 1 monitoring is carried out according to the following parameters.
Off..... Monitoring is disabled.

EN	Delay				
DE	Verzögerung				
CL2	{0}	{1o}	{1oc}	{2oc}	
16186	✓	✓	✓	✓	

CANopen Interface 2: Delay **0.01 to 650.00 s**

The maximum receiving break is configured with this parameter. If the interface does not receive message from the external expansion board (Node-ID) within this time, the action specified by the alarm class is initiated. The delay timer is re-initialized after every message is received.

EN	Alarm class				
DE	Alarmlasse				
CL2	{0}	{1o}	{1oc}	{2oc}	
16188	✓	✓	✓	✓	

CANopen Interface 2: Alarm class **Class A/B/C/D/E/F/Control**

ⓘ See chapter "Alarm" on page 271.

Each limit may be assigned an independent alarm class that specifies what action should be taken when the limit is surpassed.

EN	Self acknowledge				
DE	Selbstquittierend				
CL2	{0}	{1o}	{1oc}	{2oc}	
16190	✓	✓	✓	✓	

CANopen Interface 2: Self acknowledgment **Yes / No**

Yes The control automatically clears the alarm if the fault condition is no longer detected.
No..... The control does not automatically reset the alarm when the fault condition is no longer detected. The alarm must be acknowledged and reset by manually pressing the appropriate buttons or by activating the *LogicsManager* output "External acknowledgement" (via a discrete input or via an interface).

EN	Delayed by eng. speed				
DE	Verzögert durch Motordrehzahl				
CL2	{0}	{1o}	{1oc}	{2oc}	
16189	✓	✓	✓	✓	

CANopen Interface 2: Engine delayed **Yes / No**

Yes Monitoring for fault conditions is not performed until engine delayed monitoring is enabled. The engine monitoring delay time (parameter 3315 on page 186) must expire prior to fault monitoring being enabled for parameters assigned this delay.
No..... Monitoring for this fault condition is continuously enabled regardless of engine speed.



NOTE

If you are not using the exact amount of external I/O modules you have defined, the monitoring function does not work correct.

Configure Monitoring: Miscellaneous, Configure CAN Interface 2, J1939 Interface

This watchdog triggers if the easYgen is configured to receive J1939 data from an ECU (parameter 15102) connected to the CAN bus to evaluate these data, and no data is received from the ECU.

If this protective function is triggered, the display indicates "CAN fault J1939" and the logical command variable "08.10" will be enabled.

Parameter table

Level	Text	Setting range	Default value
J1939 interface monitoring			
	Monitoring	On / Off	Off
	Delay	2 to 6500 s	10 s
	Alarm class	A/B/C/D/E/F	B
	Self acknowledgment	Yes / No	Yes
	Delayed by eng. speed	Yes / No	No

Table 3-58: Monitoring - standard values - J1939 interface

EN	Monitoring			
DE	Überwachung			
CL2	{0}	{10}	{10c}	{20c}
15110	✓	✓	✓	✓

J1939 Interface: Monitoring **On / Off**

On.....Monitoring of the J1939 interface is carried out according to the following parameters.
OffMonitoring is disabled.

EN	Delay			
DE	Verzögerung			
CL2	{0}	{10}	{10c}	{20c}
15114	✓	✓	✓	✓

J1939 Interface: Delay **2 to 6500 s**

The delay is configured with this parameter. If the interface does not receive a CAN SAE J1939 protocol message before the delay expires, the action specified by the alarm class is initiated. The delay timer is re-initialized after every message is received.

EN	Alarm class			
DE	Alarmklasse			
CL2	{0}	{10}	{10c}	{20c}
15111	✓	✓	✓	✓

J1939 Interface: Alarm class **Class A/B/C/D/E/F**

[ⓘ See chapter "Alarm" on page 271.](#)

Each limit may be assigned an independent alarm class that specifies what action should be taken when the limit is surpassed.

EN	Self acknowledge			
DE	Selbstquittierend			
CL2	{0}	{10}	{10c}	{20c}
15112	✓	✓	✓	✓

J1939 Interface: Self acknowledgment **Yes / No**

Yes.....The control automatically clears the alarm if the fault condition is no longer detected.
NoThe control does not automatically reset the alarm when the fault condition is no longer detected. The alarm must be acknowledged and reset by manually pressing the appropriate buttons or by activating the *LogicsManager* output "External acknowledgement" (via a discrete input or via an interface).

EN	Delayed by engine speed			
DE	Verzögert durch Motordrehzahl			
CL2	{0}	{10}	{10c}	{20c}
15113	✓	✓	✓	✓

J1939 Interface: Engine delayed **Yes / No**

Yes.....Monitoring for fault conditions is not performed until engine delayed monitoring is enabled. The engine monitoring delay time (parameter 3315 on page 186) must expire prior to fault monitoring being enabled for parameters assigned this delay.
NoMonitoring for this fault condition is continuously enabled regardless of engine speed.

Configure Monitoring: J1939 Interface, Configure CAN Interface 2, Red Stop Alarm

This watchdogs monitors, whether a specific alarm bit is received from the CAN J1939 interface. This enables to configure the easYgen in a way that a reaction is caused by this bit (e.g. warning, shutdown).
 If this protective function is triggered, the display indicates "Red stop lamp" and the logical command variable "05.13" will be enabled.

Parameter table

Level	Text	Setting range	Default value
J1939 interface red stop lamp monitoring			
	Monitoring	On / Off	Off
	Delay	0 to 999 s	2 s
	Alarm class	A/B/C/D/E/F	A
	Self acknowledgment	Yes / No	Yes
	Delayed by eng. speed	Yes / No	No

Table 3-59: Monitoring - standard values - J1939 interface red stop lamp

EN	Monitoring			
DE	Überwachung			
CL2	{0}	{1o}	{1oc}	{2oc}
15115	✓	✓	✓	✓

J1939 Interface: Red stop lamp DM1: Monitoring On / Off

On Monitoring of the Red Stop Lamp message from the ECU is carried out according to the following parameters.
Off Monitoring is disabled.

EN	Delay			
DE	Verzögerung			
CL2	{0}	{1o}	{1oc}	{2oc}
15119	✓	✓	✓	✓

J1939 Interface: Red stop lamp DM1: Delay 0 to 999 s

The red stop lamp delay is configured with this parameter. If the ECU sends the Red Stop Lamp On message, the action specified by the alarm class is initiated after the delay configured here expires.

EN	Alarm class			
DE	Alarmklasse			
CL2	{0}	{1o}	{1oc}	{2oc}
15116	✓	✓	✓	✓

J1939 Interface: Red stop lamp DM1: Alarm class Class A/B/C/D/E/F/Control

ⓘ See chapter "Alarm" on page 271.

Each limit may be assigned an independent alarm class that specifies what action should be taken when the limit is surpassed.

EN	Self acknowledge			
DE	Selbstquittierend			
CL2	{0}	{1o}	{1oc}	{2oc}
15117	✓	✓	✓	✓

J1939 Interface: Red stop lamp DM1: Self acknowledgment Yes / No

Yes The control automatically clears the alarm if the fault condition is no longer detected.
No The control does not automatically reset the alarm when the fault condition is no longer detected. The alarm must be acknowledged and reset by manually pressing the appropriate buttons or by activating the *LogicsManager* output "External acknowledgement" (via a discrete input or via an interface).

EN	Delayed by engine speed			
DE	Verzögert durch Motordrehzahl			
CL2	{0}	{1o}	{1oc}	{2oc}
15118	✓	✓	✓	✓

J1939 Interface: Red stop lamp DM1: Engine delayed Yes / No

Yes Monitoring for fault conditions is not performed until engine delayed monitoring is enabled. The engine monitoring delay time (parameter 3315 on page 186) must expire prior to fault monitoring being enabled for parameters assigned this delay.
No Monitoring for this fault condition is continuously enabled regardless of engine speed.

Configure Monitoring: J1939 Interface, Configure CAN Interface 2, Amber Warning Alarm

This watchdogs monitors, whether a specific alarm bit is received from the CAN J1939 interface. This enables to configure the easYgen in a way that a reaction is caused by this bit (e.g. warning, shutdown).

If this protective function is triggered, the display indicates "**Amber warning lamp**" and the logical command variable "05.14" will be enabled.

Parameter table

Level	Text	Setting range	Default value
J1939 interface amber warning lamp monitoring			
	Monitoring	On / Off	Off
	Delay	0 to 999 s	2 s
	Alarm class	A/B/C/D/E/F	A
	Self acknowledgment	Yes / No	Yes
	Delayed by engine speed	Yes / No	No

Table 3-60: Monitoring - standard values - J1939 interface amber warning lamp

EN	Monitoring
DE	Überwachung
CL2	{0} {1o} {1oc} {2oc}
15120	✓ ✓ ✓ ✓

J1939 Interface: Amber warning lamp DM1: Monitoring On / Off

On.....Monitoring of the Amber Warning Lamp message from the ECU is carried out according to the following parameters.
Off.....Monitoring is disabled.

EN	Delay
DE	Verzögerung
CL2	{0} {1o} {1oc} {2oc}
15124	✓ ✓ ✓ ✓

J1939 Interface: Amber warning lamp DM1: Delay 0 to 999 s

The amber warning lamp delay is configured with this parameter. If the ECU sends the Amber Warning Lamp On message, the action specified by the alarm class is initiated after the delay configured here expires.

EN	Alarm class
DE	Alarmklasse
CL2	{0} {1o} {1oc} {2oc}
15121	✓ ✓ ✓ ✓

J1939 Interface: Amber warning lamp DM1: Alarm class Class A/B/C/D/E/F/Control

| ⓘ See chapter "Alarm" on page 271. |

Each limit may be assigned an independent alarm class that specifies what action should be taken when the limit is surpassed.

EN	Self acknowledge
DE	Selbstquittierend
CL2	{0} {1o} {1oc} {2oc}
15122	✓ ✓ ✓ ✓

J1939 Interface: Amber warning lamp DM1: Self acknowledgment Yes / No

Yes.....The control automatically clears the alarm if the fault condition is no longer detected.
No.....The control does not automatically reset the alarm when the fault condition is no longer detected. The alarm must be acknowledged and reset by manually pressing the appropriate buttons or by activating the *LogicsManager* output "External acknowledgement" (via a discrete input or via an interface).

EN	Delayed by engine speed
DE	Verzögert durch Motordrehzahl
CL2	{0} {1o} {1oc} {2oc}
15123	✓ ✓ ✓ ✓

J1939 Interface: Amber warning lamp DM1: Engine delayed Yes / No

Yes.....Monitoring for fault conditions is not performed until engine delayed monitoring is enabled. The engine monitoring delay time (parameter 3315 on page 186) must expire prior to fault monitoring being enabled for parameters assigned this delay.
No.....Monitoring for this fault condition is continuously enabled regardless of engine speed.

Configure Monitoring: Miscellaneous, Battery, Overvoltage (Levels 1 & 2)

There are two battery overvoltage alarm levels available in the control. Both alarms are definite time alarms and are illustrated in the figure below. The figure diagrams a frequency trend and the associated pickup times and length of the alarms. Monitoring of the voltage is done in two steps.

If this protective function is triggered, the display indicates "**Bat. overvoltage 1**" or "**Bat. overvoltage 2**" and the logical command variable "08.01" or "08.02" will be enabled.

Refer to Appendix E: Triggering Characteristics, Figure 3-37 on page 324 for the triggering characteristic of this monitoring function.

Parameter table

The parameter limits represented in this table have identical permissible ranges. Each parameter may be configured with different trip settings to create unique trip characteristics for specific thresholds.

Level	Text	Setting range	Default value
Battery overvoltage (the hysteresis is 0,7 % of the rated value.)			
Level 1	Monitoring	On / Off	On
	Limit	8.0 to 42.0 V	32.0 V
	Delay	0.02 to 99.99 s	5.00 s
	Alarm class	A/B/C/D/E/F/Control	B
	Self acknowledgment	Yes / No	No
	Delayed by engine speed	Yes / No	No
Level 2	Monitoring	On / Off	Off
	Limit	8.0 to 42.0 V	35.0 V
	Delay	0.02 to 99.99 s	1.00 s
	Alarm class	A/B/C/D/E/F/Control	B
	Self acknowledgment	Yes / No	No
	Delayed by engine speed	Yes / No	No

Table 3-61: Monitoring - standard values - battery overvoltage

EN	Monitoring				
DE	Überwachung				
CL2	{0}	{1o}	{1oc}	{2oc}	
3450	✓	✓	✓	✓	
3456					

Battery overvoltage: Monitoring (Level 1/Level 2) On / Off

On..... Overvoltage monitoring of the battery voltage is carried out according to the following parameters. Both values may be configured independent from each other (prerequisite: Level 1 > Level 2).

Off Monitoring is disabled for Level 1 limit and/or Level 2 limit.

EN	Limit				
DE	Grenzwert				
CL2	{0}	{1o}	{1oc}	{2oc}	
3454	✓	✓	✓	✓	
3460					

Battery overvoltage: Threshold value (Level 1/Level 2) 8.0 to 42.0 V

The threshold values that are to be monitored are defined here. If the monitored battery voltage reaches or exceeds this value for at least the delay time without interruption, the action specified by the alarm class is initiated.

EN	Delay				
DE	Verzögerung				
CL2	{0}	{1o}	{1oc}	{2oc}	
3455	✓	✓	✓	✓	
3461					

Battery overvoltage: Delay time (Level 1/Level 2) 0.02 to 99.99 s

If the monitored battery voltage exceeds the threshold value for the delay time configured here, an alarm will be issued. If the monitored battery voltage falls below the threshold (minus the hysteresis) before the delay expires the time will be reset.

EN	Alarm class				
DE	Alarmklasse				
CL2	{0}	{1o}	{1oc}	{2oc}	
3451	✓	✓	✓	✓	
3457					

Battery overvoltage: Alarm class (Level 1/Level 2) Class A/B/C/D/E/F/Control

ⓘ See chapter "Alarm" on page 271.

Each limit may be assigned an independent alarm class that specifies what action should be taken when the limit is surpassed.

DE	EN	Self acknowledge			
DE	EN	Selbstquittierend			
CL2		{0}	{1o}	{1oc}	{2oc}
3452		✓	✓	✓	✓
3458					

Battery overvoltage: Self acknowledgment (Level 1/Level 2) Yes / No

Yes.....The control automatically clears the alarm if the fault condition is no longer detected.

No.....The control does not automatically reset the alarm when the fault condition is no longer detected. The alarm must be acknowledged and reset by manually pressing the appropriate buttons or by activating the *LogicsManager* output "External acknowledgement" (via a discrete input or via an interface).

DE	EN	Delayed by engine speed			
DE	EN	Verzögert durch Motordrehzahl			
CL2		{0}	{1o}	{1oc}	{2oc}
3453		✓	✓	✓	✓
3459					

Battery overvoltage: Engine delayed monitoring (Level 1/Level 2) Yes / No

Yes.....Monitoring for fault conditions is not performed until engine delayed monitoring is enabled. The engine monitoring delay time (parameter 3315 on page 186) must expire prior to fault monitoring being enabled for parameters assigned this delay.

No.....Monitoring for this fault condition is continuously enabled regardless of engine speed.

Configure Monitoring: Miscellaneous, Battery, Undervoltage (Levels 1 & 2)

There are two battery undervoltage alarm levels available in the control. Both alarms are definite time alarms and are illustrated in the figure below. The figure diagrams a frequency trend and the associated pickup times and length of the alarms. Monitoring of the voltage is done in two steps.

If this protective function is triggered, the display indicates "**Bat. undervoltage 1**" or "**Bat. undervoltage 2**" and the logical command variable "08.03" or "08.04" will be enabled.

Refer to Appendix E: Triggering Characteristics, Figure 3-38 on page 325 for the triggering characteristic of this monitoring function.

Parameter table

The parameter limits represented in this table have identical permissible ranges. Each parameter may be configured with different trip settings to create unique trip characteristics for specific thresholds.

Level	Text	Setting range	Default value
Battery undervoltage (the hysteresis is 0.7 % of the rated value).			
Level 1	Monitoring	On / Off	On
	Limit	8.0 to 42.0 V	24.0 V
	Delay	0.02 to 99.99 s	60.00 s
	Alarm class	A/B/C/D/E/F/Control	B
	Self acknowledgment	Yes / No	No
	Delayed by engine speed	Yes / No	No
Level 2	Monitoring	On / Off	On
	Limit	8.0 to 42.0 V	20.0 V
	Delay	0.02 to 99.99 s	10.00 s
	Alarm class	A/B/C/D/E/F/Control	B
	Self acknowledgment	Yes / No	No
	Delayed by engine speed	Yes / No	No

Table 3-62: Monitoring - standard values - battery undervoltage

EN	Monitoring				
DE	Überwachung				
CL2	{0}	{1o}	{1oc}	{2oc}	
3500	✓	✓	✓	✓	
3506					

Battery undervoltage: Monitoring (Level 1/Level 2) On / Off

On Undervoltage monitoring of the battery voltage is carried out according to the following parameters. Both values may be configured independent from each other (prerequisite: Level 1 > Level 2).

Off Monitoring is disabled for Level 1 limit and/or Level 2 limit.

EN	Limit				
DE	Grenzwert				
CL2	{0}	{1o}	{1oc}	{2oc}	
3504	✓	✓	✓	✓	
3510					

Battery undervoltage: Threshold value (Level 1/Level 2) 8.0 to 42.0 V

The threshold values that are to be monitored are defined here. If the monitored battery voltage reaches or falls below this value for at least the delay time without interruption, the action specified by the alarm class is initiated.

Note

The default monitoring limit for battery undervoltage is 24 Vdc after 60 seconds. This is because in normal operation the terminal voltage is approximately 26 Vdc (alternator charged battery).

EN	Delay				
DE	Verzögerung				
CL2	{0}	{1o}	{1oc}	{2oc}	
3505	✓	✓	✓	✓	
3511					

Battery undervoltage: Delay time (Level 1/Level 2) 0.02 to 99.99 s

If the battery voltage falls below the threshold value for the delay time configured here, an alarm will be issued. If the battery voltage exceeds the threshold (plus the hysteresis) again before the delay expires the time will be reset.

EN	Alarm class				
DE	Alarmklasse				
CL2	{0}	{1o}	{1oc}	{2oc}	
3501	✓	✓	✓	✓	
3507					

Battery undervoltage: Alarm class (Level 1/Level 2) Class A/B/C/D/E/F/Control

ⓘ See chapter "Alarm" on page 271.

Each limit may be assigned an independent alarm class that specifies what action should be taken when the limit is surpassed.

DE	EN	Self acknowledge			
		Selbstquittierend			
CL2		{0}	{1o}	{1oc}	{2oc}
3502		✓	✓	✓	✓
3508					

Battery undervoltage: Self acknowledgment (Level 1/Level 2) Yes / No

- Yes**.....The control automatically clears the alarm if the fault condition is no longer detected.
- No**The control does not automatically reset the alarm when the fault condition is no longer detected. The alarm must be acknowledged and reset by manually pressing the appropriate buttons or by activating the *LogicsManager* output "External acknowledgement" (via a discrete input or via an interface).

DE	EN	Delayed by engine speed			
		Verzögert durch Motordrehzahl			
CL2		{0}	{1o}	{1oc}	{2oc}
3503		✓	✓	✓	✓
3509					

Battery undervoltage: Engine delayed monitoring (Level 1/Level 2) Yes / No

- Yes**.....Monitoring for fault conditions is not performed until engine delayed monitoring is enabled. The engine monitoring delay time (parameter 3315 on page 186) must expire prior to fault monitoring being enabled for parameters assigned this delay.
- No**Monitoring for this fault condition is continuously enabled regardless of engine speed.

Configure Monitoring: Miscellaneous, Multi-Unit Parameter Alignment

The multi-unit parameter alignment functionality requires that the relevant parameters are all configured identically at all participating units.

If at least one of these parameters is configured different in at least one of the units, the display indicates "Parameter alignment" on all units and the logical command variable "08.16" will be enabled.

This alarm is always self-acknowledging, i.e. the control automatically clears the alarm if it is no longer valid.

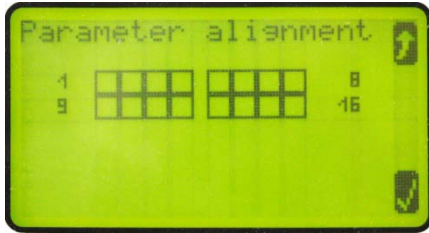



Figure 3-14: Monitoring - miscellaneous – parameter alignment

-  Participating unit is different configured
-  Participating unit is identical configured

The setting of the following parameters will be monitored:

- Start stop mode (parameter 5752 on page 198)
- Fit size of engine (parameter 5754 on page 199)
- Fit service hours (parameter 5755 on page 200)
- Changes of engines (parameter 5756 on page 201)
- IOP Reserve power (parameter 5760 on page 203)
- IOP Hysteresis (parameter 5761 on page 203)
- IOP Max. generator load (parameter 5762 on page 203)
- IOP Min. generator load (parameter 5763 on page 204)
- IOP Dynamic (parameter 5757 on page 205)
- IOP Add on delay (parameter 5764 on page 206)
- IOP Add on delay at rated load (parameter 5765 on page 206)
- IOP Add off delay (parameter 5766 on page 206)
- MOP Minimum load (parameter 5767 on page 207)
- MOP Reserve power (parameter 5768 on page 207)
- MOP Hysteresis (parameter 5769 on page 207)
- MOP Max. generator load (parameter 5770 on page 208)
- MOP Min. generator load (parameter 5771 on page 208)
- MOP Dynamic (parameter 5758 on page 209)
- MOP Add on delay (parameter 5772 on page 210)
- MOP Add on delay at rated load (parameter 5773 on page 210)
- MOP Add off delay (parameter 5774 on page 210)
- Transfer rate LS fast message (parameter 9921 on page 262)

Parameter table

Level	Text	Setting range	Default value
Multi-unit parameter alignment monitoring			
	Monitoring	On / Off	On
	Alarm class	A/B/C/D/E/F	B

Table 3-63: Monitoring - standard values - multi-unit parameter alignment monitoring

EN	Monitoring				Multi-unit parameter alignment: Enable	On / Off
DE	Überwachung					
CL2	{0}	{1o}	{1oc}	{2oc}	On	Multi-unit parameter alignment monitoring is carried out.
4070	✓	✓	✓	✓	Off	Monitoring is disabled.

	Alarm class			
DE	{0}	{1o}	{1oc}	{2oc}
EN				
CL2	✓	✓	✓	✓
4071				

Multi-unit configuration check: Alarm class Class A/B/C/D/E/F

See chapter "Alarm" on page 271.

This function may be assigned an independent alarm class that specifies what action should be taken when this function triggers an alarm.

Configure Monitoring: Miscellaneous, Multi-Unit Missing Members

The multi-unit missing members monitoring function checks whether all participating units are available (sending data on the load share line).

If the number of available units is less than the number of members configured in parameter 4063 for at least the delay time (refer to below note), the display indicates "Missing members" and the logical command variable "08.17" will be enabled.



NOTE

After energizing the easYgen, a delay is started, which allows a possible "Missing members" alarm to become active. This delay depends on the Node-ID of the easYgen (parameter 8950 on page 248) and the transfer rate of a load share fast message (parameter 9921 on page 262) and may last for approx. 140 seconds for a high Node-ID (e.g. 127). This delay serves for detecting the Master of a CAN bus connection. Approximately two minutes after energizing the easYgen, the alarm delay will be set to a fix time, which depends on the setting of parameter 9921 on page 262 (Transfer rate LS fast message) and is in the range between 3 to 12 seconds.

Parameter table

Level	Text	Setting range	Default value
Multi-unit missing members monitoring			
	Monitoring	On / Off	Off
	Number of gens communicating	0 to 32	2
	Alarm class	A/B/C/D/E/F	B
	Self acknowledge	Yes / No	No

Table 3-64: Monitoring - standard values - multi-unit missing members monitoring

<table border="0"> <tr> <td>EN</td> <td colspan="4" style="text-align: center;">Monitoring</td> </tr> <tr> <td>DE</td> <td colspan="4" style="text-align: center;">Überwachung</td> </tr> <tr> <td>CL2</td> <td>{0}</td> <td>{10}</td> <td>{10c}</td> <td>{20c}</td> </tr> <tr> <td>4060</td> <td>✓</td> <td>✓</td> <td>✓</td> <td>✓</td> </tr> </table>	EN	Monitoring				DE	Überwachung				CL2	{0}	{10}	{10c}	{20c}	4060	✓	✓	✓	✓	<p>Multi-unit missing members monitoring: Enable On / Off</p> <hr/> <p>On..... Multi-unit missing members monitoring is carried out. Off..... Monitoring is disabled.</p>
EN	Monitoring																				
DE	Überwachung																				
CL2	{0}	{10}	{10c}	{20c}																	
4060	✓	✓	✓	✓																	
<table border="0"> <tr> <td>EN</td> <td colspan="4" style="text-align: center;">Number of gens communicating</td> </tr> <tr> <td>DE</td> <td colspan="4" style="text-align: center;">Anzahl Teilnehmer</td> </tr> <tr> <td>CL2</td> <td>{0}</td> <td>{10}</td> <td>{10c}</td> <td>{20c}</td> </tr> <tr> <td>4063</td> <td>✓</td> <td>✓</td> <td>✓</td> <td>✓</td> </tr> </table>	EN	Number of gens communicating				DE	Anzahl Teilnehmer				CL2	{0}	{10}	{10c}	{20c}	4063	✓	✓	✓	✓	<p>Multi-unit missing members monitoring: Number of participants 0 to 64</p> <hr/> <p>The number of units participating in load sharing is configured here.</p>
EN	Number of gens communicating																				
DE	Anzahl Teilnehmer																				
CL2	{0}	{10}	{10c}	{20c}																	
4063	✓	✓	✓	✓																	
<table border="0"> <tr> <td>EN</td> <td colspan="4" style="text-align: center;">Alarm class</td> </tr> <tr> <td>DE</td> <td colspan="4" style="text-align: center;">Alarmklasse</td> </tr> <tr> <td>CL2</td> <td>{0}</td> <td>{10}</td> <td>{10c}</td> <td>{20c}</td> </tr> <tr> <td>4061</td> <td>✓</td> <td>✓</td> <td>✓</td> <td>✓</td> </tr> </table>	EN	Alarm class				DE	Alarmklasse				CL2	{0}	{10}	{10c}	{20c}	4061	✓	✓	✓	✓	<p>Multi-unit missing members monitoring: Alarm class Class A/B/C/D/E/F</p> <hr/> <p>See chapter "Alarm" on page 271.</p> <p>This function may be assigned an independent alarm class that specifies what action should be taken when this function triggers an alarm.</p>
EN	Alarm class																				
DE	Alarmklasse																				
CL2	{0}	{10}	{10c}	{20c}																	
4061	✓	✓	✓	✓																	
<table border="0"> <tr> <td>EN</td> <td colspan="4" style="text-align: center;">Self acknowledge</td> </tr> <tr> <td>DE</td> <td colspan="4" style="text-align: center;">Selbstquittierend</td> </tr> <tr> <td>CL2</td> <td>{0}</td> <td>{10}</td> <td>{10c}</td> <td>{20c}</td> </tr> <tr> <td>4062</td> <td>✓</td> <td>✓</td> <td>✓</td> <td>✓</td> </tr> </table>	EN	Self acknowledge				DE	Selbstquittierend				CL2	{0}	{10}	{10c}	{20c}	4062	✓	✓	✓	✓	<p>Multi-unit missing members monitoring: Self acknowledgment Yes / No</p> <hr/> <p>Yes The control automatically clears the alarm if the fault condition is no longer detected. No The control does not automatically reset the alarm when the fault condition is no longer detected. The alarm must be acknowledged and reset by manually pressing the appropriate buttons or by activating the <i>LogicsManager</i> output "External acknowledgement" (via a discrete input or via an interface).</p>
EN	Self acknowledge																				
DE	Selbstquittierend																				
CL2	{0}	{10}	{10c}	{20c}																	
4062	✓	✓	✓	✓																	

Configure Application



Configure Application: Configure Breakers

i **NOTE**
 The assignment of the defined relays to defined functions occurs by selection of the application mode (i.e. function "Command: Close GCB" on relay [R 6], this relay can no longer be operated via the *LogicsManager*). The same way some relays are designated to specific functions, others may be assigned to different functions. These are listed as "programmed" relays. If a relay is "programmable" the function may be assigned to other relays via the *LogicsManager* by configuration. Refer to Table 3-78 on page 172 for more information.

i **NOTE**
 If the easYgen is intended to be operated in parallel with the mains, the mains voltage measuring inputs must be connected. If an external mains decoupling is performed, jumpers between busbar and mains voltage measuring inputs may be installed.

i **NOTE**
 Changing the application mode will not change other configured values in the parameters. The application mode parameter is the only one.

Parameter table

Level	Text	Setting range	Default value
Configure breakers			
	Application mode	GCB/MCB / GCB / GCB open / None	GCB/MCB
	Breaker transition mode	Parallel / Interchange / Closed Transit. / Open Transition / External	Parallel
	Breaker transition mode 1	Parallel / Interchange / Closed Transit. / Open Transition / External	Parallel
	Transition mode 1	<i>LogicsManager</i>	(0 & 1) & 1
	Transfer time GCB↔MCB	1.00 to 99.99 s	1.00 s
	Dead bus detection max. volt.	0 to 30 %	10 %

Table 3-65: Application - standard values - configure breakers

	Application mode			
	{0}	{1o}	{1oc}	{2oc}
EN				
DE				
CL2	✓	✓	✓	✓
3401				

Application modes "None" / "GCB open" / "GCB" / "GCB/MCB"

The unit may be configured for four different application modes. The discrete inputs and relay outputs are pre-defined dependent upon the selected application mode. Only the screens and functions that pertain to the application mode selected are displayed. The single line diagram in the main screen will change. Refer to the Operation manual 37428 for additional information.

- None**..... Application mode {0} "Engine Control" [start/stop]
The control unit will function as an engine start/stop control with generator and engine protection. All necessary inputs and outputs are assigned and pre-defined.
- GCB open**.... Application mode {1o} "Protection" [open GCB]
The control unit will function as an engine start/stop control with generator and engine protection. The control unit can only open the GCB. All necessary inputs and outputs are assigned and pre-defined.
- GCB** Application mode {1oc} "1-CB control" [open/close GCB]
The control unit will function as a 1 CB unit. The control unit performs full control like synchronizing, opening and closing the GCB with generator and engine protection. All necessary inputs and outputs are assigned and pre-defined.
- GCB/MCB**... Application mode {2oc} "2 CB control" [open/close GCB/MCB]
The control unit will function as a 2 CB unit. The control unit performs full control like synchronizing, opening and closing the GCB and the MCB with generator and engine protection. The GCB/MCB perform also full load transfer via open/closed transition, interchange and parallel mode. All necessary inputs and outputs are assigned and pre-defined.

Operation Of The Circuit Breakers

The configuration of pulse switching takes place in the following screen and has the described effect on the signal sequence (the MCB cannot be controlled by the continuous pulse for security reasons, because otherwise, the MCB would be opened in case of a failure/exchange of the easYgen). The parameter "Enable MCB" allows/prevents the closing of the MCB. A closed MCB will not be opened. If the parameter "Auto unlock" is configured to YES, an open pulse will be issued prior to each close pulse.

Dead bus closing GCB {1oc} or {2oc}

The unit closes the GCB, if the following conditions are met. The display indicates "GCB dead bus cls".

Automatic operation

- The operating mode AUTOMATIC has been selected
- No class C alarm or higher is present
- The engine is running
- The engine delayed monitoring (parameter 3315 on page 186) as well as the generator stable time (parameter 3415 on page 153) have been expired or the *LogicsManager* function "Undelay close GCB" (parameter 12210 on page 153) is enabled
- The generator voltage and frequency are within the configured operating range (refer to Configure Monitoring: Generator, Operating Voltage / Frequency on page 50)
- The MCB has been opened for at least the time configured in "Transfer time GCB↔MCB" (parameter 3400 on page 150) ({2oc} with open transition mode only)
- The busbar voltage is below the dead bus detection limit (parameter 5820 on page 150)

Manual operation

- The operating mode MANUAL has been selected.
- No class C alarm or higher is present
- The engine is running
- The engine delayed monitoring (parameter 3315 on page 186) as well as the generator stable time (parameter 3415 on page 153) have been expired
- The generator voltage and frequency are within the configured operating range (refer to Configure Monitoring: Generator, Operating Voltage / Frequency on page 50)
- The button "Close GCB" has been pressed
- The MCB has been open for at least the time configured in "Transfer time GCB↔MCB" (parameter 3400 on page 150) ({2oc} with open transition mode only)
- The busbar voltage is below the dead bus detection limit (parameter 5820 on page 150)

Synchronization GCB/MCB {1oc} or {2oc}

The synchronization is active, if the following conditions are met simultaneously. The display indicates "Synchronization GCB" or "Synchronization MCB".

Automatic operation

- The operating mode AUTOMATIC has been selected
- The mains voltage is available and within the configured operating range (refer to Configure Monitoring: Mains, Operating Voltage / Frequency on page 85)
- The generator and busbar voltage are available and within the configured operating range (refer to Configure Monitoring: Generator, Operating Voltage / Frequency on page 50)
- The differential frequency/voltage is within the configured operating range

Synchronizing the MCB

- The GCB is closed (or at least one GCB is closed in a multiple genset application)
- The busbar voltage is within the configured operating range
- The "Enable MCB" (parameter 12923 on page 157) signal is present, for example discrete input 6 is energized if configured as DI 6

Synchronizing the GCB

- The MCB is closed
- The busbar voltage is within the configured operating range
- Engine delayed monitoring (parameter 3315 on page 186) and generator stable time (parameter 3415 on page 153) have expired or "Undelay close GCB" (parameter 12210 on page 153) is enabled

Manual operation

- Operating mode MANUAL has been selected
- The mains voltage is available and within the configured operating range (refer to Configure Monitoring: Mains, Operating Voltage / Frequency on page 85)
- The generator and busbar voltage is available and within the configured operating range (refer to Configure Monitoring: Generator, Operating Voltage / Frequency on page 50)
- The differential frequency/voltage is within the configured operating range

Synchronizing the MCB

- The GCB is closed (or at least one GCB is closed in a multiple genset application)
- The busbar voltage is within the configured operating range
- The "Enable MCB" (parameter 12923 on page 157) signal is present, for example discrete input 6 is energized if configured as DI 6
- The button "Close MCB" has been pressed

Synchronizing the GCB

- The MCB is closed
- The busbar voltage is within the configured operating range
- Engine delayed monitoring (parameter 3315 on page 186) and generator stable time (parameter 3415 on page 153) have expired or "Undelay close GCB" (parameter 12210 on page 153) is enabled
- The button "Close GCB" has been pressed

Dead bus start MCB {2oc}

The unit closes the MCB, if the following conditions are met simultaneously. The display indicates "MCB dead bus cls".

Automatic operation

- The operating mode AUTOMATIC has been selected
- The parameter "Dead busbar closure MCB" (parameter 3431 on page 156) is configured On
- The mains voltage is available and within the configured operating range (refer to Configure Monitoring: Mains, Operating Voltage / Frequency on page 85)
- The GCB is open or has been opened for at least the "Transfer time GCB \leftrightarrow MCB" (parameter 3400 on page 150) (open transition mode only)
- The "Enable MCB" (parameter 12923 on page 157) signal is present, for example discrete input 6 is energized if configured as DI 6
- The busbar voltage is below the dead bus detection limit (parameter 5820 on page 150)

Manual operation

- Operating mode MANUAL has been selected
- The parameter "Dead busbar closure MCB" (parameter 3431 on page 156) is configured On
- The mains voltage is available and within the configured operating range (refer to Configure Monitoring: Mains, Operating Voltage / Frequency on page 85)
- The GCB is open or has been opened for at least the "Transfer time GCB \leftrightarrow MCB" (parameter 3400 on page 150) (open transition mode only)
- The "Enable MCB" (parameter 12923 on page 157) signal is present, for example discrete input 6 is energized if configured so
- The button "Close MCB" has been pressed
- The busbar voltage is below the dead bus detection limit (parameter 5820 on page 150)

Open GCB {1o} or {1oc} or {2oc}

The GCB will be opened when the "Command GCB open" is issued. The behavior of the GCB open relay depends on the setting of parameter 3403 on page 151. If this parameter is configured as "N.O.", the relay energizes to open the GCB, if it is configured as "N.C.", the relay de-energizes to open the GCB. The GCB will be opened under the following conditions.

- In STOP operating mode after unloading the generator
- In case of a class C alarm or higher
- By pressing the "GCB" or "MCB" softkey (depending on the CB logic which has been set) in MANUAL operating mode
- By pressing the button "stop engine" in MANUAL operating mode
- In the event of an automatic stopping in the AUTOMATIC operating mode (the start request has been terminated or a stop request has been initiated)
- By pressing the "MCB" softkey (depending on the CB logic which has been set) in MANUAL operating mode

Above conditions are only valid if the GCB is closed, whereas the following conditions are valid regardless of the GCB is open or closed.

- Prior to the MCB closing onto the dead busbar (depending on the CB logic which has been set)
- In case of an alarm of class D or F

Open MCB {2oc}

The MCB will be opened when the relay "Command: MCB open" is energized. The MCB will be opened under the following conditions if the MCB is closed.

- If an emergency power operation is initiated (mains failure) once the generator voltage is within the permissible limits
- Prior to the closure of the GCB (depending on the CB logic which has been set)
- Upon pressing the "MCB" or "GCB" softkey (dependent upon the configured CB logic) in MANUAL operating mode

Transition Mode

EN	Breaker transition mode				Breaker: Transition mode	Parallel / Interchange / Closed T. / Open T. / External
DE	Schaltermodus					
CL2 3411	{0}	{1o}	{1oc}	{2oc}	The control unit automatically controls the two breakers (MCB and GCB). Up to five (5) breaker logic modes may be selected. These are:	
	---	---	---	✓		

{1oc}	{2oc}
---	EXTERNAL
PARALLEL	PARALLEL
---	OPEN TRANSITION
---	CLOSED TRANSITION
---	INTERCHANGE

A detailed explanation for each mode may be found in the following text.

Alternative Transition Modes

The unit provides two alternative transition modes, which may be activated temporarily via the *LogicsManager* and override the transition mode configured in parameter 3411.

EN	Breaker transition mode 1				Breaker: Transition mode 1	Parallel / Interchange / Closed T. / Open T. / External
DE	Schaltermodus Alternative 1					
CL2 3412	{0}	{1o}	{1oc}	{2oc}	The control unit automatically controls the two breakers (MCB and GCB). Up to five (5) breaker logic modes may be selected. These are:	
	---	---	---	✓		

{1oc}	{2oc}
---	EXTERNAL
PARALLEL	PARALLEL
---	OPEN TRANSITION
---	CLOSED TRANSITION
---	INTERCHANGE

A detailed explanation for each mode may be found in the following text.

EN	Transition mode 1				Breaker: Transition mode 1	<i>LogicsManager</i>
DE	LS-Modus Alternat. 1					
CL2 12931	{0}	{1o}	{1oc}	{2oc}	Once the conditions of the <i>LogicsManager</i> have been fulfilled, the transition mode configured in parameter 3412 will be used instead of the standard transition mode configured in parameter 3411. The <i>LogicsManager</i> and its default settings are explained on page 273 in Appendix B: " <i>LogicsManager</i> ".	
	---	---	---	✓		

Breaker Logic "PARALLEL"

Parallel operation is enabled by configuring parameter 3411 to "PARALLEL".

**NOTE**

Parallel breaker logic must be selected for the following operation modes:

- Isolated operation
- Mains parallel operation

In the event of an engine start request the following occurs:

- The GCB is synchronized and closed
- The generator assumes load and the adjusted real power or reactive power set points are controlled

Following the stop request the following occurs:

- The generator sheds load until real power has reached the "Unload limit" (parameter 3125)
- The generator power factor is controlled to "1.00" (unity)
- The GCB is opened
- The engine is shut down following the configured cool down period

**NOTE**

When a stop command is issued to the engine, soft loading (power reduction) is carried out before opening the GCB, except an alarm of class D or F is present.

Breaker Logic "INTERCHANGE" {2oc}

Mains interchange (import/export) real power control is enabled by configuring parameter 3411 to "INTERCHANGE".

**NOTE**

For this breaker logic to function correctly, the mains power measurement must be connected properly. The following applies for the power display:

- **Positive mains power = export power**
- **Negative mains power = import power**

In the event of a start request, a change is made from mains to generator supply. The following occurs:

- The GCB is synchronized and closed
- The generator assumes load until the imported mains interchange real power has reached 3 % of the "Generator rated active power" (parameter 1752)
- The MCB is opened

When a stop request has been issued, a change is made from generator to mains supply. The following occurs:

- The MCB is synchronized and closed
- The generator sheds load until real power has reached the "Unload limit" (parameter 3125)
- The generator power factor is controlled to "1.00" (unity)
- The GCB is opened

Breaker Logic "CLOSED TRANSIT." {2oc}

Closed transition (make-before-break/overlap synchronization) is enabled by configuring parameter 3411 to "CLOSED TRANSITION".

**NOTE**

The circuit breakers are opened irrespective of the power.

In the event of an engine start request, a change is made from mains to generator supply. The following occurs:

- The GCB is synchronized and closed
- The MCB is opened and the generator assumes all loads

After the engine stop request has been issued, a change is made from generator to mains supply. The following occurs:

- The MCB is synchronized and closed
- The GCB is opened and the mains assume all loads

**NOTE**

The maximum time between the reply from the CB and the CB open command is 500 ms.

Breaker Logic "OPEN TRANSIT." {2oc}

Open transition (break-before-make/change over logic) is enabled via configuration of parameter 3411 to "OPEN TRANSITION".

In the event of an engine start request, a change is made from mains to generator supply. The following occurs:

- The MCB is opened
- The GCB is closed after the time configured in "Transfer time GCB<->MCB" (parameter 3400 on page 150) has expired

After the engine stop request has been issued, a change is made from generator to mains supply. The following occurs:

- The GCB is opened
- The MCB is closed after the time configured in "Transfer time GCB<->MCB" parameter 3400 on page 150 has expired

Breaker Logic "EXTERNAL"

External breaker logic is enabled via configuration of parameter 3411 to "EXTERNAL".

All breaker control (especially the CB closing instructions) must be carried out via master controller (e.g. a PLC). The easYgen controller always issues additionally the breaker open command under fault conditions and in the breaker unloading states (Unloading GCB) if the stop request is active.

Overview {2oc}

STOP	MANUAL	AUTOMATIC
EXTERNAL: Breaker logic "External" In a mains parallel operation, decoupling from the mains is carried out via the MCB or the GCB in the event of a mains failure. The breakers will not automatically close in emergency power operation. Emergency power operation in accordance with European Community Specification DIN VDE 0108 is not possible in this power circuit breaker logic.		
The GCB is opened.	The MCB and the GCB may be manually opened. The circuit breakers are opened for decoupling from the mains.	The GCB is opened if the genset is stopped or if decoupling from the mains, but will not close if the engine is started. The MCB is opened only if decoupling from the mains, and is never closed.

PARALLEL: Breaker logic "Mains parallel operation" The MCB and GCB are synchronized to permit continuous mains parallel operation in this breaker logic mode.		
The GCB is opened; the MCB is operated depending on the setting of "Enable MCB" (parameter 12923).	Mains parallel operation can be initiated by pressing the "GCB On" or "MCB On" push-button.	The GCB is synchronized via an add-on request and a mains parallel operation is performed. When a shed-off request is issued, the generator sheds load and opens the GCB and the engine is shut down following the configured cool down period. <u>Emergency power:</u> The emergency power operation is terminated following the expiration of the mains settling time. The MCB is synchronized and closed, putting the system back into a mains parallel operation.

OPEN TRANSIT.: Breaker logic "Open transition / change-over / brake-before-make" The MCB and GCB are never synchronized in this breaker logic mode.		
The GCB is opened; the MCB is operated depending on the setting of "Enable MCB" (parameter 12923).	A change can be made to either generator or mains operation by pressing either the "GCB On" or "MCB On" push-button. The "STOP" push-button opens the GCB and simultaneously stops the engine.	A change is made to generator operation through an add-on request. Once the add-on request is terminated, the system changes back to mains operation. The MCB is closed when the busbar is dead, even if there has not been an add-on request. Emergency power operations are terminated following the expiration of the mains settling timer. The GCB opens and the MCB closes, transferring all loads to the mains.

CLOSED TRANSIT.: Breaker logic "Closed transition / make-before-brake / overlap synchronization" The MCB and the GCB are synchronized, in order to avoid a dead busbar in this breaker logic mode. Immediately after the synchronization of one breaker, the other is opened. Continuous mains parallel operation is not possible.		
The GCB is opened; the MCB is operated depending on the setting of "Enable MCB" (parameter 12923).	Synchronization of either the generator or the mains can be initiated by pressing the "GCB On" or "MCB On" push-button.	The GCB is synchronized via an add-on request. After the GCB closes the MCB is opened. Following the shed-off request being issued, the MCB is synchronized and closed. After the MCB has closed the GCB is opened. <u>Emergency power:</u> The emergency power operation is terminated following the expiration of the mains settling time and the MCB synchronizing to the generator. The MCB closes and the GCB opens immediately afterwards.

Overview {2oc} (continued)

STOP	MANUAL	AUTOMATIC
<p>INTERCHANGE: Breaker logic "Soft loading / interchange synchronization" The MCB and the GCB are synchronized, in order to avoid a dead busbar in this breaker logic mode. The operation of a breaker under load is avoided by utilizing the ability to soft load. Continuous mains parallel operation is not possible with this breaker logic. Following the shed-off request, the MCB synchronizes and closes, the generator soft unloads to the mains and the GCB opens. After the GCB is open the engine is stopped following the expiration of the configured cool down period.</p>		
<p>The GCB is opened; the MCB is operated depending on the setting of "Enable MCB" (parameter 12923).</p>	<p>Synchronization of either the generator or the mains can be initiated by pressing the "GCB On" or "MCB On" push-button.</p>	<p>Via an engine request, the GCB is synchronized and the generator power is increased. The MCB is then opened. Following the disabling of the engine request, the MCB is reverse synchronized and the GCB is then opened.</p> <p><u>Emergency power:</u> The emergency power operation is terminated following the expiration of the mains settling time. The MCB closes, the load is transferred, and the GCB opens.</p>

Overview {1oc}

STOP	MANUAL	AUTOMATIC
<p>PARALLEL: Breaker logic "Mains parallel" This operation mode may be used both in the case of an isolated system, an isolated parallel system, and a system that is operated in mains parallel.</p>		
<p>The GCB is opened.</p>	<p>Mains parallel operation can be performed via the "GCB On" push-button.</p>	<p>The GCB is synchronized via an add-on request and mains parallel operation is performed. When a shed-off request is issued, the generator sheds load, the GCB is opened, and the engine is shut down following the configured cool down period.</p>

EN	Transfer time GCB↔MCB			
DE	Pausenzeit GLS↔NLS			
CL2	{0}	{1o}	{1oc}	{2oc}
3400	---	---	---	✓

Breaker: Transfer time GCB ↔ MCB **0.10 to 99.99 s**

Switching from generator supply to mains supply or from mains supply to generator supply occurs automatically if the operating conditions have been met. The time between the reply "power circuit breaker is open" and a close pulse is set by this parameter. This time applies for both directions. During this time the consumers are de-energized.

Note: This is only valid, if parameter 3411 on page 145 is configured to OPEN TRANSITION

Configure Application: Configure Breakers, Dead Bus Detection Limit

EN	Dead bus detection max. volt.			
DE	Max. Spannung für SamS schwarz			
CL2	{0}	{1o}	{1oc}	{2oc}
5820	✓	✓	✓	✓

Operating values, maximum voltage for dead bus detection **0 to 30 %**

If the busbar voltage falls below this percentage of the busbar 1 rated voltage (parameter 1781 on page 40), a dead bus condition is detected and the logical command variable 02.21 (Busbar 1 is dead) becomes TRUE.

Configure Application: Configure Breakers, GCB



NOTE

Normally Open Contacts (No): If a voltage is applied to the discrete input terminals, the discrete input is enabled (i.e. in the operating state). The controller only recognizes a fault condition or control operation via the discrete input when the discrete input terminals are energized. If fault monitoring is performed via Normally Open contacts, the state of the system should be monitored by the state of the discrete input.

Normally Closed Contacts (NC): If a voltage is applied to the discrete input terminals, the discrete input is not enabled (i.e. in the idle state). The controller only recognizes a fault condition or control operation via the discrete input when the discrete input terminals are de-energized.

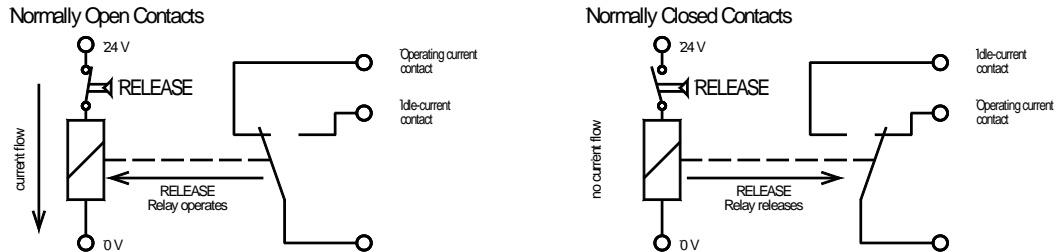

Figure 3-15: Normally Open / Normally Closed contacts

Parameter table

Level	Text	Setting range	Default value
Configure GCB			
	GCB open relay	N.O. / N.C. / Not used	N.O.
	GCB close command	Constant / Impulse	Constant
	GCB time pulse	0.10 to 0.50 s	0.50 s
	Synchroniztion GCB	Slip frequency / Phase matching	Slip frequency
	Voltage differential GCB	0.50 to 20.00 %	5.00 %
	Pos. freq. differential GCB	0.02 to 0.49 Hz	+0.18 Hz
	Neg. freq. differential GCB	-0.49 to 0.00 Hz	-0.10 Hz
	Max. positive phase angle GCB	0.0 to 60.0 °	7.0 °
	Max. negative phase angle GCB	-60.0 to 0.0 °	-7.0 °
	Phase matching GCB dwell time	0.0 to 60.0 s	3.0 s
	Dead bus closure	On / Off	On
	Generator stable time	0 to 99 s	2 s
	Closing time GCB	40 to 300 ms	80 ms
	Undelay close GCB	LogicsManager	(04.09 & 1) & 1

Table 3-66: Application - standard values - configure GCB

EN	GCB open relay				
DE	GLS Öffnen-Kontakt				
CL2	{0}	{1o}	{1oc}	{2oc}	
3403	---	✓	✓	✓	

Breaker: "Command: GCB open" relay N.O. / N.C. / Not used

N.O. (normally open) ... The relay "command: GCB open" will be energized to open the GCB and will be de-energized again after the discrete input "Reply GCB" is energized to signal the control that the GCB is open.

N.C. (normally closed) . The relay "command: GCB open" will be de-energized to open the GCB and will be energized again after the discrete input "Reply GCB" is energized to signal the control that the GCB is open.

Not used..... A GCB open relay is not used and relay R7 (Command: open GCB) is freely programmable. In this case, parameter 3414 must be configured to "Constant" to open the breaker.

EN	GCB close command			
DE	GLS Schließen-Befehl			
CL2	{0}	{1o}	{1oc}	{2oc}
3414	---	---	✓	✓

Breaker: "Command: GCB close" Constant / Impulse

ImpulseThe relay "Command: GCB close" issues an add-on pulse. If the relay is configured in this manner a holding coil and sealing contacts must be installed externally to the control unit. The DI "Reply GCB" is used to identify closed contacts.

Constant.....The relay "Command: close GCB" may be wired directly into the holding circuit for the power circuit breaker. If this method is utilized it is recommended that isolation relays are used. After the connect pulse has been issued and the reply of the power circuit breaker has been received, the relay "Command: close GCB" remains energized. If a class C alarm or higher occurs or a GCB open command is issued, this relay de-energizes.

In both cases the relay "Command: GCB open" energizes to open the GCB if parameter 3403 is not configured as "Not used".

EN	GCB time pulse			
DE	GLS Impulsdauer			
CL2	{0}	{1o}	{1oc}	{2oc}
3416	---	✓	✓	✓

Breaker: Pulse duration to close the GCB 0.10 to 0.50 s

The time of the pulse output may be adjusted to the breaker being utilized.

EN	Synchronization GCB			
DE	Synchronisierung GLS			
CL2	{0}	{1o}	{1oc}	{2oc}
5729	---	---	---	✓

Breaker: Synchronization frequency GCB Slip frequency / Phase matching

Slip frequency The frequency controller adjusts the frequency in a way, that the frequency of the source (generator) is marginal greater than the target (busbar). When the synchronizing conditions are reached, a close command will be issued. The slipping frequency depends on the setting of "Slip frequency offset" (parameter 5502 on page 223).

Phase matching .. The frequency controller adjusts the phase angle of the source (generator) to that of the target (busbar), in view of turning the phase difference to zero.

EN	Voltage differential GCB			
DE	Max. Spg. Differenz GLS			
CL2	{0}	{1o}	{1oc}	{2oc}
5700	---	---	✓	✓

Breaker: Voltage differential GCB 0.50 to 20.00 %

ⓘ This value refers to the generator rated voltage (parameter 1766 on page 40).

The maximum permissible voltage differential for closing the generator circuit breaker is configured here.

If the difference between generator and busbar voltage does not exceed the value configured here and the generator voltage is within the operating voltage window (parameters 5800/5801 on page 50), the "Command: GCB close" may be issued.

EN	Pos. freq. differential GCB			
DE	Max. positiver Schlupf GLS			
CL2	{0}	{1o}	{1oc}	{2oc}
5701	---	---	✓	✓

Breaker: Positive frequency differential GCB 0.02 to 0.49 Hz

The prerequisite for a close command being issued for the GCB is that the differential frequency is below the configured differential frequency. This value specifies the upper frequency (positive value corresponds to positive slip → generator frequency is higher than the busbar frequency).

EN	Neg. freq. differential GCB			
DE	Max. negativer Schlupf GLS			
CL2	{0}	{1o}	{1oc}	{2oc}
5702	---	---	✓	✓

Breaker: Negative frequency differential GCB -0.49 to 0.00 Hz

The prerequisite for a close command being issued for the GCB is that the differential frequency is above the configured differential frequency. This value specifies the lower frequency limit (negative value corresponds to negative slip → generator frequency is less than the busbar frequency).

EN	Max positive phase angle GCB			
DE	Max. pos. Winkeldifferenz GLS			
CL2	{0}	{1o}	{1oc}	{2oc}
5703	---	---	✓	✓

Breaker: Max. permissible positive phase angle GCB 0.0 to 60.0 °

① This parameter is only displayed, if parameter 5729 is configured to "Phase matching".

The prerequisite for a close command being issued for the GCB is that the leading phase angle between generator and busbar is below the configured maximum permissible angle.

EN	Max negative phase angle GCB			
DE	Max. neg. Winkeldifferenz GLS			
CL2	{0}	{1o}	{1oc}	{2oc}
5704	---	---	✓	✓

Breaker: Max. permissible negative phase angle GCB -60.0 to 0.0 °

① This parameter is only displayed, if parameter 5729 is configured to "Phase matching".

The prerequisite for a close command being issued for the GCB is that the lagging phase angle between generator and busbar is above the configured minimum permissible angle.

EN	Phase matching GCB dwell time			
DE	Verweildauer GLS			
CL2	{0}	{1o}	{1oc}	{2oc}
5707	---	---	✓	✓

Breaker: Phase matching dwell time of GCB 0.0 to 60.0 s

① This parameter is only displayed, if parameter 5729 is configured to "Phase matching".

This is the minimum time that the generator voltage, frequency, and phase angle must be within the configured limits before the breaker will be closed.

EN	Dead bus closure GCB			
DE	Schwarz schließen GLS			
CL2	{0}	{1o}	{1oc}	{2oc}
3432	---	---	✓	✓

Breaker: Dead busbar closure GCB On / Off

On.....A dead busbar closure is allowed if the required conditions are met.
Off.....A GCB close command to a dead busbar is prevented. A synchronization is still possible.

EN	Generator stable time			
DE	Wartezeit vor GLS schließen			
CL2	{0}	{1o}	{1oc}	{2oc}
3415	---	✓	✓	✓

Breaker: "Command: GCB close": Breaker delay 0 to 99 s

The time configured here begins to count down once the engine monitoring delay timer has expired. This permits for an additional delay time before the breaker is closed in order to ensure that none of the engine delayed watchdogs trips. It is possible to bypass this delay time through the *LogicsManager* (parameter 12210 on page 153) in the event an emergency operation condition (mains failure) occurs.

Unnecessary CB switching operations and voltage interruptions should be avoided by utilizing this parameter.

EN	Closing time GCB			
DE	Schaltzeit GLS			
CL2	{0}	{1o}	{1oc}	{2oc}
5705	---	---	✓	✓

Inherent delay of GCB for synchronization 40 to 300 ms

The inherent closing time of the GCB corresponds to the lead-time of the close command. The close command will be issued independent of the differential frequency at the entered time before the synchronous point.

EN	Undelay close GCB			
DE	GLS unverzögert			
CL2	{0}	{1o}	{1oc}	{2oc}
12210	---	---	✓	✓

Breaker: Undelay closing of the GCB *LogicsManager*

Once the conditions of the *LogicsManager* have been fulfilled the GCB will be closed immediately (without waiting for engine speed delay and generator stable timer to expire). When using the standard setting, the GCB will be closed without delay in emergency power operation. The *LogicsManager* and its default settings are explained on page 273 in Appendix B: "*LogicsManager*".

		GCB auto unlock				Breaker: Breaker unblocking GCB	Yes / No
EN							
DE		GLS auto entriegeln					
CL2	{0}	{1o}	{1oc}	{2oc}	This is used for special circuit breakers to put the breaker into a defined initial state or to enable closing at all. YESBefore every close-pulse, an open-pulse is issued for 1 second. A CB close pulse is enabled only after the open pulse is issued. NOThe CB close pulse is enabled without being preceded by a CB open pulse.		
3405	---	---	✓	✓			

		GCB open time pulse				Breaker: GCB open time pulse	0.10 to 9.90 s
EN							
DE		GLS öffnen Impulsdauer					
CL2	{0}	{1o}	{1oc}	{2oc}	This time defines the length of the GCB open time pulse, if the automatic switch unblocking GCB is activated.		
5708	---	---	✓	✓			

Configure Application: Configure Breakers, MCB

Parameter table

Level	Text	Setting range	Default value
Configure MCB			
	MCB control (easYgen-2200)	Off / 1 Relay	1 Relay
	MCB control (easYgen-2500)	Off / 1 Relay / 2 Relays	2 Relays
	MCB time pulse	0.10 to 0.50 s	0.50 s
	Synchroniztion MCB	Slip frequency / Phase matching	Slip frequency
	Voltage differential MCB	0.50 to 20.00 %	5.00 %
	Pos. freq. differential MCB	0.02 to 0.49 Hz	+0.18 Hz
	Neg. freq. differential MCB	-0.49 to 0.00 Hz	-0.10 Hz
	Max. positive phase angle MCB	0.0 to 60.0 °	7.0 °
	Max. negative phase angle MCB	-60.0 to 0.0 °	-7.0 °
	Phase matching MCB dwell time	0.0 to 60.0 s	3.0 s
	Dead bus closure	On / Off	On
	Enable MCB	<i>LogicsManager</i>	(09.06 & !08.07) & !07.05
	Closing time MCB	40 to 300 ms	80 ms

Table 3-67: Application - standard values - configure MCB

EN	MCB control			
DE	NLS Ansteuerung			
CL2	{0}	{1o}	{1oc}	{2oc}
5732	---	---	---	✓

Breaker: MCB control (easYgen-2200) Off / 1 Relay

OffA MCB is not operated. Relay R5 (38/39/40) can be freely used.
1 RelayA MCB is operated and if necessary monitored. Relay R5 (38/39/40) is used and fixed to this function.

EN	MCB control			
DE	NLS Ansteuerung			
CL2	{0}	{1o}	{1oc}	{2oc}
5733	---	---	---	✓

Breaker: MCB control (easYgen-2500) Off / 1 Relay / 2 Relays

OffA MCB is not operated. Relay R5 (38/39/40) can be freely used.
1 RelayA MCB is operated and if necessary monitored. Relay R5 (38/39/40) is used and fixed to this function.
2 Relays.....A MCB is operated and if necessary monitored. Relay R5 (38/39/40) is used for the open function, relay R8 (82/83) to close it. The opening and closing is carried out with the pulse method.



NOTE

Even if the MCB operation (Parameter 5732/5733) is switched off and the breaker application mode is configured to GCB/MCB, the reply of the MCB is observed anyway.

EN	MCB time pulse			
DE	NLS Impulsdauer			
CL2	{0}	{1o}	{1oc}	{2oc}
3417	---	---	---	✓

Breaker: Pulse duration to close the MCB 0.10 to 0.50 s

The time of the pulse output may be adjusted to the breaker being utilized.

EN	Synchronization MCB			
DE	Synchronisierung NLS			
CL2	{0}	{1o}	{1oc}	{2oc}
5730	---	---	---	✓

Breaker: Synchronization frequency MCB Slip frequency / Phase matching

Slip frequency The frequency controller adjusts the frequency in a way, that the frequency of the source (busbar) is marginal greater than the target (mains). When the synchronizing conditions are reached, a close command will be issued. The slipping frequency is positive to avoid reverse power.

Phase matching The frequency controller adjusts the phase angle of the source (busbar) to that of the target (mains), in view of turning the phase difference to zero.

EN	Voltage differential MCB			
DE	Max. Spg. Differenz NLS			
CL2	{0}	{1o}	{1oc}	{2oc}
5710	---	---	---	✓

Breaker: Voltage differential MCB **0.50 to 20.00 %**

① This value refers to the mains rated voltage (parameter 1768 on page 40).

The maximum permissible voltage differential for closing the mains circuit breaker is configured here.
 If the difference between mains and busbar voltage does not exceed the value configured here and the mains voltage is within the operating voltage window (parameters 5810/5811 on page 86), the "Command: MCB close" may be issued.

EN	Pos. freq. differential MCB			
DE	Max. positiver Schlupf NLS			
CL2	{0}	{1o}	{1oc}	{2oc}
5711	---	---	---	✓

Breaker: Positive frequency differential MCB **0.02 to 0.49 Hz**

The prerequisite for a connect command being issued for the MCB is that the differential frequency is below the configured differential frequency. This value specifies the upper frequency (positive value corresponds to positive slip → busbar frequency is higher than the mains frequency).

EN	Neg. freq. differential MCB			
DE	Max. negativer Schlupf NLS			
CL2	{0}	{1o}	{1oc}	{2oc}
5712	---	---	---	✓

Breaker: Negative frequency differential MCB **-0.49 to 0.00 Hz**

The prerequisite for a connect command being issued for the MCB is that the differential frequency is above the configured differential frequency. This value specifies the lower frequency limit (negative value corresponds to negative slip → busbar frequency is less than the mains frequency).

EN	Max positive phase angle MCB			
DE	Max. positive Winkeldiff. NLS			
CL2	{0}	{1o}	{1oc}	{2oc}
5713	---	---	---	✓

Breaker: Max. permissible positive phase angle MCB **0.0 to 60.0 °**

① This parameter is only displayed, if parameter 5730 is configured to "Phase matching".

The prerequisite for a connect command being issued for the MCB is that the leading phase angle between busbar and mains is below the configured maximum permissible angle.

EN	Max negative phase angle MCB			
DE	Max. negative Winkeldiff. NLS			
CL2	{0}	{1o}	{1oc}	{2oc}
5714	---	---	---	✓

Breaker: Max. permissible negative phase angle MCB **-60.0 to 0.0 °**

① This parameter is only displayed, if parameter 5730 is configured to "Phase matching".

The prerequisite for a connect command being issued for the MCB is that the lagging phase angle between busbar and mains is above the configured minimum permissible angle.

EN	Phase matching MCB dwell time			
DE	Verweildauer NLS			
CL2	{0}	{1o}	{1oc}	{2oc}
5717	---	---	---	✓

Breaker: Phase matching dwell time of MCB **0.0 to 60.0 s**

① This parameter is only displayed, if parameter 5730 is configured to "Phase matching".

This is the minimum time that the generator/busbar voltage, frequency, and phase angle must be within the configured limits before the breaker will be closed.

EN	Dead bus closure MCB			
DE	Schwarz schließen MCB			
CL2	{0}	{1o}	{1oc}	{2oc}
3431	---	---	---	✓

Breaker: Dead busbar closure MCB **On / Off**

On..... A dead busbar closure is allowed if the required conditions are met.

Off An MCB close command to a dead busbar is prevented. A synchronization is still possible.

EN	Enable MCB			
DE	Freigabe NLS			
CL2	{0}	{1o}	{1oc}	{2oc}
12923	---	---	---	✓

Breaker: Enable MCB *LogicsManager*

Once the conditions of the *LogicsManager* have been fulfilled the MCB will be enabled. The *LogicsManager* and its default settings are explained on page 273 in Appendix B: "*LogicsManager*".
DI 6 is pre-assigned by default to this function, but may be configured freely.

EN	Closing time MCB			
DE	Schaltereigenzeit NLS			
CL2	{0}	{1o}	{1oc}	{2oc}
5715	---	---	---	✓

Breaker: Synchronization: Inherent delay of MCB for synchronization 40 to 300 ms

The inherent closing time of the MCB corresponds to the lead-time of the close command. The close command will be issued independent of the differential frequency at the entered time before the synchronous point.

EN	MCB auto unlock			
DE	NLS auto entriegeln			
CL2	{0}	{1o}	{1oc}	{2oc}
3407	---	---	✓	✓

Breaker: Switch unblocking MCB Yes / No

This is used for special circuit breakers to put the breaker into a defined initial state or to enable closing at all.
YES..... Before every close-pulse, an open-pulse is issued for 1 second. A CB close pulse is enabled only after the open pulse is issued.
NO The CB close pulse is enabled without being preceded by a CB open pulse.

EN	MCB open time pulse			
DE	NLS öffnen Impulsdauer			
CL2	{0}	{1o}	{1oc}	{2oc}
5718	---	---	✓	✓

Breaker: MCB open time pulse 0.10 to 9.90 s

This time defines the length of the MCB open time pulse, if the automatic switch unblocking MCB is activated.

Configure Application: Configure Breakers, Synchronization

Parameter table

Level	Text	Setting range	Default value
Configure synchronization			
	Synchronization mode	Off / Permissice / Check / Run	RUN

Table 3-68: Application - standard values - configure synchronization

EN	Synchronization mode			
DE	Synchronisiermodus			
CL2	{0}	{1o}	{1oc}	{2oc}
5728	---	---	---	✓

Breaker: Synchronization mode Off / Permissive / Check / Run / Controlled by LM

Off The synchronization is disabled; the frequency and voltage adaptation for synchronization is not active.

Permissive... The unit acts as a synch check device. The unit will not issue speed or voltage bias commands to achieve a synchronization, but if synchronization conditions are matched (frequency, phase, voltage and phase angle), the control will issue a breaker close command. There are two different functionalities of this option depending on the setting of parameter 3414 on page 152 (GCB close command):
GCB close command set to Impulse
The GCB close command is pulsed as long as the synchronization conditions are matched.
GCB close command set to Constant
The GCB close command remains enabled as long as the synchronization conditions are matched.

Check Used for checking a synchronizer prior to commissioning. The control actively synchronizes generator(s) by issuing speed and voltage bias commands, but **does not issue a breaker closure command**.

Run..... Normal operating mode. The control actively synchronizes and issues breaker closure commands.

Configure Application: Configure Inputs and Outputs

Configure Analog Inputs (*FlexIn*)

Parameter table

Level	Text	Setting range	Default value
Configure analog inputs			
	Display temperature in	°C / °F	°C
	Display pressure in	bar / psi	bar

Table 3-69: Application - standard values - configure analog inputs

EN	Display temperature in	Temperature display in	°C / °F
DE	Temperaturanzeige in		
CL1	{0} {10} {10c} {20c}	°C..... The temperature is displayed in °C (Celsius).	
3631	✓ ✓ ✓ ✓	°F..... The temperature is displayed in °F (Fahrenheit).	
EN	Display pressure in	Pressure display in	bar / psi
DE	Druckanzeige in		
CL1	{0} {10} {10c} {20c}	bar..... The pressure is displayed in Bar.	
3630	✓ ✓ ✓ ✓	psi..... The pressure is displayed in psi.	



NOTE

Refer to the Application Manual 37429 for a detailed configuration example of an analog input.

Analog Inputs: Characteristics "Table A" And "Table B" (9 Point Scaling)

The characteristic curves of "Table A" and "Table B" (freely configurable over 9 defined percentage points) are independently configurable for all analog inputs. Each percentage point may be scaled to related values measured from the analog input (0 to 500 Ohm or 0 to 20 mA), so that the actual display reflects the measured values (i.e. 200 to 600 kW). The so developed characteristic curve can be used for visualization and monitoring via the configuration to "Table A" (for Table A) as well as "Table B" (for Table B).

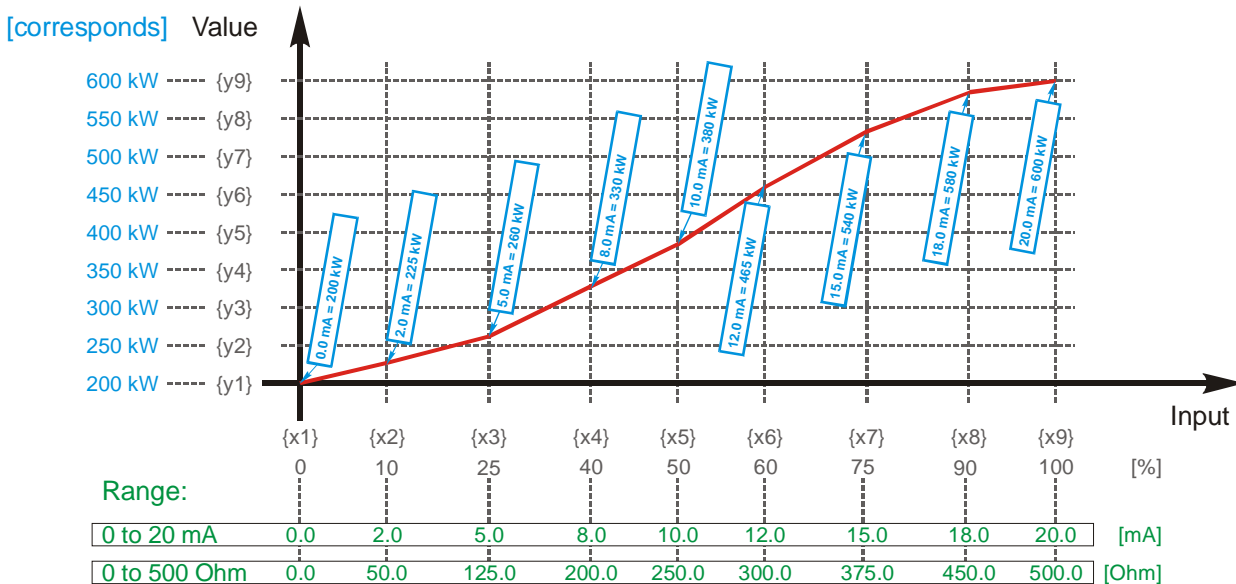

Figure 3-16: Analog input scaling - table (example)



NOTE

The X and Y junction may be moved within the range of values (the junctions don't have to be equidistant).

When configuring the X coordinates, ensure the coordinates always increase in scale continuously. In the following example the first set of x/y coordinates are correct and the second set of x/y coordinates are wrong:

- **correct** X-coord. 0 % 10 % 20 % 40 % 50 % 60 % 80 % 90 % 100 %
 Y-coordinate -100 -95 -500 -10 +3 +17 +18 +100 +2000
- **wrong** X-coord. 0 % 10 % 20 % 60 % 20 % 30 % 80 % 40 % 100 %
 Y-coordinate -100 -50 -95 +18 +17 +3 -10 +2000 +100

If the first X coordinate is >0%, all values smaller than the first X value will be output with the first Y value. If the last Y value is <100%, all higher values will be output with the value of Y9.

Parameter table

Level	Text	Setting range	Default value
Configure user defined table A / B			
Table A	X-value 1	0 to 100 %	2 %
	Y-value 1	-32000 to 32000	0
	X-value 2	0 to 100 %	8 %
	Y-value 2	-32000 to 32000	207
	X-value 3	0 to 100 %	16 %
	Y-value 3	-32000 to 32000	512
	X-value 4	0 to 100 %	24 %
	Y-value 4	-32000 to 32000	838
	X-value 5	0 to 100 %	27 %
	Y-value 5	-32000 to 32000	970
	X-value 6	0 to 100 %	31 %
	Y-value 6	-32000 to 32000	1160
	X-value 7	0 to 100 %	36 %
	Y-value 7	-32000 to 32000	1409
	X-value 8	0 to 100 %	37 %
	Y-value 8	-32000 to 32000	1461
	X-value 9	0 to 100 %	41 %
	Y-value 9	-32000 to 32000	1600
Table B	X-value 1	0 to 100 %	4 %
	Y-value 1	-32000 to 32000	2553
	X-value 2	0 to 100 %	6 %
	Y-value 2	-32000 to 32000	2288
	X-value 3	0 to 100 %	8 %
	Y-value 3	-32000 to 32000	2100
	X-value 4	0 to 100 %	13 %
	Y-value 4	-32000 to 32000	1802
	X-value 5	0 to 100 %	16 %
	Y-value 5	-32000 to 32000	1685
	X-value 6	0 to 100 %	23 %
	Y-value 6	-32000 to 32000	1488
	X-value 7	0 to 100 %	28 %
	Y-value 7	-32000 to 32000	1382
	X-value 8	0 to 100 %	42 %
	Y-value 8	-32000 to 32000	1188
	X-value 9	0 to 100 %	58 %
	Y-value 9	-32000 to 32000	1035

Table 3-70: Application - standard values - configure analog input table A / B

The following parameters are used to configure the characteristic curve. Refer to Table 3-71 for the parameter IDs of the individual parameters for all scaling points of tables A and B.

EN	X-value {a}					Table {x} [x = A/B]: X-coordinate {a} [a = 1 to 9]					0 to 100 %
DE	X-Wert {a}										
CL2	{0}	{1o}	{1oc}	{2oc}							
3560	✓	✓	✓	✓	The analog input is assigned to a curve. This parameter defines the actual percentage assigned to each of the nine points along the X-axis of the total range of the selected hardware for analog input. For example: If a 0 to 20 mA input is configured and the X1-coordinate = 0%, then the value configured for Y1 is output for an input of 0 mA.						
EN	Y-value {b}					Table {x} [x = A/B]: Y-coordinate {b} [b = 1 to 9]					-9999 to 9999
DE	Y-Wert {b}										
CL2	{0}	{1o}	{1oc}	{2oc}							
3550	✓	✓	✓	✓	This parameter defines the Y-coordinate (the displayed and monitored value) at the corresponding X-coordinate. For example: If a 0 to 20mA input is configured and the X2-coordinate = 10%, then the value configured for the Y2-coordinate is output for an input of 2 mA.						

Table 3-71 shows a complete list of the parameter IDs for the table scaling points.

Scaling point No.	1	2	3	4	5	6	7	8	9
Table A - X value	3560	3561	3562	3563	3564	3565	3566	3567	3568
Table A - Y value	3550	3551	3552	3553	3554	3555	3556	3557	3558
Table B - X value	3610	3611	3612	3613	3614	3615	3616	3617	3618
Table B - Y value	3600	3601	3602	3603	3604	3605	3606	3607	3608

Table 3-71: Analog inputs - table characteristics - parameter IDs

Analog Inputs: Inputs 1 to 3



NOTE

Monitoring of the analog inputs (overrun/underrun) must be configured manually to the flexible limits (refer to Configure Monitoring: Flexible Limits on page 122).

Parameter table

Level	Text	Setting range	Default value
Configure analog inputs 1 to 3			
	Description	<i>1 to 16 character text</i>	Analog inp. {x}
	Type	Off / VDO 5bar / VDO 10bar / VDO 150°C / VDO 120°C / Pt100 / Linear / Table A / Table B	Off
	User defined min display value	-32000 to 32000	0
	User defined max display value	-32000 to 32000	1000
	Sender value at display min.	0.00 to 100.00 %	0.00 %
	Sender value at display max.	0.00 to 100.00 %	100.00 %
	Sender type	0 - 500 Ohm / 0 - 20 mA	0 - 500 Ohm
	Offset	-20.0 to 20.0 Ohm	0.0 Ohm
	Sender connection type	Two wire / One wire	Two wire
	Monitoring wire break	Off / High / Low / High/Low	Off
	Wire break alarm class	A / B / C / D / E / F / Control	B
	Self acknowledge wire break	Yes / No	No
	Filter time constant	Off / 1 / 2 / 3 / 4 / 5	3
	Bargraph minimum	-32000 to 32000	0
	Bargraph maximum	-32000 to 32000	1000
	Value format	<i>1 to 8 character text</i>	000000

Table 3-72: Application - standard values - configure analog inputs 1 to 3

EN	Description
DE	Beschreibung
CL2	{0} {10} {10c} {20c}
T	✓ ✓ ✓ ✓
1025	
1075	
1125	

Analog input {x} [x = 1 to 3]: Message text

user-defined

The event history will store this text message and it is also displayed on the visualization screen. If the programmed limit value of the analog input has been reached or exceeded this text is displayed in the control unit screen. The text may have 1 through 16 characters.

Note: This parameter may only be configured using ToolKit.

	Type			
	{0}	{1o}	{1oc}	{2oc}
CL2	✓	✓	✓	✓
1000				
1050				
1100				

Analog input {x} [x = 1 to 3]: Type Off / VDO 5bar / VDO 10bar / VDO 150°C / VDO 120°C / Pt100 / Linear / Table A / Table B

i The characteristic curves of the inputs can be found in Appendix F (page 329).

According to the following parameters different measuring ranges are possible at the analog inputs. The selectable ranges are:

- Off** The analog input is switched off.
- VDO 5bar** The value of the analog input is interpreted with the VDO characteristics 0 to 5 bar.
- VDO 10bar** The value of the analog input is interpreted with the VDO characteristics 0 to 10 bar.
- VDO 150°C** The value of the analog input is interpreted with the VDO characteristics 50 to 150 °C.
- VDO 120°C** The value of the analog input is interpreted with the VDO characteristics 40 to 120 °C.
- Pt100** The value of the analog input is interpreted with a Pt100 characteristic.
- Linear** Each analog input may be assigned to a linear characteristic curve, which can be only used for the respective defined input [T{x}] (x = 1 to 2). The minimum (0 %) and maximum (100 %) value refers to the total measuring range of the analog input (i.e. 0 to 500 Ohm or 0 to 20 mA) or the values configured as "Sender value at display min." (parameter 1039, 1089, or 1139) and "Sender value at display max." (parameter 1040, 1090, or 1140).
- Table A / B** The analog input is assigned to a characteristic curve which is defined over 9 points (stored in a table). Two independent tables (table A and table B) may be allocated to the analog inputs. Note that if these tables are to be used with the analog inputs, the defined points of these tables must be programmed into the control unit.



NOTE

The following parameters "User defined min display value" and "User defined max display value" are only visible if the previous parameter "Type" is configured to "Linear".

	User defined min display value			
	{0}	{1o}	{1oc}	{2oc}
CL2	✓	✓	✓	✓
1001				
1051				
1101				

Analog input {x} [x = 1 to 3]: User defined minimum display value -32000 to 32000

The value to be displayed for the minimum of the input range must be entered here.

	User defined max display value			
	{0}	{1o}	{1oc}	{2oc}
CL2	✓	✓	✓	✓
1002				
1052				
1102				

Analog input {x} [x = 1 to 3]: User defined maximum display value -32000 to 32000

The value to be displayed for the maximum of the input range must be entered here.

**NOTE**

The following parameters "Sender value at display min" and "Sender value at display max" are only visible if the previous parameter "Type" is configured to "Linear", "Table A", or "Table B".

EN	Sender value at display min.				Analog input {x} [x = 1 to 3]: Source value at display minimum	0.00 to 100.00 %
DE	Quellwert bei min Anzeige					
CL2	{0}	{1o}	{1oc}	{2oc}	The value of the configured input range, which shall correspond with the minimum value configured for the display, must be entered here. This specifies the lower limit of the hardware range to be measured.	
1039	✓	✓	✓	✓		
1089						
1139						

Example: If the input range is 0 to 20 mA where 0 mA corresponds with 0 % and 20 mA corresponds with 100 %, and the value configured here is 20 %, an analog input value of 4 mA would correspond with the minimum value configured for the display.

EN	Sender value at display max.				Analog input {x} [x = 1 to 3]: Source value at display maximum	0.00 to 100.00 %
DE	Quellwert bei max Anzeige					
CL2	{0}	{1o}	{1oc}	{2oc}	The value of the configured input range, which shall correspond with the maximum value configured for the display, must be entered here. This specifies the upper limit of the hardware range to be measured.	
1040	✓	✓	✓	✓		
1090						
1140						

Example: If the input range is 0 to 500 Ohm where 0 Ohm corresponds with 0 % and 500 Ohm corresponds with 100 %, and the value configured here is 36 %, an analog input value of 180 Ohm would correspond with the maximum value configured for the display.

**NOTE**

The following parameter "Sender type" must be configured to "0 to 500 Ohm", if "Type" (parameter 1000, 1050, or 1100) is configured to "VDO xx" or "Pt100".

EN	Sender type				Analog input {x} [x = 1 to 3]: Hardware	0 to 500 Ohm / 0 to 20 mA
DE	Auswahl Hardware					
CL2	{0}	{1o}	{1oc}	{2oc}	The software in the control unit may be configured for various types of sensors. The configurable ranges apply to the linear analog input. Configurable ranges are: 0 to 500 Ohm The measuring range of the analog input is 0- to 500 Ohm. 0 Ohm = 0 %, 500 Ohm = 100 %. 0 to 20 mA ... The measuring range of the analog input is 0 to 20 mA. 0 mA = 0 %, 20 mA = 100 %.	
1020	✓	✓	✓	✓		
1070						
1120						



NOTE

The following parameters "Offset" and "Sender connection type" are only visible if the previous parameter "Sender type" is configured to "0 to 500 Ohm".

EN	Offset			
DE	Offset			
CL2	{0}	{1o}	{1oc}	{2oc}
1046	✓	✓	✓	✓
1096				
1146				

Analog input {x} [x = 1 to 3]: Offset **-20.0 to 20.0 Ohm**

The resistive input (the "0 to 500Ohm" analog input) may be calculated with a permanent offset to adjust for inaccuracies. If the offset feature is utilized, the value configured in this parameter will be added to/subtracted from the measured resistive value. This has the following effect to the measured values (please note tables starting on page 329):

-20.0 to 0.1 Ohm

VDO temperature: The displayed value will decrease.

VDO pressure: The displayed value will increase.

+0.1 to 20.0 Ohm

VDO temperature: The displayed value will increase.

VDO pressure: The displayed value will decrease.

EN	Sender connection type			
DE	Anschluß Typ			
CL2	{0}	{1o}	{1oc}	{2oc}
1041	✓	✓	✓	✓
1091				
1141				

Analog input {x} [x = 1 to 3]: Connection type **Two-pole / Single-pole**

This parameter defines the type of the used sender. Refer to the Installation Manual 37426 for wiring details.

Two-poleA two-wire sender is connected to the easYgen. The unit measures the sender values between the dedicated terminals.

Single-pole ...A one-wire sender is connected to the easYgen. The unit measures the sender values between the terminal of the analog input and the engine ground terminal.

The respective analog input is monitored for wire break.

If this protective function is triggered, the display indicates "Wb: {Text of Parameter [Description]}" (parameter 1025/1075/1125 on page 161).

EN	Monitoring wire break			
DE	Drahtbruchüberw.			
CL2	{0}	{1o}	{1oc}	{2oc}
1003	✓	✓	✓	✓
1053				
1103				

Analog input {x} [x = 1 to 3] wire break monitoring **Off / High / Low / High/Low**

The analog input can be monitored for a wire break. The following configurations are used to monitor for a wire break:

OffNo wire break monitoring is performed.

High.....If the actual value rises over the maximum value (overshoot), this is identified as a wire break.

Low.....If the actual value falls below the minimum value (undershoot), this is identified as a wire break.

High/LowIf the actual value rises over the maximum value (overshoot) or falls below the minimum value (undershoot), this is identified as a wire break.



NOTE

Monitoring of the analog inputs (overrun/underrun) must be configured manually to the flexible limits (refer to Configure Monitoring: Flexible Limits on page 122).

If the control unit detects that the measuring range for an analog input has been exceeded and an alarm is issued, the limit value monitoring of this analog input is disabled and an error message is displayed.

The measuring range is recognized as being exceeded and an alarm is issued:

- 0 to 20 mA
 - Minimum value2 mA.....Undershooting
 - Maximum value.....20.5 mA.....Overshooting
- 0 to 500 Ohm
 - Minimum value5 OhmUndershooting (Offset = 0 Ohm)
 - Maximum value.....515 OhmOvershooting (Offset = 0 Ohm)

Note: Depending on what was configured for the offset value (parameter 1046/1096/1146 on page 164) the displayed value may be shifted. This may result in a broken wire being recognized early or later than the actual value being measured. (An offset of +20ohms will recognize a wire break at 25ohms instead of 5ohms.)



NOTE

A wire break is indicated in ToolKit by displaying an analog input value of 3276.6.



NOTE

The following two parameters are only visible, if wire break monitoring (parameter 1003/1053/1103 on page 164) is not configured Off.

EN	Wire break alarm class	Analog in. {x} [x = 1 to 3]: Alarm class wire break monit.	Class A/B/C/D/E/F/Control
DE	Drahtbruch Alarmklasse		
CL2	{0} {1o} {1oc} {2oc}	ⓘ See chapter "Alarm" on page 271.	
1004	✓ ✓ ✓ ✓		
1054			
1104			

Each limit may be assigned an independent alarm class that specifies what action should be taken when the limit is surpassed.

EN	Self acknowledge wire break	Analog input {x} [x = 1 to 3]: Self acknowledged	Yes / No
DE	Drahtbruch selbstquitt.		
CL2	{0} {1o} {1oc} {2oc}	Yes	The control automatically clears the alarm if the fault condition is no longer detected.
1005	✓ ✓ ✓ ✓	No	The control does not automatically reset the alarm when the fault condition is no longer detected. The alarm must be acknowledged and reset by manually pressing the appropriate buttons or by activating the <i>LogicsManager</i> output "External acknowledgement" (via a discrete input or via an interface).
1055			
1105			

		Filter time constant			
		Filter			
CL2	{0}	{1o}	{1oc}	{2oc}	
10113	✓	✓	✓	✓	
10114					
10116					

Analog input {x} [x = 1 to 3]: Filter time constant Off / 1 / 2 / 3 / 4 / 5

A filter time constant may be used to reduce the fluctuation of an analog input reading. This filter time constant assesses the average of the signal according to the following formula:

$$\text{Cut-off frequency} = \frac{1}{20ms \times 2 \times \pi \times 2^{N-1}}$$

whereby "N" is the parameter.

- OffThe analog input is displayed without filtering.
- 1Cut-off-frequency = 7.96 Hz (filter time constant = 0.02 s)
- 2Cut-off-frequency = 3.98 Hz (filter time constant = 0.04 s)
- 3Cut-off-frequency = 1.99 Hz (filter time constant = 0.08 s)
- 4Cut-off-frequency = 0.99 Hz (filter time constant = 0.16 s)
- 5Cut-off-frequency = 0.50 Hz (filter time constant = 0.32 s)

		Bargraph minimum			
		Bargraph Minimum			
CL2	{0}	{1o}	{1oc}	{2oc}	
3632	✓	✓	✓	✓	
3634					
3636					

Analog input {x} [x = 1 to 3]: Bar graph minimum value -9999 to 9999

The start value for the bar graph display of the analog input is defined here. The value must be entered according to the display format, which refers to the analog input type (parameter 1000 on page 162).

Note: This parameter is only effective if parameter 1000 is configured to Linear or Table A/B.

		Bargraph maximum			
		Bargraph Maximum			
CL2	{0}	{1o}	{1oc}	{2oc}	
3633	✓	✓	✓	✓	
3635					
3637					

Analog input {x} [x = 1 to 3]: Bar graph maximum value -9999 to 9999

The end value for the bar graph display of the analog input is defined here. The value must be entered according to the display format, which refers to the analog input type (parameter 1000 on page 162).

Note: This parameter is only effective if parameter 1000 is configured to Linear or Table A/B.

	Value format			
DE	Zahlenformat			
CL2	{0}	{1o}	{1oc}	{2oc}
T	✓	✓	✓	✓
1035				
1085				
1135				

Analog input {x} [x = 1 to 3]: Value format

user-defined

① If a sign to denote a negative measured value (i.e. -10) is required, then the first "0" of the numeric display is utilized for this symbol.

To display the measuring value of the analog input for the analog input types linear as well as Table A and Table B (parameter 1000 on page 162) correctly this parameter is to be used to define the format. The zeros in the numeric display are used for the measuring values and are configurable. The placeholders for the digits may have symbols (i.e. commas).

Note

- This parameter may only be configured using ToolKit.
- This parameter only applies to the linear and the user defined Table A and Table B (parameter 1000 on page 162) analog input types.
- The displayed value should be configured with the same number of digits as the desired value to be measured.
- The measured value will be displayed from right to left. If the measured value is larger than the number of digits in the display, only a portion of the measured value will be shown. An example of this would be a display of three digits is configured when four digits will be needed. Instead of the number "1234" being displayed only "234" will be shown.

Examples

Fuel level - value at 0 %0
 - value at 100 %1000
 - desired displayup to 1,000mm
 - this parameter.....0,000mm

Angle - value at 0 %-1799
 - value at 100 %1800
 - desired display-179.9° to 180.0°
 - this parameter.....0000.0°

Pressure - value at 0 %0
 - value at 100 %100
 - desired displayup to 10.0bar
 - this parameter.....00.0bar

Note

- If the analog input type (parameter 1000 on page 162) is configured to VDO or Pt100, the following formats apply:
 VDO 5 bar display in 0.01 bar – example: 5.0 bar > ToolKit display: 50,0
 VDO 10 bar display in 0.01 bar – example: 6.6 bar > ToolKit display: 66,0
 VDO 120°C display in °C – example: 69°C > ToolKit display: 6,9
 VDO 150°C display in °C – example: 73°C > ToolKit display: 7,3
 Pt100 display in °C – example: 103°C > ToolKit display: 10,3

Configure Discrete Inputs

Number	Terminal	Application mode			
		{0}	{1o}	{1oc}	{2oc}
Internal discrete inputs, board #1					
[DI1]	44	Alarm input (<i>LogicsManager</i>); pre-configured for 'Emergency Stop'			
[DI2]	45	Control input (<i>LogicsManager</i>); pre- configured for 'Start request in AUTO'			
[DI3]	46	Alarm input (<i>LogicsManager</i>); pre- configured for 'Low oil pressure'			
[DI4]	47	Alarm input (<i>LogicsManager</i>); pre- configured for 'Coolant temperature'			
[DI5]	48	Control input (<i>LogicsManager</i>); pre- configured for 'External acknowledgement'			
[DI6]	49	Control input (<i>LogicsManager</i>); pre- configured for 'Release MCB'			
[DI7]	50	Reply MCB			
[DI8]	51	Reply GCB			
[DI9]	76	Alarm input (<i>LogicsManager</i>)			
[DI10]	77	Alarm input (<i>LogicsManager</i>)			

Table 3-73: Discrete inputs - terminal assignment

NOTE
 Alarm inputs may also be configured as control inputs and then be used as command variables in the *LogicsManager*.

Discrete inputs may be configured to normally open (N.O.) or normally closed (N.C.) states. In the state N.O., no potential is present during normal operation; if an alarm is issued or control operation is performed, the input is energized. In the state N.C., a potential is continuously present during normal operation; if an alarm is issued or control operation is performed, the input is de-energized.

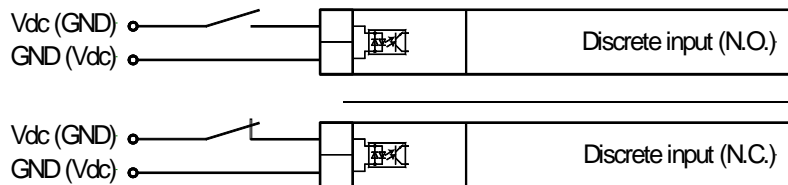

Figure 3-17: Discrete inputs - alarm/control inputs - operation logic

NOTE
 All reply messages from breakers are evaluated as N.C.

Parameter table

Level	Text	Setting range	Default value
Configure discrete inputs 1 to 10			
	Text	4 to 16 character text	see parameter list
	Operation	N.O. / N.C.	N.O.
	Delay	0.08 to 650.00 s	0.20 s
	Alarm class	A / B / C / D / E / F / Control	B
	Delayed by engine speed	Yes / No	No
	Self acknowledge	Yes / No	No

Table 3-74: Application - standard values - configure discrete inputs

NOTE
 The DIs 1 to 5 are pre-configured to various functions and differ in their default values. However, they may still be configured freely. The DIs 7 & 8 are always used for the circuit breaker replies and cannot be configured.

EN	DI {x} Text			
DE	DI {x} Text			
CL2	{0}	{1o}	{1oc}	{2oc}
T	✓	✓	✓	✓
1400				

Discrete input: Message text

user-defined

If the discrete input is enabled with alarm class, this text is displayed on the control unit screen. The event history will store this text message as well. The text may have 4 through 16 characters.

Note: This parameter may only be configured using ToolKit.

Note: If the DI is used as control input with the alarm class "Control", you may enter here its function (e.g. external acknowledgement) for a better overview within the configuration.

EN	DI {x} Operation			
DE	DI {x} Funktion			
CL2	{0}	{1o}	{1oc}	{2oc}
1201	✓	✓	✓	✓

Discrete input: Operation

N.O. / N.C.

The discrete inputs may be operated by an normally open (N.O.) or normally closed (N.C.) contact. The idle circuit current input can be used to monitor for a wire break. A positive or negative voltage polarity referred to the reference point of the DI may be applied.

N.O. The discrete input is analyzed as "enabled" by energizing the input (normally open).

N.C...... The discrete input is analyzed as "enabled" by de-energizing the input (normally closed).

EN	DI {x} Delay			
DE	DI {x} Verzögerung			
CL2	{0}	{1o}	{1oc}	{2oc}
1200	✓	✓	✓	✓

Discrete input: Delay

0.08 to 650.00 s

A delay time in seconds can be assigned to each alarm or control input. The discrete input must be enabled without interruption for the delay time before the unit reacts. If the discrete input is used within the *LogicsManager* this delay is taken into account as well.

EN	DI {x} Alarm class			
DE	DI {x} Alarmlasse			
CL2	{0}	{1o}	{1oc}	{2oc}
1202	✓	✓	✓	✓

Discrete input: Alarm class

Class A/B/C/D/E/F/Control

ⓘ see chapter "Alarm Classes" on page 271.

An alarm class may be assigned to the discrete input. The alarm class is executed when the discrete input is enabled.

If "control" has been configured, there will be no entry in the event history and a function out of the *LogicsManager* (description at page 272) can be assigned to the discrete input.

EN	DI {x} Delayed by engine speed			
DE	DI {x} Verzögert durch Motordr.			
CL2	{0}	{1o}	{1oc}	{2oc}
1203	✓	✓	✓	✓

Discrete input: Engine delayed monitoring

Yes / No

Yes Monitoring for fault conditions is not performed until engine delayed monitoring is enabled. The engine monitoring delay time (parameter 3315 on page 186) must expire prior to fault monitoring being enabled for parameters assigned this delay.

No Monitoring for this fault condition is continuously enabled regardless of engine speed.

EN	DI {x} Self acknowledge			
DE	DI {x} Selbstquittierend			
CL2	{0}	{1o}	{1oc}	{2oc}
1204	✓	✓	✓	✓

Discrete input: Self acknowledgment Yes / No

Yes.....The control automatically clears the alarm if the fault condition is no longer detected.

No.....The control does not automatically reset the alarm when the fault condition is no longer detected. The alarm must be acknowledged and reset by manually pressing the appropriate buttons or by activating the *LogicsManager* output "External acknowledgement" (via a discrete input or via an interface).

If the DI is configured with the alarm class "Control", self acknowledgement is always active.



NOTE

If a discrete input has been configured with a shut-down alarm that has been enabled to self-acknowledge, and has been configured as engine delayed the following scenario may happen:

- The discrete input shuts down the engine because of its alarm class.
- Due to the engine stopping, all engine delayed alarms are ignored.
- The alarm class is acknowledged automatically.
- The alarm will self-acknowledge and clear the fault message that shut the engine down. This prevents the fault from being analyzed. After a short delay, the engine will restart.
- After the engine monitoring delay expires, the fault that originally shut down the engine will do so again. This cycle will continue to repeat until corrected.

The preceding parameters are used to configure the discrete inputs 1 through 10. The parameter IDs refer to DI 1. Refer to Table 3-75 for the parameter IDs of the parameters DI 2 through DI 10.

	DI 1	DI 2	DI 3	DI 4	DI 5	DI 6	DI 9	DI 10
Text	1400	1410	1420	1430	1440	1450	1480	1488
Operation	1201	1221	1241	1261	1281	1301	1361	1381
Delay	1200	1220	1240	1260	1280	1300	1360	1380
Alarm class	1202	1222	1242	1262	1282	1302	1362	1382
Delayed by engine speed	1203	1223	1243	1263	1283	1303	1363	1383
Self acknowledged	1204	1224	1244	1264	1284	1304	1364	1384

Table 3-75: Discrete inputs - parameter IDs



NOTE

The DIs 7 & 8 are always used for the circuit breaker replies and cannot be configured.

Configure External Discrete Inputs

If a Woodward IKD 1 or other external expansion board (Phoenix Contact) is connected to the easYgen via the CAN bus, it is possible to use 16 additional discrete inputs.

The configuration of these external DIs is performed in a similar way like for the internal DIs. Refer to Table 3-77 for the parameter IDs of the parameters for external DIs 1 through 16.

Parameter table

Level	Text	Setting range	Default value
Configure external discrete inputs 1 to 16 {x}			
	Text	<i>4 to 16 character text</i>	Ext. DI {x}
	Operation	N.O. / N.C.	N.O.
	Delay	0.05 to 650.00 s	0.20 s
	Alarm class	A / B / C / D / E / F / Control	Control
	Delayed by engine speed	Yes / No	No
	Self acknowledge	Yes / No	No

Table 3-76: Application - standard values - configure discrete inputs

External	DI 1	DI 2	DI 3	DI 4	DI 5	DI 6	DI 7	DI 8
Text	16200	16210	16220	16230	16240	16250	16260	16270
Operation	16001	16011	16021	16031	16041	16051	16061	16071
Delay	16000	16010	16020	16030	16040	16050	16060	16070
Alarm class	16002	16012	16022	16032	16042	16052	16062	16072
Delayed by engine speed	16003	16013	16023	16033	16043	16053	16063	16073
Self acknowledged	16004	16014	16024	16034	16044	16054	16064	16074
External	DI 9	DI 10	DI 11	DI 12	DI 13	DI 14	DI 15	DI 16
Text	16280	16290	16300	16310	16320	16330	16340	16350
Operation	16081	16091	16101	16111	16121	16131	16141	16151
Delay	16080	16090	16100	16110	16120	16130	16140	16150
Alarm class	16082	16092	16102	16112	16122	16132	16142	16152
Delayed by engine speed	16083	16093	16103	16113	16123	16133	16143	16153
Self acknowledged	16084	16094	16104	16114	16124	16134	16144	16154

Table 3-77: External discrete inputs - parameter IDs

Discrete Outputs (*LogicsManager*)

The discrete outputs are controlled via the *LogicsManager*.

⇒ Please note the description of the *LogicsManager* starting on page 273.

Some outputs are assigned a function according to the application mode (see following table).

Relay Number	Term.	Application mode			
		None {0}	GCB open {1o}	GCB open/close {1oc}	GCB/MCB open/close {2oc}
Internal relay outputs					
[R1]	30/31	<i>LogicsManager</i> ; pre-assigned with 'Ready for operation OFF'			
[R2]	32/33	<i>LogicsManager</i> ; pre-assigned with 'Centralized alarm (horn)'			
[R3]	34/35	<i>LogicsManager</i> ; pre-assigned with 'Starter'			
[R4]	36/37	<i>LogicsManager</i> ; pre-assigned with 'Diesel: Fuel solenoid, Gas: Gas valve'			
[R5]	38/39/40	<i>LogicsManager</i> ; pre-assigned with 'Warning alarm'			Command: open MCB
[R6]	41/42	<i>LogicsManager</i>		Command: close GCB	
[R7]	80/81	<i>LogicsManager</i>	Command: open GCB		
[R8]	82/83	<i>LogicsManager</i> ; pre-assigned with 'Mains decoupling'			Command: close MCB
[R9]	84/85	<i>LogicsManager</i> ; pre-assigned with 'Stop solenoid'			
[R10]	86/87	<i>LogicsManager</i> ; pre-assigned with 'Auxiliary services'			
[R11]	88/89	<i>LogicsManager</i> ; pre-assigned with 'Shut down alarm'			

Table 3-78: Relay outputs - assignment

EN	Ready for op. Off			
DE	Betriebsbe abgef.			
CL2	{0}	{1o}	{1oc}	{2oc}
12580	✓	✓	✓	✓

Digital outputs: *LogicsManager* for Ready for operation OFF *LogicsManager*

The "Ready for operation OFF" relay is energized by default if the power supply exceeds 8 V. Once the conditions of the *LogicsManager* have been fulfilled, the relay will be de-energized. This *LogicsManager* output may be configured with additional conditions, which may signal a PLC an "out of operation" condition by de-energizing the relay on terminals 41/42, like "shutdown alarm" or No "AUTO mode" present. The *LogicsManager* and its default settings are explained on page 273 in Appendix B: "*LogicsManager*".



CAUTION

The discrete output "Ready for operation OFF" must be wired in series with an emergency stop function. This means that it must be ensured that the generator circuit breaker is opened and the engine is stopped if this discrete output is de-energized. We recommend to signal this fault independently from the unit if the availability of the plant is important.

EN	Relay {x}			
DE	Relais {x}			
CL2	{0}	{1o}	{1oc}	{2oc}
12110	✓	✓	✓	✓

Digital outputs: *LogicsManager* for relay {x} *LogicsManager*

Once the conditions of the *LogicsManager* have been fulfilled, the relay will be energized. The *LogicsManager* and its default settings are explained on page 273 in Appendix B: "*LogicsManager*".

Above parameter IDs refers to R 2. Refer to Table 3-79 for the parameter IDs of the parameters for R 3 to R 11.

	R 1	R 2	R 3	R 4	R 5	R 6	R 7	R 8	R 9	R 10	R 11
Parameter ID	12580	12110	12310	12320	12130	12140	12150	12160	12170	12180	12560

Table 3-79: Discrete outputs - parameter IDs

External Discrete Outputs (*LogicsManager*)

If a Woodward IKD 1 or other external expansion board (Phoenix Contact) is connected to the easYgen via the CAN bus, it is possible to use 16 additional discrete outputs.

The configuration of these external DOs is performed in a similar way like for the internal DOs. Refer to Table 3-80 for the parameter IDs of the parameters for external DOs 1 through 16.

	DO 1	DO 2	DO 3	DO 4	DO 5	DO 6	DO 7	DO 8
Parameter ID	12330	12340	12350	12360	12370	12380	12390	12400
	DO 9	DO 10	DO 11	DO 12	DO 13	DO 14	DO 15	DO 16
Parameter ID	12410	12420	12430	12440	12450	12460	12470	12480

Table 3-80: External discrete outputs - parameter IDs

Configure Analog Outputs

Configure Analog Outputs 1/2

The analog outputs 1 and 2 may either be configured as analog or PWM outputs. The analog outputs are prepared for speed and voltage bias signal for a speed controller and voltage regulator with an output signal of 0 to 20 mA / 0 to 10 V by default. Table 3-81 shows the default values for the analog outputs 1 and 2 as well as two configuration examples. Example 1 is for a generator active power output with a range of -20 kW to 220 kW via a 4 to 20 mA signal (generator rated power = 200 kW). Example 2 is for a speed bias output via a PWM signal.

	ID	Analog Output 1 default values	ID	Analog Output 2 default values	Example 1	Example 2
Data source	5200	00.03 Speed bias	5214	00.02 Voltage bias	01.24 Gen. total power	00.03 Speed bias
Source value at minimal output	5204	0	5218	0	-1000 (-20 kW)	0
Source value at maximal output	5206	10000	5220	10000	11000 (220 kW)	10000
Filter time constant	5203	Off	5217	Off	3	Off
Selected hardware type	5201	0-20mA / 0-10V	5215	0-20mA / 0-10V	User defined	User defined
User defined min. output value	5208	---	5222	---	60.00 % (4 mA)	0.00 %
User defined max. output value	5209	---	5223	---	100.00 % (20 mA)	100.00 %
PWM signal	5202	Off	5216	Off	Off	On
PWM output value	5210	---	5224	---	---	6 V

Table 3-81: Analog outputs 1/2 - parameter table



NOTE

To get the standard PWM signal it is necessary to set parameter 5201 (Selected hardware type) to "user defined". If this parameter is configured to "user defined", the range is limited by parameters 5208 (User defined min. output value) and 5209 (User defined max. output value). Parameters 5208 and 5209 don't have a meaning unless parameter 5201 is set to "user defined".

Parameter table

Level	Text	Setting range	Default value
Configure analog outputs 1 / 2			
	Data source	<i>Analogmanager</i>	<i>refer to Table 3-81</i>
	Source value at minimal output	-32000 to 32000	0
	Source value at maximal output	-32000 to 32000	10000
	Filter time constant	Off / 1 / 2 / 3 / 4 / 5 / 6 / 7	Off
	Selected hardware type	<i>refer to Table 3-85</i>	0-20mA / 0-10V
	User defined min. output value	0.00 to 100.00 %	0.00 %
	User defined max. output value	0.00 to 100.00 %	100.00 %
	PWM signal	On / Off	Off
	PWM output level	0.00 to 10.00 V	10.00 V

Table 3-82: Application - standard values - configure analog outputs 1/2

Configure Analog Outputs 3/4

In comparison to the analog outputs 1 and 2 are the outputs 3 and 4 purely prepared to 0/4 to 20 mA. The outputs are freely scalable. Each analog source of the analog manager can be passed to this outputs.

	ID	Analog Output 3 default values	ID	Analog Output 4 default values
Data source	5228	00.01 Engine Speed	5242	00.01 Engine Speed
Source value at minimal output	5232	0	5246	0
Source value at maximal output	5234	10000	5248	10000
Filter time constant	5231	3	5245	3
Selected hardware type	5229	Off	5243	Off
User defined min. output value	5236	---	5250	---
User defined max. output value	5237	---	5251	---

Table 3-83: Analog outputs 3/4 - parameter table

Parameter table

Level	Text	Setting range	Default value
Configure analog outputs 1 / 2			
	Data source	<i>Analogmanager</i>	<i>refer to Table 3-83</i>
	Source value at minimal output	-32000 to 32000	0
	Source value at maximal output	-32000 to 32000	10000
	Filter time constant	Off / 1 / 2 / 3 / 4 / 5 / 6 / 7	3
	Selected hardware type	<i>refer to Table 3-85</i>	0
	User defined min. output value	0.00 to 100.00 %	0.00 %
	User defined max. output value	0.00 to 100.00 %	100.00 %

Table 3-84: Application - standard values - configure analog outputs 3/4



NOTE

When a burden of 500 Ohm is applied to the analog outputs 3 and 4, the hardware type for voltage can also be used.

EN	Data source			
DE	Datenquelle			
CL2	{0}	{1o}	{1oc}	{2oc}
5200	✓	✓	✓	✓
5214				
5228				
5242				

Analog output {x} [x = 1 to 4]: Data source

refer to text below

The data source may be selected from the available data sources. Use the "+" and "-" softkeys to scroll through the list of sources and confirm your selection with the Enter softkey. Refer to Appendix C on page 307 for a list of all data sources.



Figure 3-18: Monitoring - analog outputs - data source selection

EN	Source value at minimal output			
DE	Quellwert bei Min-Ausgabe			
CL2	{0}	{1o}	{1oc}	{2oc}
5204	✓	✓	✓	✓
5218				
5232				
5246				

Analog output {x} [x = 1 to 4]: Source value at minimal output

-32000 to 32000

The value from the data source must exceed the value configured here to raise the output signal above 0 %. Negative percentage values may be used to change the sign, e.g. for power.

The entry format of the value depends on the selected data source. If the monitored analog value has a reference value (refer to Appendix C: Reference Values on page 312), the threshold is expressed as a percentage of this reference value (-320.00 % to 320.00 %). If an analog input is monitored, the threshold refers to the display value format (refer to Appendix C: Display Value Format on page 319 for more information).

EN	Source value at maximal output			
DE	Quellwert bei Max-Ausgabe			
CL2	{0}	{1o}	{1oc}	{2oc}
5206	✓	✓	✓	✓
5220				
5234				
5248				

Analog output {x} [x = 1 to 4]: Source value at maximal output

-32000 to 32000

If the value from the data source reaches the value configured here, the output signal will reach 100 %. Negative percentage values may be used to change the sign, e.g. for power.

The entry format of the value depends on the selected data source. If the monitored analog value has a reference value (refer to Appendix C: Reference Values on page 312), the threshold is expressed as a percentage of this reference value (-320.00 % to 320.00 %). If an analog input is monitored, the threshold refers to the display value format (refer to Appendix C: Display Value Format on page 319 for more information).

DE	EN	Filter time constant			
		{0}	{1o}	{1oc}	{2oc}
CL2		✓	✓	✓	✓
5203					
5217					
5231					
5245					

Analog output {x} [x = 1 to 4]: Filter time constant Off / 1 / 2 / 3 / 4 / 5 / 6 / 7

A filter time constant may be used to reduce the fluctuation of an analog output value. This filter time constant assesses the average of the signal according to the following formula:

$$\text{Cut-off frequency} = \frac{1}{20ms \times 2 \times \pi \times 2^{N-1}}$$

, whereby "N" is the parameter.

- Off**..... The analog output is displayed without filtering.
- 1..... Cut-off-frequency = 7.96 Hz (filter time constant = 0.02 s)
 - 2..... Cut-off-frequency = 3.98 Hz (filter time constant = 0.04 s)
 - 3..... Cut-off-frequency = 1.99 Hz (filter time constant = 0.08 s)
 - 4..... Cut-off-frequency = 0.99 Hz (filter time constant = 0.16 s)
 - 5..... Cut-off-frequency = 0.50 Hz (filter time constant = 0.32 s)
 - 6..... Cut-off-frequency = 0.25 Hz (filter time constant = 0.64 s)
 - 7..... Cut-off-frequency = 0.13 Hz (filter time constant = 1.28 s)

Note: The filter is not applied to the analog output display value, i.e. the end value of the analog output is displayed immediately.

DE	EN	Selected hardware type			
		{0}	{1o}	{1oc}	{2oc}
CL2		✓	✓	✓	✓
5201					
5215					
5229					
5243					

Analog output {x} [x = 1 to 4]: Selected hardware type select from list below

This parameter is used to configure the appropriate type of analog controller signal. The range of the analog output is configured here. The available ranges are listed below. It is possible to configure the following settings:

Off..... No analog output signal will be issued.
user defined. A maximum range of +/-20 mA / +/-10 V may be limited using the parameters 5208 and 5209 on page 177 to obtain a user defined range.

Type	Setting in above configuration screen	Jumper necessary	Range	Lower level	Upper level
Current	+/-20mA (+/-10V)	no	+/-20mA	-20 mA	+20 mA
	+/-10mA (+/-5V)		+/-10mA	-10 mA	+20 mA
	0 to 10mA (0 to 5V)		0-10mA	0 mA	10 mA
	0 to 20mA (0 to 10V)		0-20mA	0 mA	20 mA
	4 to 20mA		4-20mA	4 mA	20 mA
	10 to 0mA (5 to 0V)		10-0mA	10 mA	0 mA
	20 to 0mA (10 to 0V)		20-0mA	20 mA	0 mA
	20 to 4mA		20-4mA	20 mA	4 mA
Voltage	+/-20mA (+/-10V)	yes	+/-10V	-10 Vdc	+10 Vdc
	+/-10mA (+/-5V)		+/-5V	-5 Vdc	+5 Vdc
	+/-3V		+/-3V	-3 Vdc	+3 Vdc
	+/-2.5V		+/-2.5V	-2.5Vdc	+2.5 Vdc
	+/-1V		+/-1V	-1 Vdc	+1 Vdc
	0 to 10mA (0 to 5V)		0 to 5V	0 Vdc	5 Vdc
	0.5V to 4.5V		0.5 to 4.5V	0.5 Vdc	4.5 Vdc
	0 to 20mA (0 to 10V)		0 to 10V	0 Vdc	10 Vdc
	10 to 0mA (5 to 0V)		5 to 0V	5 Vdc	0 Vdc
	4.5V to 0.5V		4.5 to 0.5V	4.5 Vdc	0.5 Vdc
	20 to 0mA (10 to 0V)		10 to 0V	10 Vdc	0 Vdc

Table 3-85: Analog outputs - signal type selection

EN	User defined min. output value			
DE	Frei definierbares Min-Signal			
CL2	{0}	{1o}	{1oc}	{2oc}
5208	✓	✓	✓	✓
5222				
5236				
5250				

Analog output {x} [x = 1 to 4]: User defined minimum output value 0 to 100 %

The minimum output value, which shall correspond with the minimum value of the output range, must be entered here. This parameter is only active, if parameter 5201 on page 176 is configured to "user defined".

Example: If the value configured here is 25 %, the maximum output range of +/- 20 mA / +/-10 V has a lower limit of -10 mA / -5 V.

EN	User defined max. output value			
DE	Frei definierbares Max-Signal			
CL2	{0}	{1o}	{1oc}	{2oc}
5209	✓	✓	✓	✓
5223				
5237				
5251				

Analog output {x} [x = 1 to 4]: User defined maximum output value 0 to 100 %

The maximum output value, which shall correspond with the maximum value of the output range, must be entered here. This parameter is only active, if parameter 5201 on page 176 is configured to "user defined".

Example: If the value configured here is 75 %, the maximum output range of +/- 20 mA / +/-10 V has an upper limit of 10 mA / 5 V.

EN	PWM signal			
DE	PWM Signal			
CL2	{0}	{1o}	{1oc}	{2oc}
5202	✓	✓	✓	✓
5216				

Analog output {x} [x = 1 to 2]: PWM signal On / Off

On.....A PWM signal will be output on the respective analog output. The amplitude of the PWM signal to be utilized is configured in "PWM output level" (parameter 5210 on page 177). If a PWM signal is used, a jumper must be installed (refer to the wiring diagram in manual 37426). The PWM signal will also be limited by parameter 5201 on page 176 or parameters 5208 and 5209 on page 177 if parameter 5201 is user defined.

Off.....An analog signal will be output on the respective analog output.

EN	PWM output level			
DE	PWM Ausgangslevel			
CL2	{0}	{1o}	{1oc}	{2oc}
5210	✓	✓	✓	✓
5224				

Analog output {x} [x = 1 to 2]: PWM output level 0.00 to 10.00 V

If PWM has been enabled in parameter 5203 on page 176, the level of the PWM signal may be adjusted here.

Configure Application: Configure Engine

Configure Application: Configure Engine, Engine Type

Parameter table

Level	Text	Setting range	Default value
Configure engine type			
	Start/Stop mode logic	Diesel / Gas / External	Diesel
	Preglow time	0 to 999 s	5 s
	Preglow mode	Always / Analog / Off	Always
	Preglow criterion	Analogmanager	06.01
	Preglow temperature threshold	-10 to 250 °C	0 °C
	Ignition delay	1 to 999 s	5 s
	Gas valve delay	0 to 999 s	5 s
	Minimum speed for ignition	10 to 1800 rpm	100 rpm

Table 3-86: Application - standard values - configure engine type



NOTE

All functions which are described in the following text, may be assigned by the **LogicsManager** to any relay that is available via the **LogicsManager** and not assigned to another function.

EN	Start/Stop mode logic
DE	Start/Stop Modus
CL2	{0} {1o} {1oc} {2oc}
3321	✓ ✓ ✓ ✓

Engine: Type of engine

Diesel / Gas / External

Diesel or gas engine start/stop logic must be selected. The starting sequences are described in the following sections. If this parameter is configured to "External" the start/stop sequence must be done externally.

Engine: Diesel Engine

Start sequence

The relay "Preglow" will be energized for the preheating time period ("Preglow" is displayed). Following preheating, the fuel solenoid is first energized and then the starter is engaged ("Start" is displayed). When the configured firing speed is exceeded, the starter is disengaged and the fuel solenoid remains energized via the firing speed. "Ramp to rated" is displayed until the engine monitoring delay timer expires and the start sequence has finished.

If the engine fails to start, a start pause is initiated ("Start - Pause" is displayed). If the number of unsuccessful start attempts reaches the configured value, an alarm message will be issued ("Start fail" is displayed).

Stop sequence

After opening the GCB, the coasting time starts and the engine runs without load ("Cool down" is displayed). On termination of the coasting time, the fuel solenoid is de-energized, and the engine is stopped ("Stop engine" is displayed). If the engine cannot be stopped via the fuel solenoid, the alarm message "Eng. stop malfunct." is displayed.

Start/stop diagram

The formula signs and indices mean:

- t_{PRE} Auxiliary services prerun [s] (parameter 3300 on page 188)
- t_{PH} Preglow time [s] (parameter 3308 on page 179)
- t_{ST} Starter time [s] (parameter 3306 on page 184)
- t_{SP} Start pause [s] (parameter 3307 on page 184)
- t_{ED} Engine delayed monitoring [s] (parameter 3315 on page 186)
- t_{POST} Auxiliary services postrun [s] (parameter 3301 on page 188)
- t_{CD} Cool down time [s] (parameter 3316 on page 187)
- t_{GS} Generator stable time [s] (parameter 3415 on page 153)

EN	Preglow time			
DE	Vorglühzeit			
CL2	{0}	{1o}	{1oc}	{2oc}
3308	✓	✓	✓	✓

Diesel engine: Preglow time [t_{PH}] **0 to 999 s**

Prior to each start, the diesel engine is preheated for this time (if a "0" has been configured here the engine will be started without preglow). The display indicates "Preglow".

EN	Preglow mode			
DE	Vorglühmodus			
CL2	{0}	{1o}	{1oc}	{2oc}
3347	✓	✓	✓	✓

Diesel engine: Preglow mode **Off / Always / Analog**

This parameter dictates if and under what conditions a diesel engine is preheated.
Off..... The diesel engine is never preheated before a start attempt.
Always Before a start attempt the "Preheating" relay is always energized for the preglow time (parameter 3308). After that a start attempt is initiated.
Analog A preglow sequence is initiated if the monitored analog input temperature (coolant temperature) is below the configured threshold (parameter 3309). The preglow sequence is enabled for the configured preglow time (parameter 3308). After that a start attempt is initiated.

EN	Preglow criterion			
DE	Vorglühlen Kriterium			
CL2	{0}	{1o}	{1oc}	{2oc}
3346	✓	✓	✓	✓

Diesel engine: Preglow criterion **refer to text below**

The preglow criterion may be selected from the available data sources. Use the **1** and **2** softkeys to scroll through the list of variables and confirm your selection with the **3** softkey. Refer to Appendix C on page 307 for a list of all data sources. Usually, a temperature measuring is selected here, which is measured via a sensor.

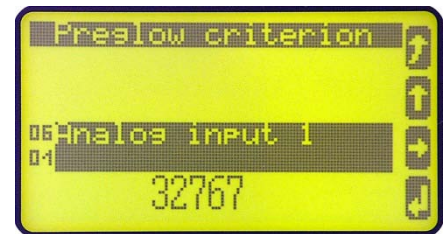

Figure 3-19: Configure application - engine - preglow criterion selection

EN	Preglow temperature threshold			
DE	Vorglühlen wenn Temperatur			
CL2	{0}	{1o}	{1oc}	{2oc}
3309	✓	✓	✓	✓

Diesel engine: Preglow temperature threshold **-10 to 250 °C**

This is the temperature threshold, which must be exceeded to prevent a preheating process, if parameter 3347 has been configured to "Analog".

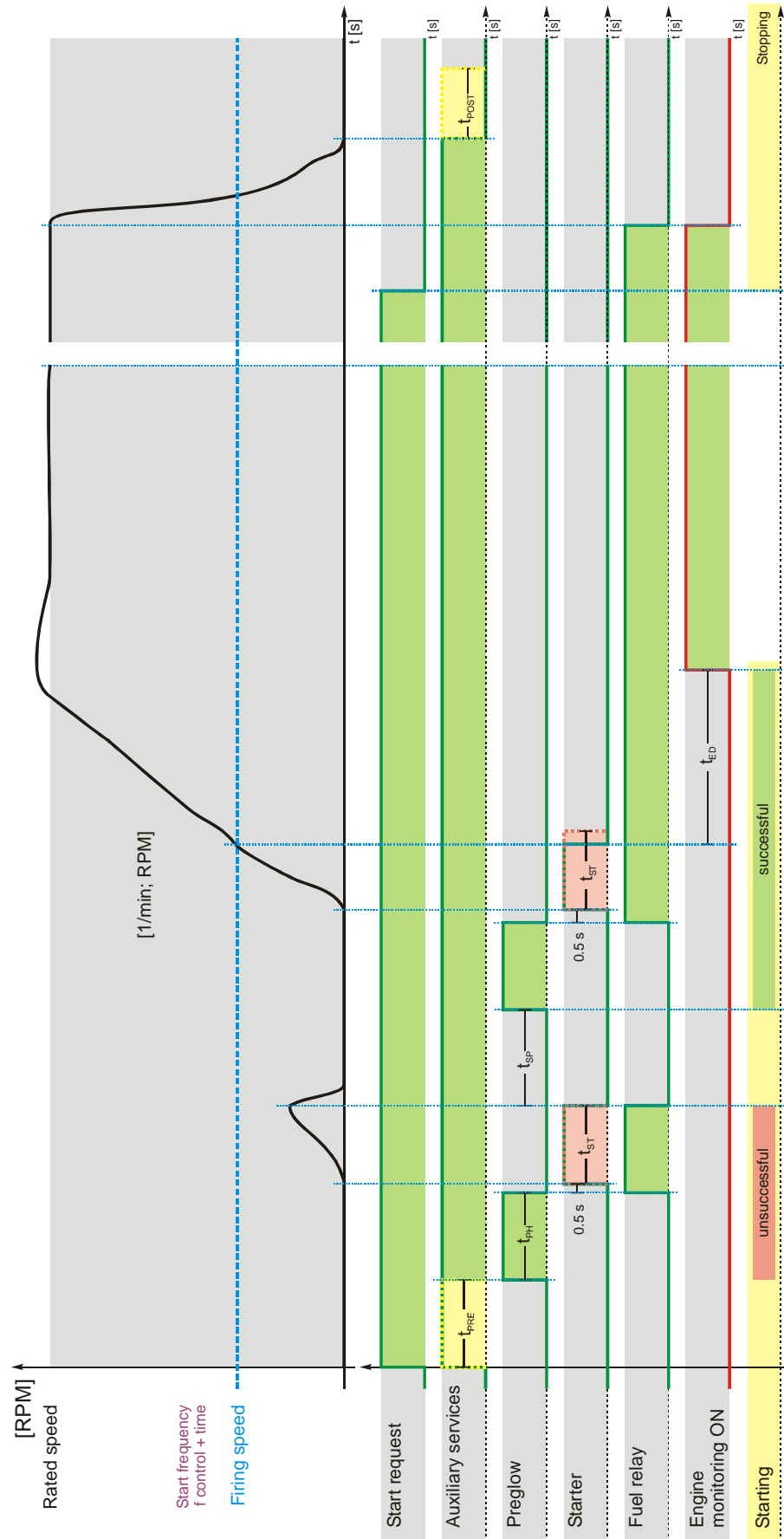

Figure 3-20: Start /stop sequence - diesel engine

Engine: Gas Engine

Start sequence

Function: The starter is engaged ("**Turning**" is displayed). Following the expiration of the firing delay time and if the engine is rotating with at least the configured "minimum speed for ignition", the ignition is switched on ("**Ignition**" is displayed). Following the expiration of the gas valve delay, the gas valve is then enabled ("**Start**" is displayed). If the configured firing speed is exceeded, the starter is disengaged. The gas valve and the ignition remain enabled via the firing speed. "**Ramp to rated**" is displayed until the engine monitoring delay timer expires and the start sequence has finished.

If the configured "minimum speed for ignition" is not reached, a start pause is initiated ("**Start - Pause**" is displayed) before the next start attempt.

Stop sequence

Function: After opening the GCB, the coasting time starts and the engine runs without load ("**Cool down**" is displayed). On termination of the coasting time, the gas valve is closed or de-energized, and the engine is stopped ("**Stop engine**" is displayed). If the engine cannot be stopped, the alarm message "**Eng. stop malfunct.**" is displayed. If no speed is detected anymore, the ignition remains active for 5 seconds so that the remaining gas is able to combust.



CAUTION

It is imperative to connect an emergency stop circuit to discrete input DI 1 to be able to perform an emergency stop by disabling the ignition in case the gas valve fails to close.

Start/stop diagram

The formula signs and indices mean:

- t_{PRE}..... Auxiliary services prerun [s] (parameter 3300 on page 188)
- t_{ST} Starter time [s] (parameter 3306 on page 184)
- t_{SP}..... Start pause..... [s] (parameter 3307 on page 184)
- t_{ID}..... Ignition delay [s] (parameter 3310 on page 181)
- t_{GD}..... Gas delay [s] (parameter 3311 on page 181)
- t_{ED}..... Engine delayed monitoring..... [s] (parameter 3315 on page 186)
- t_{POST}..... Auxiliary services postrun [s] (parameter 3301 on page 188)
- t_{CD}..... Cool down time [s] (parameter 3316 on page 187)
- t_{IC}..... Ignition coasting ("post burning") . [s] (fixed to 5 seconds)
- t_{GS}..... Generator stable time [s] (parameter 3415 on page 153)

EN	Ignition delay					Gas engine: Ignition delay [t_{ID}]	1 to 999 s
DE	Zündverzögerung						
CL2	{0}	{1o}	{1oc}	{2oc}			
3310	✓	✓	✓	✓			

With gas engines often a purging operation is desired before starting. With the engaging of the starter the ignition delay is started. The display indicates "**Turning**". If the "Minimum speed for ignition" is reached after the expiration of this time, the ignition is energized.

EN	Gas valve delay					Gas engine: Gas valve delay [t_{GD}]	0 to 999 s
DE	Gasverzögerung						
CL2	{0}	{1o}	{1oc}	{2oc}			
3311	✓	✓	✓	✓			

By energizing the ignition relay the gas valve delay is started ("**Ignition**" is displayed). After the time set here has expired, and as long as the speed is higher than the minimum speed for ignition, the gas valve is enabled for the time configured in parameter 3306 "Starter time" ("**Start**" is displayed). Once the ignition speed has been reached, the gas valve remains opened. If the speed falls below ignition speed, the gas valve will be closed and the "Ignition" relay is de-energized 5 seconds later.

EN	Minimum speed for ignition					Gas engine: Minimum speed for ignition	10 to 1.800 RPM
DE	Mindestdrehz. für Zündung						
CL2	{0}	{1o}	{1oc}	{2oc}			
3312	✓	✓	✓	✓			

After expiration of the ignition delay the number of revolutions set here must be reached, so the "Ignition" relay will be energized.

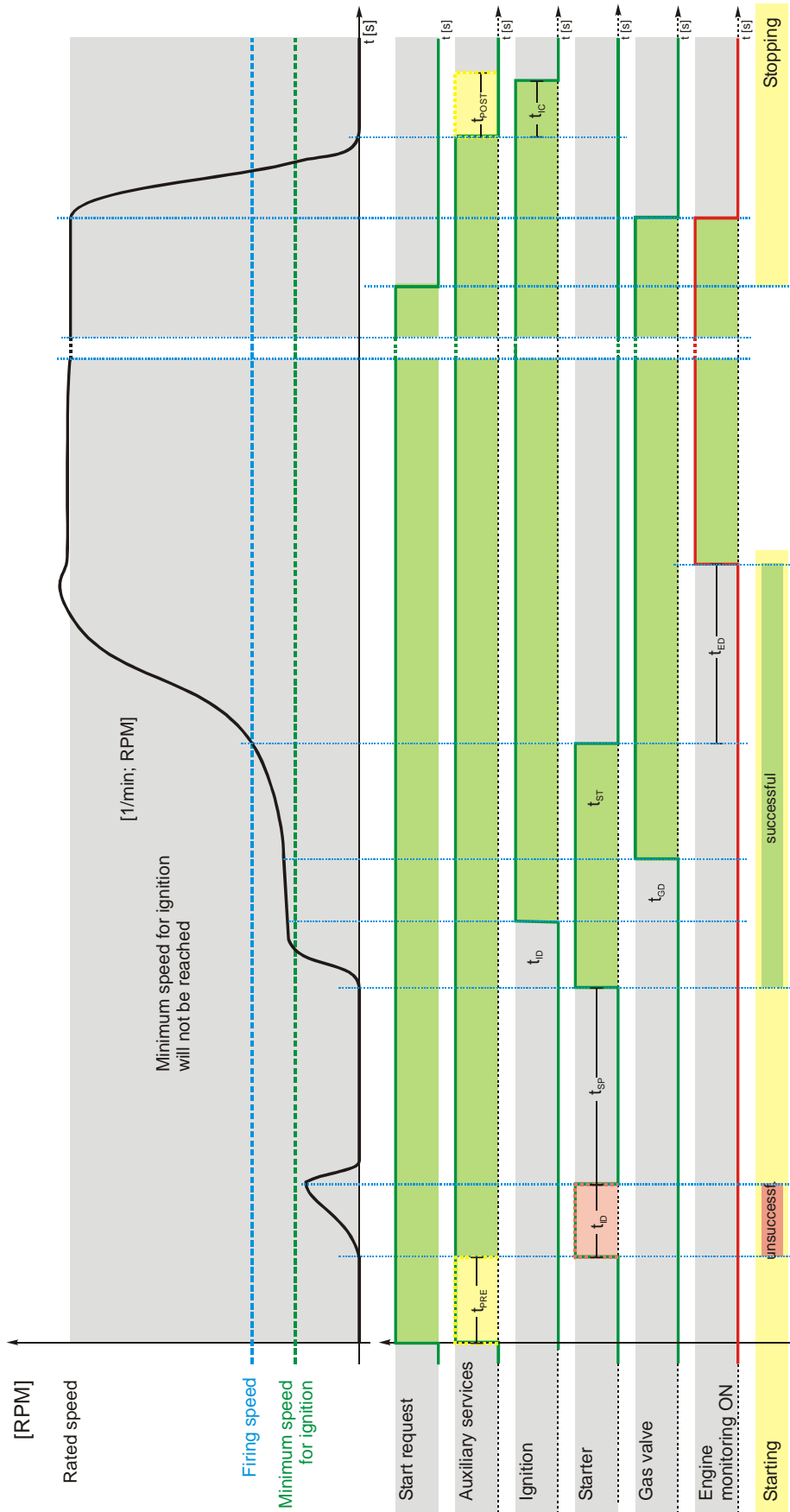

Figure 3-21: Start /stop sequence - gas engine - successful

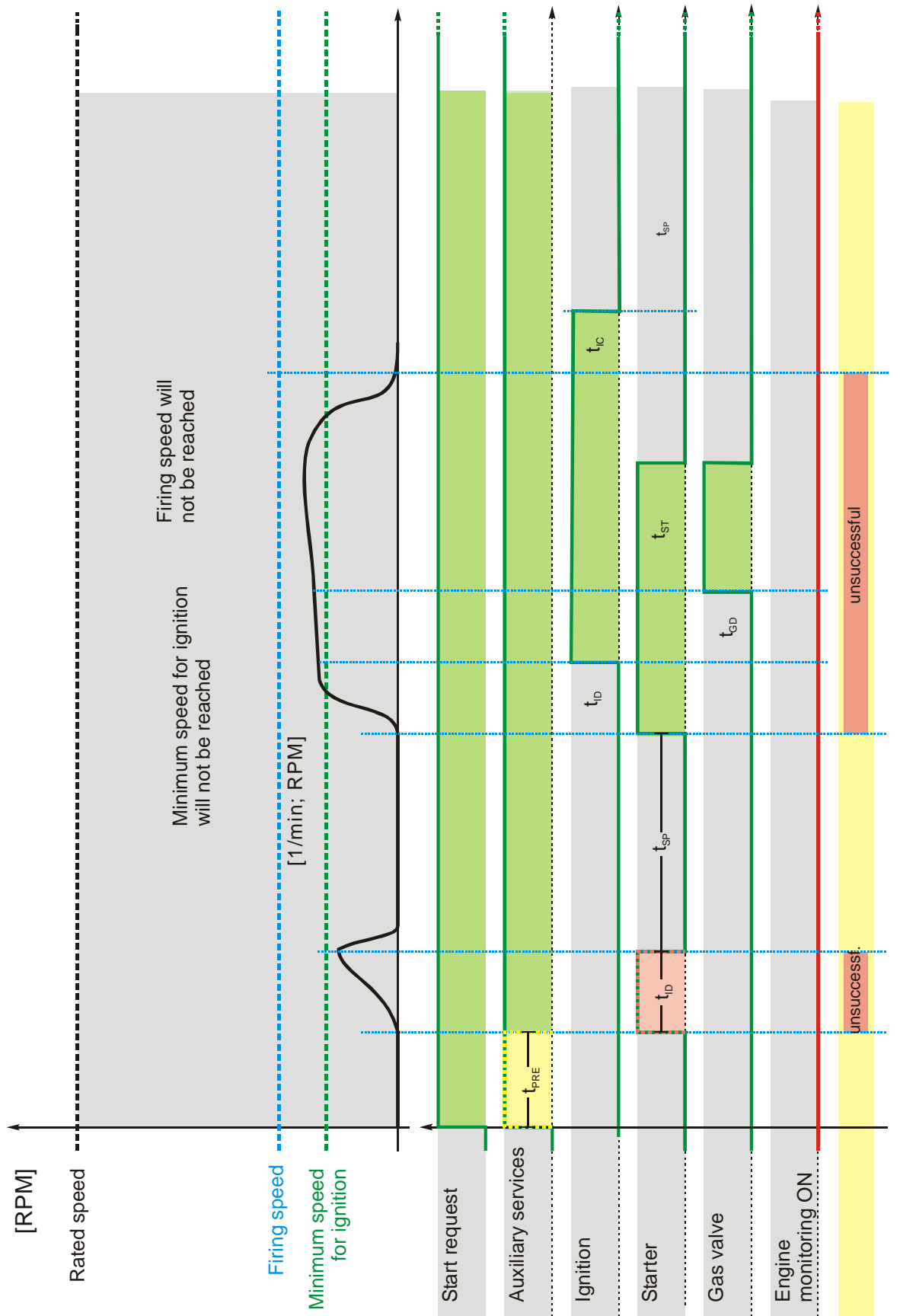

Figure 3-22: Start /stop sequence - gas engine - unsuccessful

Configure Application: Configure Engine, Start/Stop

Parameter table

Level	Text	Setting range	Default value
Configure start/stop			
	Start attempts	1 to 20	3
	Start attempts critical mode	1 to 20	10
	Starter time	1 to 99 s	5 s
	Start pause time	1 to 99 s	7 s
	Stop time of engine	1 to 99 s	10 s
	Firing speed	5 to 60 Hz	15 Hz
	LogicsManager for firing speed	Yes / No	No
	Firing speed	<i>LogicsManager</i>	(0 & 1) & 1
	Engine monitoring delay time	1 to 99 s	8 s
	Cool down time	1 to 9999 s	180 s
	Cool down in STOP mode	Yes / No	Yes
	Cool down without breaker	Yes / No	No
	Auxiliary services prerun	0 to 9999 s	0 s
	Auxiliary services postrun	0 to 9999 s	0 s

Table 3-87: Application - standard values - configure start/stop

EN	Start attempts
DE	Anzahl Startversuche
CL2	{0} {10} {10c} {20c}
3302	✓ ✓ ✓ ✓

Start alarm: Number of starting attempts **1 to 20**

The control will attempt to start the engine with this number of start attempts. If the engine fails to start after the configured number of attempts, an alarm will be initiated. An engine has been successfully started if the ignition speed reaches the configured firing speed and the delayed engine monitoring has expired.

EN	Start attempts critical mode
DE	Anzahl Startversuche Sprinkler
CL2	{0} {10} {10c} {20c}
4102	✓ ✓ ✓ ✓

Start alarm: Number of starting attempts in critical mode **1 to 20**

If a critical operation mode (refer to Configure Application: Automatic, Critical Mode (Sprinkler Operation, *LogicsManager*) on page 212) is initiated, the engine will continue to attempt to start for the number of starts configured here. An engine has been successfully started if the ignition speed reaches the configured firing speed and the delayed engine monitoring has expired.

EN	Starter time
DE	Einrückzeit Anlasser
CL2	{0} {10} {10c} {20c}
3306	✓ ✓ ✓ ✓

Engine: Maximum starter delay [t_{ST}] **1 to 99 s**

This is the maximum time that the starter relay will remain energized ("Start" display). If the *LogicsManager* output "Ignition speed reached" = TRUE, the speed/frequency have reached firing speed, or the time has expired, the relay will be de-energized.

EN	Start pause time
DE	Startpausenzeit
CL2	{0} {10} {10c} {20c}
3307	✓ ✓ ✓ ✓

Engine: Start pause time [t_{SP}] **1 to 99 s**

This is the delay time between the individual starting attempts. This time is also used to protect the starter relay. The message "Start - Pause" is displayed.

EN	Stop time of engine
DE	Zeit für Motorstop
CL2	{0} {10} {10c} {20c}
3326	✓ ✓ ✓ ✓

Engine: Engine blocking **0 to 99 s**

During this time a restart of the engine is blocked. This time should be configured so that the engine is total shutdown to protect the starting circuit. Once speed from the engine is no longer detected the time configured in this parameter is initiated. The message "Stop engine" is displayed. The *LogicsManager* command variable "Stop solenoid" (03.27) becomes TRUE as soon as the stop signal has been issued and remains true until this timer has expired.

Engine: Firing Speed And Engine Delayed Monitoring

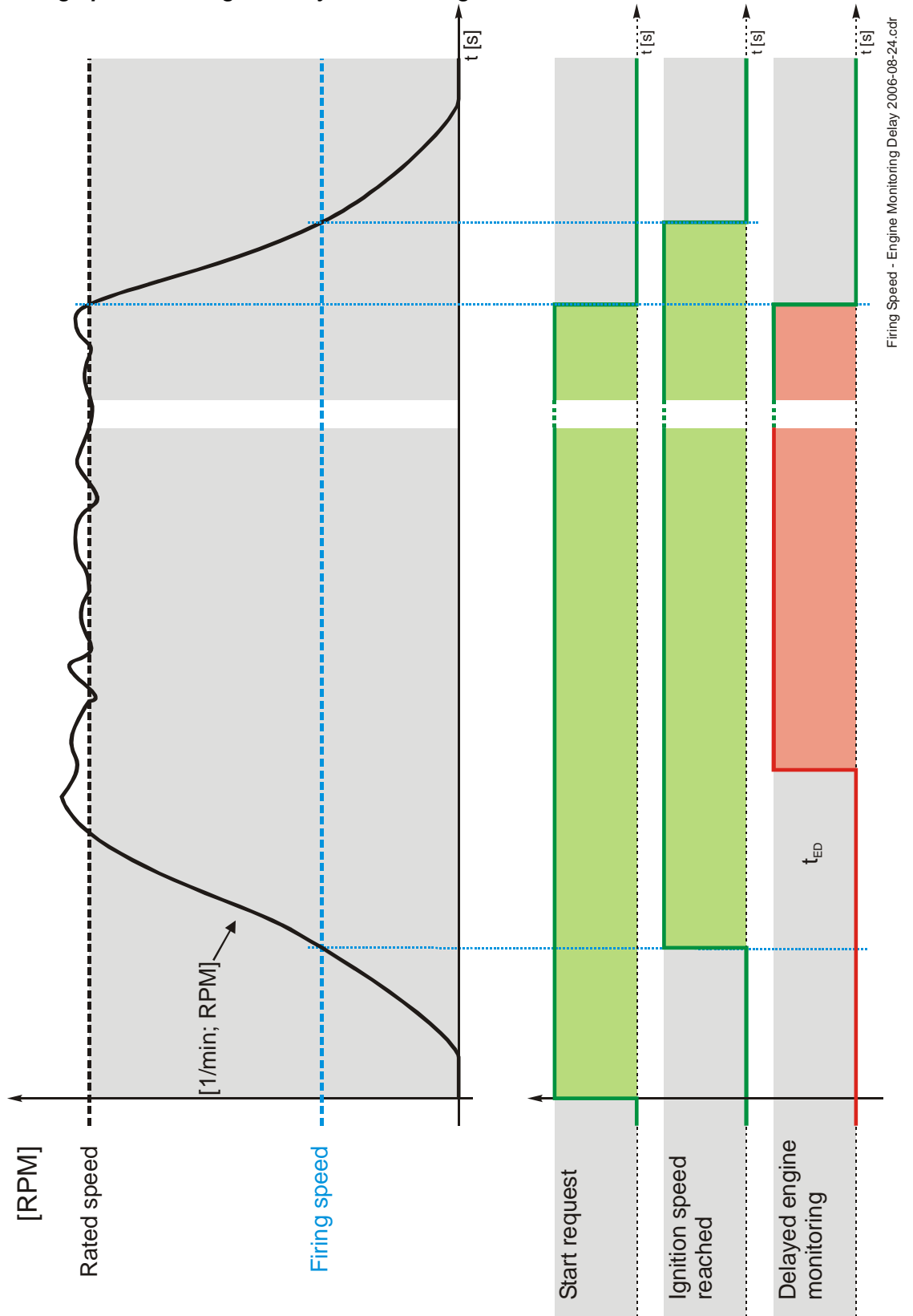

Firing Speed - Engine Monitoring Delay 2006-08-24.cdr

Figure 3-23: Engine - firing speed and engine delayed monitoring



NOTE

When the ignition speed is reached, the starter is disengaged under one of the following conditions:

- The measurement via **MPU is enabled** (On):
 - ⇒ Ignition speed is detected
 - ⇒ Ignition speed (measured via the generator voltage) is detected
 - ⇒ Conditions for "Ignition speed" (see *LogicsManager*) equal true.
- The measurement via **MPU is disabled** (Off):
 - ⇒ Ignition speed (measured via the generator voltage) is detected
 - ⇒ Conditions for "Ignition speed" (see *LogicsManager*) equal true.

Pickup	Generator frequency	Engine speed	<i>LogicsManager</i>
Off	Yes	No	Yes (if programmed)
On	Yes	Yes	Yes (if programmed)

EN	Firing speed				Engine: Firing speed	5 to 60 Hz
DE	Zünddrehzahl					
CL2 3313	{0} ✓	{1o} ✓	{1oc} ✓	{2oc} ✓	After firing speed has been reached, the starter is disengaged and the time counter for the engine delayed monitoring is activated. The firing speed is to be configured low enough that it is always exceeded during regular generator operation.	

Note: Frequency measurement via the generator voltage input is possible beginning with 15 Hz or higher. If the MPU measurement is enabled, values down to 5 Hz can be measured.

EN	LogicsManager for firing speed				Engine: Firing speed via <i>LogicsManager</i>	Yes / No
DE	Logikm. für Zünddrehzahl					
CL2 3324	{0} ✓	{1o} ✓	{1oc} ✓	{2oc} ✓	Yes The engine firing speed is additionally monitored by the <i>LogicsManager</i> .	
					No The firing speed is measured by the speed/frequency input (MPU), not via the <i>LogicsManager</i> .	

EN	Firing speed				Engine: Firing speed reached via <i>LogicsManager</i>	<i>LogicsManager</i>
DE	Zünddrehzahl					
CL2 12500	{0} ✓	{1o} ✓	{1oc} ✓	{2oc} ✓	This screen is only visible if parameter 3324 is configured to Yes. Once the conditions of the <i>LogicsManager</i> have been fulfilled the ignition speed will be recognized as above minimum limit (e.g. via an oil pressure switch). The <i>LogicsManager</i> and its default settings are explained on page 273 in Appendix B: " <i>LogicsManager</i> ".	

After reaching the firing speed, the engine delayed monitoring timer is started. Upon expiration of this timer all "engine delayed monitoring" configured alarms and discrete inputs will be enabled.

EN	Engine monitoring delay time				Engine: Engine delayed monitoring [t _{ED}]	0 to 99 s
DE	Verzög. Motorüberwach.					
CL2 3315	{0} ✓	{1o} ✓	{1oc} ✓	{2oc} ✓	Delay between reaching the firing speed and activation of the monitoring of engine speed delayed alarms (i.e. underspeed).	

This timer should be configured in such a manner that it corresponds to the starting time of the engine plus any possible startup transients. A GCB closure may take place after the expiration of this timer. Note: The GCB closure can be initiated prior to engine delayed monitoring by configuring the *LogicsManager* "Undelay close GCB" (parameter 12210 on page 153).

Engine: Cool Down

EN	Cool down time				Engine: Cool down time [t _{CD}]	1 to 999 s
DE	Motor Nachlaufzeit					
CL2 3316	{0}	{10}	{10c}	{20c}		
	✓	✓	✓	✓		

Regular stop: If the engine performs a normal stop (start request is disabled or change into STOP operating mode) or a stop caused by an alarm of alarm class C/D, a cool down with an opened GCB is carried out. This time is programmable. The message "Cool down" is displayed and the *LogicsManager* command variable 04.10 becomes TRUE.

Stop by a class 'C' or 'D' alarm: If the engine is stopped by an alarm of this alarm class, a cool down is carried out with an opened GCB. This time is programmable.

Stop by a class 'E' or 'F' alarm: If the engine is stopped by an alarm of this alarm class, the engine is shutdown without a cool down immediately.



NOTE

If a critical operation mode (refer to Configure Application: Automatic, Critical Mode (Sprinkler Operation, *LogicsManager*) on page 212) is initiated, the time configured in critical mode postrun (parameter 4109) will be used instead of the cool down time.

EN	Cool down in STOP mode				Engine: Cool down time in STOP mode	Yes / No
DE	Nachlauf Betriebsart STOP					
CL2 3319	{0}	{10}	{10c}	{20c}		
	✓	✓	✓	✓		

Yes A cool down will be performed if the genset is changed to STOP operation mode.

No..... No cool down will be performed if the genset is changed to STOP operation mode.

EN	Cool down without breaker				Engine: Cool down without breaker	Yes / No
DE	Nachlauf ohne LS					
CL2 3322	{0}	{10}	{10c}	{20c}		
	✓	✓	---	---		

This parameter may be used to perform a cool down if the application mode (parameter 3401 on page 141) is configured to "None" or "GCB open".

Yes A cool down will be performed if a start signal is disabled or a stop signal is enabled.

No..... No cool down will be performed if a start signal is disabled or a stop signal is enabled.

Engine: Auxiliary Operations

The auxiliary operations start, as soon as the engine is to be started or a running engine is detected. At the same time, the discrete output for the auxiliary services (*LogicsManager* 03.01) will be enabled. This discrete output remains enabled as long as speed is detected or if the controller is in the MANUAL mode.

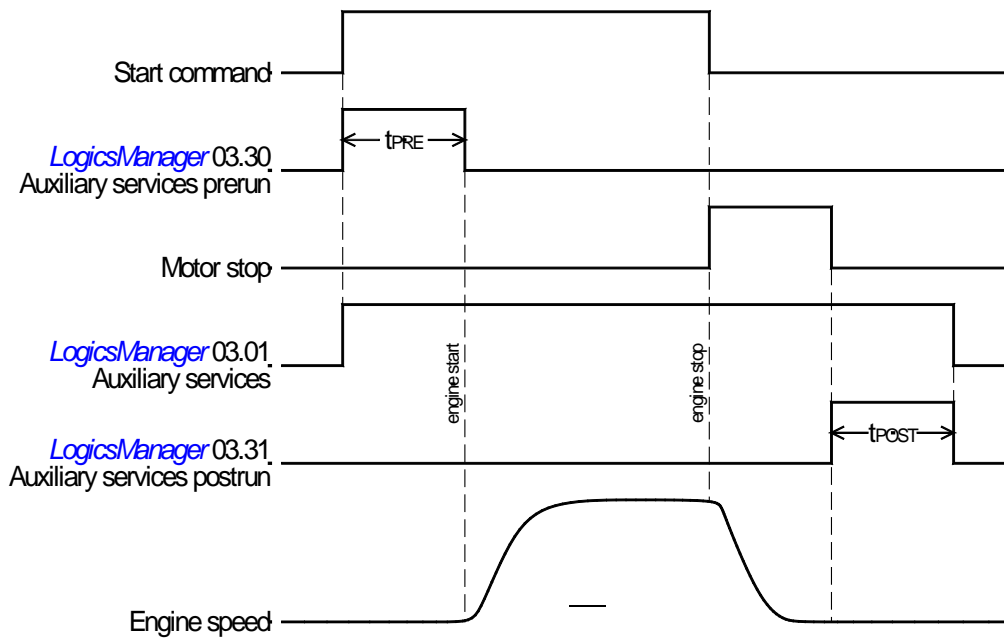

Figure 3-24: Engine - Auxiliary services timing

EN	Auxiliary services prerun			
DE	Hilfsbetriebe Vorlauf			
CL2	{0}	{1o}	{1oc}	{2oc}
3300	✓	✓	✓	✓

Engine: Prerun auxiliary operation (start preparation) [t_{PRE}] **0 to 999 s**

! CAUTION:
During an emergency start this delay time "auxiliary prerun" is not initialized. The engine will be started immediately.

Prior to a start sequence being initiated, the discrete output for the auxiliary services prerun (*LogicsManager* 03.30) remains enabled for the configured amount of time to permit engine related operations (i.e. open louvers) to be performed. While this discrete output is enabled the control screen will display the message "**Aux.serv.prerun**" for the configured time.

The auxiliary services discrete output disables when the operation mode is changed from the MANUAL operation mode or, if engine speed is no longer detected, when the discrete output for the auxiliary services postrun (*LogicsManager* 03.31) is disabled.

EN	Auxiliary services postrun			
DE	Hilfsbetriebe Nachlauf			
CL2	{0}	{1o}	{1oc}	{2oc}
3301	✓	✓	✓	✓

Engine: Coasting auxiliary operation (post operation) [t_{POST}] **0 to 999 s**

After each engine stop (the engine stop timer has expired), the discrete output for the auxiliary services postrun (*LogicsManager* 03.31) remains energized for an adjustable time (i.e. operate a cooling pump). If the operating mode is changed from MANUAL to STOP or AUTOMATIC without a start command the relay remains energized for this period of time. The message "**Aux.serv.postrun**" will be displayed on the control unit screen. In the "MANUAL" operating mode this relay output is not used.

Configure Application: Configure Engine, MPU

Parameter table

Level	Text	Setting range	Default value
Configure MPU			
	MPU input	On / Off	On
	Fly wheel teeth	2 to 260	118

Table 3-88: Application - standard values - configure MPU

To configure the MPU input, the Number of teeth on the flywheel detected by the magnetic pick up (MPU) or the number of pickup pulses per revolution of the engine must be configured:

EN	MPU input	Pickup	On / Off
DE	Pickup		
CL2	{0} {10} {10c} {20c}	On	Speed monitoring of the engine is carried out by the MPU.
1600	✓ ✓ ✓ ✓	Off	Speed/frequency monitoring of the generator set (the engine) is performed by measuring the frequency of the generator. There is no MPU wired to this unit.
EN	Fly wheel teeth	Number of flywheel teeth	2 to 260
DE	Anzahl Pickup-Zähne		
CL2	{0} {10} {10c} {20c}	Number of pulse per revolution/teeth on the flywheel.	
1602	✓ ✓ ✓ ✓		

Table 3-89 shows the speed measuring range for various flywheel teeth numbers (parameter 1602) and rated speeds (parameter 1601 on page 39) for a minimum signal voltage of 2 V.

Fly wheel teeth	Rated speed [rpm]	Minimum voltage [V]	Speed measuring range [rpm]
5	1500	2	700 to 10000
5	1800	2	700 to 10000
5	3000	2	700 to 10000
5	3600	2	700 to 10000
10	750	2	350 to 10000
10	1500	2	350 to 10000
10	1800	2	350 to 10000
10	3000	2	350 to 10000
10	3600	2	350 to 10000
25	750	2	135 to 10000
25	1500	2	135 to 10000
25	1800	2	135 to 10000
25	3000	2	135 to 10000
25	3600	2	135 to 10000
50	750	2	65 to 10000
50	1500	2	65 to 10000
50	1800	2	65 to 10000
50	3000	2	65 to 10000
50	3600	2	65 to 10000
100	750	2	35 to 5000
100	1500	2	35 to 5000
100	1800	2	35 to 5000
100	3000	2	50 to 5000
100	3600	2	50 to 5000
150	750	2	25 to 5000
150	1500	2	35 to 5000
150	1800	2	35 to 5000
150	3000	2	35 to 5000
150	3600	2	35 to 5000
200	750	2	20 to 3850
200	1500	2	25 to 3850
200	1800	2	25 to 3850
200	3000	2	25 to 3850
200	3600	2	25 to 3850
260	750	2	15 to 2885
260	1500	2	22 to 2885
260	1800	2	22 to 2885

Table 3-89: MPU input - typical configurations

Configure Application: Configure Engine, Idle Mode

When the engine is operated at idle speed, undervoltage, underfrequency, and underspeed monitoring as well as the monitoring of the flexible limits 13 through 16 are not performed. This function allows for a controlled operation of an engine without alarm messages at a lower speed (below the configured underspeed monitoring values) for e.g. a warm-up operation with low emission. The frequency controller output does not control the idle speed; it will remain in initial state position. The GCB cannot be closed in idle mode. A message may be output to a relay here using the *LogicsManager* (Idle mode is active, command variable 04.15), e.g. as a signal for a speed controller. The display indicates "Idle run active" during idle mode.

Parameter table

Level	Text	Setting range	Default value
Configure idle mode			
	Auto idle mode	<i>LogicsManager</i>	(0 & 1) ≥ 0
	Constant idle run	<i>LogicsManager</i>	(0 & 1) & 1
	Automatic idle time	1 to 9999 s	30 s
	During emergency / critical	Yes / No	No

Table 3-90: Application - standard values - configure idle mode

EN	Auto idle mode			
DE	Automatic Idle Modus			
CL2	{0}	{1o}	{1oc}	{2oc}
12570	✓	✓	✓	✓

Engine: *LogicsManager* automatic idle mode *LogicsManager*

Once the conditions of the *LogicsManager* have been fulfilled the engine will be operated in idle mode automatically for the configured time during start-up. Monitoring is limited as described above. This function may always be configured to "1" for example. The *LogicsManager* and its default settings are explained on page 273 in Appendix B: "*LogicsManager*".

EN	Constant idle run			
DE	Dauernd Idle Modus			
CL2	{0}	{1o}	{1oc}	{2oc}
12550	✓	✓	✓	✓

Engine: *LogicsManager* continuous idle mode *LogicsManager*

As long as the conditions of the *LogicsManager* have been fulfilled the engine will be continuously operated in idle mode. Monitoring is limited as described above. A key switch via a DI may be configured here for example. The *LogicsManager* and its default settings are explained on page 273 in Appendix B: "*LogicsManager*".

Note: The idle mode is blocked if the GCB is already closed.

EN	Automatic idle time			
DE	Zeit für Automatic Idle Modus			
CL2	{0}	{1o}	{1oc}	{2oc}
3328	✓	✓	✓	✓

Engine: Time for automatic idle mode 1 to 9999 s

The automatic idle mode is active for the time configured here. Monitoring is limited as described above during this time.

EN	During emergency / critical			
DE	Während Notstrom/Sprinkler			
CL2	{0}	{1o}	{1oc}	{2oc}
3329	✓	✓	✓	✓

Engine: Idle mode possible during emergency / critical operation Yes / No

Yes If an emergency or critical operation is enabled, the engine will go to rated speed only after completing the configured idle mode.
No If an emergency or critical operation is enabled, no idle run will be performed the engine will go directly to rated speed.



NOTE

The normal operation monitoring limits will be enabled again, if one of the following conditions is fulfilled:

- Idle mode has ended and generator frequency and voltage are within the operating range of the generator (refer to
- Configure Monitoring: Generator, Operating Voltage / Frequency on page 50).
- Idle mode has ended and engine delayed monitoring (parameter 3315 on page 186) has expired.



NOTE

The flexible limits 13 through 16 are disabled during idle mode operation (refer to Configure Monitoring: Flexible Limits on page 121).

Configure Application: Configure Emergency Run



NOTE

The emergency power operation is possible only in application mode {2oc} (2 power circuit breakers). If the *LogicsManager* outputs 'Stop request in AUTO' or 'Inhibit emergency run' are TRUE, an emergency power operation may be prevented or interrupted from an external source.

Prerequisite: The emergency power function can only be activated for synchronous generators with parameter 2802. Emergency power is carried out in operating mode AUTOMATIC regardless of the status of the *LogicsManager* output 'Start request in AUTO' (*LogicsManager*).

The display indicates "**Emergency run**" during emergency power operation.

The following principles are observed in case of an emergency power operation:

- If an emergency power operation is initiated, the engine is started automatically, unless the start sequence is interrupted via an alarm or prevented via the *LogicsManager* or the operating mode is changed.
- The GCB can be closed regardless of the engine delay time if the generator frequency and voltage are within the configured operating limits (refer to Configure Monitoring: Generator, Operating Voltage / Frequency on page 50) if the parameter "Undelay close GCB" (parameter 12210 on page 153) has been set accordingly (default setting).
- If the mains return during an emergency power operation (GCB is closed), the mains settling time (parameter 2801 on page 85) must expire before the load is transferred from the generator to mains operation.

Activation of emergency power: If the mains are not within the configured frequency and voltage operating limits (refer to Configure Monitoring: Mains, Operating Voltage / Frequency on page 85) for at least the time configured in the parameter "Mains fail delay time" (parameter 2800), an emergency power operation is activated.

MCB malfunction: An emergency power operation will be performed, if the control is not able to close or reclose the MCB and the alarm "Fail to close MCB" occurs.

Mains rotation field alarm: If the mains returns after a mains failure with a reversed rotation direction the generator remains in emergency power operation until the mains rotation matches the rotation of the generator set.



NOTE

The generator will not start upon a mains rotation field alarm, but it will keep on running if it has already started.

Parameter table

Level	Text	Setting range	Default value
Configure emergency run			
	On / Off	On / Off	On
	Mains fail delay time	0.00 to 99.99 s	3.00 s
	Emerg. start with MCB failure	Yes / No	Yes
	Inhibit emerg. run	<i>LogicsManager</i>	(0 & 1) & 1
	Break emerg. In critical mode	0 to 999 s	5 s

Table 3-91: Application - standard values - configure emergency run

EN	On / Off
DE	Ein/Aus
CL2	{0} {1o} {1oc} {2oc}
2802	--- --- --- ✓

Emergency power: Monitoring

On / Off

On If the unit is in the AUTOMATIC operating mode and a mains fault occurs according to the following parameters, the engine is started and an automatic emergency operation is carried out.

Off..... No emergency operation is carried out.

EN	Mains fail delay time
DE	Startverzögerung
CL2	{0} {1o} {1oc} {2oc}
2800	--- --- --- ✓

Emergency power: Mains failure: Start delay

0.00 to 99.99 s

To start the engine and to carry out an emergency operation the monitored mains must be failed continuously for the minimum period of time set with this parameter. This delay time starts only if the easYgen is in AUTOMATIC operating mode and emergency power is activated.

EN	Emerg. start with MCB failure
DE	Bei NLS-Fehler aktivieren
CL2	{0} {1o} {1oc} {2oc}
3408	--- --- --- ✓

Emergency power: Emergency operation by MCB failure

Yes / No

Emergency power operations may be configured with the failure of the MCB in addition to a loss of power on the mains supply. An MCB breaker alarm is indicated if parameter "MCB monitoring" (parameter 2620 on page 119) is configured "On".

EN	Inhibit emerg. run
DE	Kein Notstrombetrieb
CL2	{0} {1o} {1oc} {2oc}
12200	--- --- --- ✓

Emergency power: Inhibit emergency power

LogicsManager

Once the conditions of the *LogicsManager* have been fulfilled the emergency power operation will be terminated or blocked. The *LogicsManager* and its default settings are explained on page 273 in Appendix B: "*LogicsManager*".

EN	Break emerg. in critical mode
DE	Pause Notstrom bei Sprinkler
CL2	{0} {1o} {1oc} {2oc}
4101	--- --- --- ✓

Emergency power: Override emergency operations in critical mode

0 to 999 s

The emergency power operations are overridden for the configured time when the critical mode starts in order to supply the complete generator power to the sprinkler pump.

Configure Application: Configure Automatic Run

Configure Application: Automatic, Start In AUTOMATIC Operating Mode (*LogicsManager*)

The start of the engine can be performed via different logical conditions. This can be:

- a discrete input
- a temperature level
- an interface start condition
- a start request from the LDSS function
- a timer
- any logical combination

If this logical output becomes TRUE in AUTOMATIC operating mode, the generator starts and the GCB will be closed. The simultaneous activation of other *LogicsManager* outputs (e.g. Stop req. in Auto) may affect this function.

The breaker handling depends on the configured application mode and breaker logic.



NOTE

Refer to Figure 3-25 and Priority Hierarchy of the Logical Outputs on page 277 for the priority of the logical outputs in case that more than one logical output is TRUE.

Parameter table

Level	Text	Setting range	Default value
Configure automatic run			
	Start req in AUTO	<i>LogicsManager</i>	(09.02 ≥ 0) ≥ 0
	Stop req. in AUTO	<i>LogicsManager</i>	(0 & 1) & 1
	Start w/o load	<i>LogicsManager</i>	(0 & 1) & 1
	Startup in mode	STOP / AUTO / MAN / Last	STOP
	Operat. mode AUTO	<i>LogicsManager</i>	(0 & 1) & 1
	Operat. mode MAN	<i>LogicsManager</i>	(0 & 1) & 1
	Operat. mode STOP	<i>LogicsManager</i>	(0 & 1) & 1

Table 3-92: Application - standard values - configure automatic run

EN	Start req in Auto				
DE	Startanf. in Auto				
CL2	{0}	{1o}	{1oc}	{2oc}	
12120	✓	✓	✓	✓	

Start request in operation mode AUTOMATIC

LogicsManager

Once the conditions of the *LogicsManager* have been fulfilled, the control issues a start request in AUTOMATIC mode. The *LogicsManager* and its default settings are explained on page 273 in Appendix B: "*LogicsManager*".

Configure Application: Automatic, Stop In AUTOMATIC Operating Mode (*LogicsManager*)

If this logical output becomes TRUE, it inhibits all other start processes (e.g. Start req. in Auto, emergency power, etc.). Stopping of the engine can be initiated externally via a discrete input or any logical combination.

EN	Stop req. in Auto				Stop request in operation mode AUTOMATIC	<i>LogicsManager</i>
DE	Stopanf. in Auto					
CL2	{0}	{1o}	{1oc}	{2oc}	Once the conditions of the <i>LogicsManager</i> have been fulfilled, the control issues a stop request in AUTOMATIC mode. The <i>LogicsManager</i> and its default settings are explained on page 273 in Appendix B: " <i>LogicsManager</i> ".	
12190	✓	✓	✓	✓		

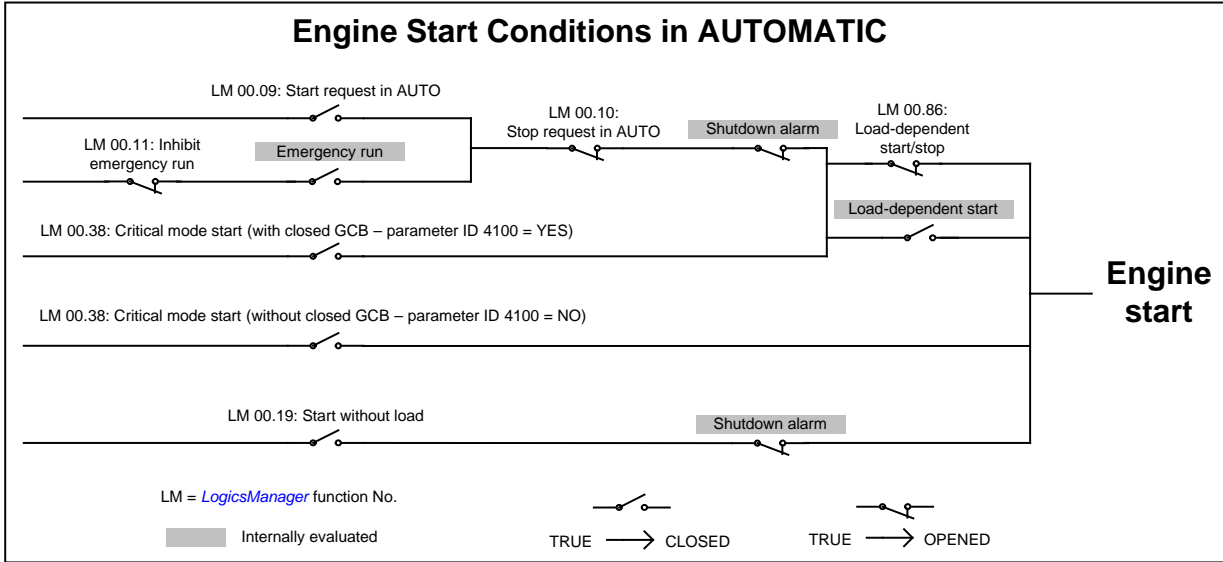

Figure 3-25: Automatic run - engine start conditions

Configure Application: Automatic, Load-Dependent Start/Stop (LDSS)

Refer to Appendix G: LDSS Formulas on page 334 for all formulas related with the LDSS function.

Load-dependent start/stop may either be performed according to a system reserve power or the generator load depending on the configuration of the "Start stop mode" (parameter 5752 on page 198).

Configure Application: Automatic, Load-Dependent Start/Stop: System Reserve Power

If the "Start stop mode" (parameter 5752 on page 198) is configured to "Reserve power", load-dependent start stop is performed in a way that a configured minimum reserve power is maintained in the system. This means that there is always enough reserve power for load swings on the busbar regardless of the generator load. The actual reserve power in the system is the total rated power of all gensets on the busbar minus the actual total generator real power.

This functionality provides high system reliability and is intended for applications that require a dedicated reserve power on the busbar, independent of the number of gensets on the busbar.

The following parameters need to be configured for this operation:

Parameter ID	Parameter text	Note
5760	IOP Reserve power	only for isolated operation
5761	IOP Hysteresis	only for isolated operation
5767	MOP Minimum load	only for mains parallel operation
5768	MOP Reserve power	only for mains parallel operation
5769	MOP Hysteresis	only for mains parallel operation

Table 3-93: Load-dependent start/stop - parameters for reserve power operation

Isolated Operation

$$P_{\text{Reserve}} = P_{\text{rated active}} - P_{\text{GN real active}}$$

$$P_{\text{rated active}} = P_{\text{RatedGen}[1]} + P_{\text{RatedGen}[2]} + \dots + P_{\text{RatedGen}[n]} \text{ (total rated power of all gensets on the busbar in the system)}$$

$$P_{\text{GN real active}} = P_{\text{ActualGen}[1]} + P_{\text{ActualGen}[2]} + \dots + P_{\text{ActualGen}[n]} \text{ (total actual load of all gensets on the busbar in the system)}$$

If the reserve power falls below the IOP reserve power threshold (parameter 5760), another genset will be added.

$$P_{\text{Reserve}} < P_{\text{ReserveIOP}}$$

If the reserve power exceeds the IOP reserve power threshold (parameter 5760) plus the hysteresis (parameter 5761) plus the rated load of the genset, the genset will be stopped. The hysteresis is intended to prevent frequent starting and stopping of gensets in case of small load variations.

$$P_{\text{Reserve}} > P_{\text{reserve isolatedIOP}} + P_{\text{hysteresis IOP}} + P_{\text{RatedGen}}$$

Mains Parallel Operation (mains import power control)

$$P_{Reserve} = P_{rated\ active} - P_{GN\ real\ active}$$

$$P_{rated\ active} = P_{RatedGen[1]} + P_{RatedGen[2]} + \dots + P_{RatedGen[n]} \text{ (total rated power of all gensets on the busbar in the system)}$$

$$P_{GN\ real\ active} = P_{ActualGen[1]} + P_{ActualGen[2]} + \dots + P_{ActualGen[n]} \text{ (total actual load of all gensets on the busbar in the system)}$$

If the required generator load set point for the control at the mains interchange point exceeds the MOP minimum load threshold (parameter 5767), the first genset will be added.

$$P_{MN\ setpoint} - P_{MN\ real} > P_{MOP\ minimum}$$

If at least one genset is supplying the load in parallel with the mains and the reserve power falls below the reserve power threshold (parameter 5768), another genset will be added.

$$P_{Reserve} < P_{reserve\ parallel}$$

If at least two gensets are supplying the load in parallel with the mains and the reserve power exceeds the MOP reserve power threshold (parameter 5768) plus the hysteresis (parameter 5769) plus the rated load of the genset, the genset will be stopped. The hysteresis is intended to prevent frequent starting and stopping of gensets in case of small load variations.

$$P_{Reserve} > P_{reserve\ parallel} + P_{hysteresis\ MOP} + P_{RatedGen}$$

If one genset is supplying the load in parallel with the mains and the generator load exceeds the MOP minimum load threshold (parameter 5767) minus the hysteresis (parameter 5769), the genset will be stopped. The hysteresis is intended to prevent frequent starting and stopping of gensets in case of small load variations.

$$P_{MN\ setpoint} - P_{MN\ real} + P_{GN\ real\ active} < P_{MOP\ minimum} - P_{hysteresis\ MOP}$$

Configure Application: Automatic, Load-Dependent Start/Stop: Generator Capacity Utilization

If the "Start stop mode" (parameter 5752 on page 198) is configured to "Generator load", load-dependent start stop is performed in a way that the next genset will be started if all gensets in operation reach the maximum generator load (parameter 5762 or 5770 "IOP/MOP Max. generator load"), a configured percentage (e.g. 80%) of the rated power. In order to stop one generator, the load of all gensets in operation must fall below the minimum generator load (parameter 5763 or 5771 "IOP/MOP Min. generator load"), a configured percentage (e.g. 30%) of the rated power. There are different set points for isolated and mains parallel operation.

An additional dynamic parameter (parameter 5757 or 5758 "IOP/MOP Dynamic") prevents the gensets from being started and stopped continuously if only a few gensets are in operation. Refer to the description of the dynamic parameters for detailed information.

This function provides an easy calculation for the start of the next genset.

The following parameters need to be configured for this operation:

Parameter ID	Parameter text	Note
5757	IOP Dynamic	only for isolated operation
5758	MOP Dynamic	only for mains parallel operation
5767	MOP Minimum load	only for mains parallel operation
5769	MOP Hysteresis	only for mains parallel operation
5770	MOP Max. generator load	only for mains parallel operation

Table 3-94: Load-dependent start/stop - parameters for generator load operation

Isolated Operation

If the configured maximum generator capacity utilization is exceeded, another genset will be added.

$$P_{GN \text{ real active}} > P_{\text{max. load isolated}}$$

If the configured minimum generator capacity utilization has been fallen below, a genset will be stopped depending on the dynamic setting. (refer to parameter 5757 on page 205 for detailed information).

$$P_{GN \text{ real active}} < P_{\text{min. load isolated}}$$

Mains Parallel Operation (mains import power control)

If the required generator load set point for the control at the mains interchange point exceeds the MOP minimum load threshold (parameter 5767), the first genset will be added.

$$P_{MN \text{ setpoint}} - P_{MN \text{ real}} > P_{MOP \text{ minimum}}$$

If at least one genset is supplying the load in parallel with the mains and the total generator load exceeds the MOP maximum generator load threshold (parameter 5770), another genset will be added.

$$P_{GN \text{ real active}} > P_{\text{max. load parallel}}$$

If at least two gensets are supplying the load in parallel with the mains and the configured minimum generator capacity utilization has been fallen below, a genset will be stopped depending on the dynamic setting. (refer to parameter 5758 on page 209 for detailed information)

$$P_{GN \text{ real active}} < P_{\text{min. load parallel}}$$

If one genset is supplying the load in parallel with the mains and the generator load exceeds the MOP minimum load threshold (parameter 5767) minus the hysteresis (parameter 5769), the genset will be stopped. The hysteresis is intended to prevent frequent starting and stopping of gensets in case of small load variations.

$$P_{MN \text{ setpoint}} - P_{MN \text{ real}} + P_{GN \text{ real active}} < P_{MOP \text{ minimum}} - P_{\text{hysteresis MOP}}$$

Configure Application: Automatic, Load-Dependent Start/Stop: Generator Selection

If a genset is to be started, the genset with the highest priority configured will be started. If a genset is to be stopped, the genset with the lowest priority configured will be stopped. If all gensets have the same priority, the next genset is selected according to the size of engine, i.e. the genset combination, which allows an optimum efficiency will be used. If all gensets have the same rated load or this parameter is disabled, the remaining hours until the next maintenance are considered. If these are also the same, the genset with the lowest generator number will be started first or stopped last.

Priority order:

1. Priority (parameter 5751)
2. Efficiency (size of engines) (parameter 5754)
3. Service hours (parameter 5755)
4. Generator (device) number (parameter 1702)

The load-dependent start/stop function requires the following conditions have been met:

- The control has been placed in AUTOMATIC operating mode
- A start request (Start req. in AUTO, Emergency run) is active
- All load sharing parameters are configured identically for all generators participating in load sharing (refer to Configure Monitoring: Miscellaneous, Multi-Unit on page 137)
- The mains interchange load control (import/export power) has been enabled or the gensets are in isolated operation
- The conditions of the *LogicsManager* function "Load-dependent start/stop" have been fulfilled

Parameter table

Level	Text	Setting range	Default value
Configure load dependent start/stop			
	LD start stop	<i>LogicsManager</i>	(0 & !04.27) & !00.19
	Start stop mode	Reserve power / Generator load	Reserve power
	Dead busbar start mode	All / LDSS	All
	Base priority	1 to 32	5
	LDSS priority 2	<i>LogicsManager</i>	(0 & 1) & 1
	LDSS priority 3	<i>LogicsManager</i>	(0 & 1) & 1
	LDSS priority 4	<i>LogicsManager</i>	(0 & 1) & 1
	Fit size of engines	Yes / No	No
	Fit service hours	Off / Equal / Staggered	Off
	Changes of engines	Off / All 32h / All 64h / All 128h	Off
	Minimum running time	0 to 32000 s	180 s

Table 3-95: Application - standard values - configure load dependent start/stop

EN	LD start stop	Lastabh. Zu/Abs.			
DE					
CL2	{0}	{1o}	{1oc}	{2oc}	
12930	✓	✓	✓	✓	

Load-dependent start stop

LogicsManager

Once the conditions of the *LogicsManager* have been fulfilled, the load-dependent start/stop function is enabled. The *LogicsManager* and its default settings are explained on page 273 in Appendix B: "*LogicsManager*".

EN	Start stop mode	Start Stop Modus			
DE					
CL2	{0}	{1o}	{1oc}	{2oc}	
5752	✓	✓	✓	✓	

Load-dependent start stop: Start stop mode

Reserve power / Generator load

Reserve power ..Load-dependent start stop is performed in a way that a configured minimum reserve power is maintained in the system. The reserve power is the total generator rated power minus the total actual generator power. If the reserve power falls below the threshold, another genset will be started. If the reserve power is sufficient to stop one genset without falling below the threshold, a genset will be stopped.

Generator load .Load-dependent start stop is performed in a way that a configured maximum generator capacity utilization is not exceeded. If the generator capacity utilization exceeds this threshold, another genset will be started. If the generator capacity utilization is low enough to stop one genset without exceeding the threshold again, a genset will be stopped.

EN	Dead busbar start mode	Schwarze Schiene Start Modus			
DE					
CL2	{0}	{1o}	{1oc}	{2oc}	
5753	✓	✓	✓	✓	

Load-dependent start stop: Dead busbar start mode

All / LDSS

All All available gensets will be started in case of a dead busbar and remain connected to the busbar for the minimum running time (parameter 5759). Then the gensets will be stopped according to the configured LDSS procedure. The start delay is configured in parameter 2800 (Mains fail delay time).

LDSS The start of the gensets will be performed according to the configured LDSS priority in case of a dead busbar.

Note: This function cannot be used as an emergency power function in mains parallel operations because it cannot control the MCB operation. If the MCB shall be operated, the emergency run function (parameter 2802) must be enabled

EN	Base priority			
DE	Grund Priorität			
CL2	{0}	{1o}	{1oc}	{2oc}
5751	✓	✓	✓	✓

Load-dependent start stop: Base priority

1 to 16

The priority of the genset in the load-dependent start/stop network is configured with this parameter (refer to Configure Application: Automatic, Load-Dependent Start/Stop: Generator Selection on page 197). The lower the number configured here, the higher the priority. This priority may be overridden by the LDSS Priority parameters (parameters 12924, 12925, and 12926).

EN	LDSS Priority 2			
DE	LZA Priorität 2			
CL2	{0}	{1o}	{1oc}	{2oc}
12926	✓	✓	✓	✓

Load-dependent start stop: Priority 2

LogicsManager

Once the conditions of the *LogicsManager* have been fulfilled, the load-dependent start/stop priority will be set to 2 (the highest priority is valid). The *LogicsManager* and its default settings are explained on page 273 in Appendix B: "*LogicsManager*".

EN	LDSS Priority 3			
DE	LZA Priorität 3			
CL2	{0}	{1o}	{1oc}	{2oc}
12925	✓	✓	✓	✓

Load-dependent start stop: Priority 3

LogicsManager

Once the conditions of the *LogicsManager* have been fulfilled, the load-dependent start/stop priority will be set to 3 (the highest priority is valid). The *LogicsManager* and its default settings are explained on page 273 in Appendix B: "*LogicsManager*".

EN	LDSS Priority 4			
DE	LZA Priorität 4			
CL2	{0}	{1o}	{1oc}	{2oc}
12924	✓	✓	✓	✓

Load-dependent start stop: Priority 4

LogicsManager

Once the conditions of the *LogicsManager* have been fulfilled, the load-dependent start/stop priority will be set to 4 (the highest priority is valid). The *LogicsManager* and its default settings are explained on page 273 in Appendix B: "*LogicsManager*".

EN	Fit size of engine			
DE	Auswahl nach Nennleistung			
CL2	{0}	{1o}	{1oc}	{2oc}
5754	✓	✓	✓	✓

Load-dependent start stop: Fit size of engine

Yes / No

This parameter defines whether the start/stop priority order (refer to Configure Application: Automatic, Load-Dependent Start/Stop: Generator Selection on page 197) considers the size of the engine (generator rated power) or not. In case of different sized gensets, the control can start a genset combination which results in optimum efficiency. The fuel efficiency may be optimized when this parameter is enabled. This parameter may be disabled if all generators have the same size.

Yes The priority order considers the engine size for the start of the next engine for gensets with the same priority.

No The priority order does not consider the rated power of the engines to fit the best size of engines.

		Fit service hours			
DE	EN	Auswahl nach Wartungsintervall			
CL2		{0}	{1o}	{1oc}	{2oc}
5755		✓	✓	✓	✓

Load-dependent start stop: Fit service hours

Off / Staggered / Equal

- Off**The remaining hours until the next service is required are not considered when evaluating the engines to be started.
- Staggered**The remaining hours until the next service is required are considered when evaluating the engines to be started for gensets with same priority. The gensets are utilized in a way that the maintenance may be performed at different times to ensure that not all gensets have a downtime due to a maintenance at the same time. The genset with the lowest hours until the next service will be started first.
- Equal**The remaining hours until the next service is required are considered when evaluating the engines to be started for gensets with same priority. The gensets are utilized in a way that the maintenance may be performed at the same time for all gensets. The genset with the highest hours until the next service will be started first.

EN	Changes of engines				
DE	Aggregatewechsel				
CL2	{0}	{1o}	{1oc}	{2oc}	
5756	✓	✓	✓	✓	

Load-dependent start stop: Changes of engines **Off / All 32h / All 64h / All 128h**

① This parameter is only effective if fit service hours (parameter 5755) is configured to "Equal".

Engine sequencing may be configured to start and stop engines according to the time remaining until the maintenance hours counter (parameter 2550) expires (counter reaches 0 hrs). The easYgen-2000 Series takes the time remaining on the maintenance hours counter and divides it by the service hours group (32/64/128 h) configured in this parameter to determine the individual unit's time group. A generator with a larger time group number has more time remaining before the maintenance hours timer expires and is considered to be the higher priority generator. If two generators are in the same time group, the configured generator number determines which generator is the higher priority and will be started first. This functionality enables the end user to have multiple generators due for service at approximately the same time.

- Off**..... No engine change will be performed. The engines are selected according to the setting of parameter 5755 (Fit service hours) with 1 hour spacing in case of load changes.
- All 32/64/128h** If parameter 5754 (Fit size of engine) is configured to "Yes", only engines with the same rated power and priority are changed, if it is configured to "No", engines with the same priority are changed depending on the service hours and generator number. All engines are divided into 32/64/128 service hour groups. An engine change is performed if one engine changes to another group in 32/64/128 hour spacing.

Example 1: "Changes of engines" is configured to "All 64h"
 Generator 1 has 262 maintenance hours remaining
 Generator 2 has 298 maintenance hours remaining

The time group for generator 1 is calculated as: $262h/64h = 4.09 =$ Time group 4
 The time group for generator 2 is calculated as: $298h/64h = 4.66 =$ Time group 4

Both generators are in time group 4. Time group 4 consists of any generator that the time group calculation total ranges from 4.00 through 4.99. In this instance the assigned generator number is used to determine which generator is brought online. Generator 1 will be started.

Example 2: "Changes of engines" is configured to "All 64h"
 Generator 1 has 262 maintenance hours remaining
 Generator 2 has 345 maintenance hours remaining
 Generator 3 has 298 maintenance hours remaining

The time group for generator 1 is calculated as: $262h/64h = 4.09 =$ Time group 4
 The time group for generator 2 is calculated as: $345h/64h = 5.39 =$ Time group 5
 The time group for generator 3 is calculated as: $298h/64h = 4.66 =$ Time group 4

Generators 1 and 3 are in time group 4. Time group 4 consists of any generator that the time group calculation total ranges from 4.00 through 4.99. Generator 2 is in time group 5. Time group 5 consists of any generator that the time group calculation total ranges from 5.00 through 5.99. In this instance the largest time group will determine which generator is brought online. Generator 2 will be started because it is in time group 5.

DE	Minimum running time			
	Aggregate Mindestlaufzeit			
EN	{0}	{1o}	{1oc}	{2oc}
CL2	✓	✓	✓	✓
5759				

Load-dependent start stop: Minimum running time **0 to 32000 s**

If a genset has been started by the LDSS function, it continues to operate at least for this time even if it would have been stopped before. This timer is started with the closure of the GCB. If an emergency run is active (refer to Configure Application: Configure Emergency Run on page 191) and the mains return, this timer will be overridden and the load is transferred back to the mains after the mains settling time (parameter 2801 on page 85) has expired.

Configure Application: Automatic, Load-Dependent Start/Stop: Isolated Parallel Operation (IOP)

In case of an isolated parallel operation (MCB open), the first genset will be connected to the de-energized busbar. At least one genset must be in operation in isolated operation. There are dedicated LDSS parameters for isolated parallel operation because the supply of the load is important here.

Parameter table

Level	Text	Setting range	Default value
Configure load dependent start/stop isolated operation			
	IOP Reserve power	1 to 999999 kW	100 kW
	IOP Hysteresis	5 to 65000 kW	20 kW
	IOP Max. generator load	0 to 100 %	70 %
	IOP Min. generator load	0 to 100 %	30 %
	IOP Dynamic	Low / Moderate / High	Low
	IOP Add on delay	0 to 32000 s	10 s
	IOP Add on delay at rated load	0 to 32000 s	3 s
	IOP Add off delay	0 to 32000 s	60 s

Table 3-96: Application - standard values - configure load dependent start/stop IOP

EN	IOP Reserve power	Load-dependent start stop: IOP Reserve power	0 to 999999 kW
DE	IPB Reserveleistung		
CL2	{0} {1o} {1oc} {2oc}	ⓘ This parameter is only effective if start stop mode (parameter 5752) is configured to "Reserve power".	
5760	✓ ✓ ✓ ✓		

The value configured for the reserve power determines when an additional generator will be started. The reserve power is the desired spinning reserve of a generator or generators. The reserve power is usually estimated as the largest load swing that a power plant may encounter during the time it takes to bring an additional generator online. The available generator power is calculated by adding up the generator real power ratings of all generators with closed GCBs. The reserve generator power is calculated by subtracting the power currently being produced by all generators with closed GCBs from the total available generator power. If the actual reserve power of the generators is less than the value configured in this parameter, the next generator will be started.

$$\begin{aligned}
 &\text{Currently available total generator rated real power} \\
 &- \text{Currently available total generator actual real power} \\
 &= \text{Reserve power}
 \end{aligned}$$

EN	IOP Hysteresis	Load-dependent start stop: IOP Hysteresis	0 to 65000 kW
DE	IPB Hysterese		
CL2	{0} {1o} {1oc} {2oc}	ⓘ This parameter is only effective if start stop mode (parameter 5752) is configured to "Reserve power".	
5761	✓ ✓ ✓ ✓		

If the reserve power is sufficient to stop one genset without falling below the threshold and the hysteresis configured here, a genset will be stopped.

EN	IOP Max. generator load	Load-dependent start stop: IOP Maximum generator load	0 to 100 %
DE	IPB Max. Generatorlast		
CL2	{0} {1o} {1oc} {2oc}	ⓘ This parameter is only effective if start stop mode (parameter 5752) is configured to "Generator load".	
5762	✓ ✓ ✓ ✓		

If the generator load exceeds the threshold configured here, the load-dependent start/stop function will start another genset.

IOP Min. generator load	
IPB Min. Generatorlast	
CL2	{0} {1o} {1oc} {2oc}
5763	✓ ✓ ✓ ✓

Load-dependent start stop: IOP Minimum generator load 0 to 100 %

i This parameter is only effective if start stop mode (parameter 5752) is configured to "Generator load".

If the generator load falls below the threshold configured here, the load-dependent start/stop function will stop a genset. If only a few gensets are operating in a multi-genset application, the IOP Dynamic (parameter 5757 on page 205) will also be considered when stopping a genset.



NOTE

The maximum generator load must be configured higher than the minimum generator load for proper operation.

EN	IOP Dynamic				
DE	IPB Dynamik				
CL2 5757	{0} ✓	{1o} ✓	{1oc} ✓	{2oc} ✓	

Load-dependent start stop: IOP Dynamic

Low / Moderate / High

ⓘ This parameter is only effective if start stop mode (parameter 5752) is configured to "Generator load".

The dynamic determines when to start or stop the next genset and shows the following behavior:

Starting a genset:

The Dynamic is only considered for the start sequence if "Fit size of engines" is enabled (refer to parameter 5754). The control requests a certain amount of additional load depending on the dynamic. It may start two or more gensets to supply the required load. Also refer to the following example.

- Low**A larger genset is requested and it will take longer until the next change is required. The engines are operated with more reserve power.
The requested load is calculated so that the gensets will be loaded with 25 % of the range between minimum and maximum generator load (parameters 5762 & 5763) after the new genset has been started.
- Moderate**A medium genset is requested.
The requested load is calculated so that the gensets will be loaded with 50 % of the range between minimum and maximum generator load (parameters 5762 & 5763) after the new genset has been started.
- High**A smaller genset is requested to operate the engines with higher efficiency. This may lead to more frequent starts and stops.
The requested load is calculated so that the gensets will be loaded with 75 % of the range between minimum and maximum generator load (parameters 5762 & 5763) after the new genset has been started.

Stopping a genset:

The dynamic determines how soon a genset will be stopped. It prevents continuous start and stop if only a few gensets are in operation. In this case, the remaining gensets would not reach the maximum limit if one genset stops (if, for example, two gensets with 100 kW rated load, a minimum load of 40 % and a maximum load of 70 % are operated, the second genset will be shut down if both reach 40 kW and the remaining engine would operate with 80 kW and request the next engine and so on). The more gensets are running, the less the influence of this parameter. Also refer to the following example.

- Low**The genset will shut down at a lower limit and be operated longer.
The number of gensets in operation will remain constant for a wider range of load.
The load on the remaining gensets must not exceed 25 % of the range between minimum and maximum generator load (parameters 5762 & 5763).
- Moderate**The load on the remaining gensets must not exceed 50 % of the range between minimum and maximum generator load (parameters 5762 & 5763).
- High**The genset will be shut down earlier. This may lead to more frequent starts and stops.
The load on the remaining gensets must not exceed 75 % of the range between minimum and maximum generator load (parameters 5762 & 5763).

Example for starting a genset:

A plant made up of several gensets with a rated power of 50, 100, and 200 kW is configured to a maximum generator load of 70 % and a minimum generator load of 40 %. One genset with 200 kW is running and the actual load reaches 140 kW. This is the 70 % maximum load limit of the running genset and requires the start of the next genset.

- If the dynamic is configured to Low, a total generator rated power of 294.7 kW is requested and a 100 kW genset will be started.
- If the dynamic is configured to Moderate, a total generator rated power of 254.5 kW is requested and a 100 kW genset will be started.
- If the dynamic is configured to High, a total generator rated power of 224.0 kW is requested and a 50 kW genset will be started.

Refer to Appendix G: LDSS Formulas on page 334 for details about the formulas used for calculation.

Example for stopping a genset:

Two gensets with the same rated power are configured to a maximum generator load of 70 % and a minimum generator load of 40 %. Table 3-97 shows the load level before stopping the second genset and the resulting load level for the first genset depending on the dynamic setting.

Dynamic	Load level before stopping	Resulting load level for remaining engine
Low	23.75 %	47.5 % (25 % of the difference between 70 and 40 %)
Moderate	27.5 %	55 % (50 % of the difference between 70 and 40 %)
High	31.25 %	62.5 % (75 % of the difference between 70 and 40 %)

Table 3-97: Load-dependent start/stop - dynamic influence on stopping a genset

EN	IOP Add on delay				
DE	IPB Zusatzverzögerung				
CL2	{0}	{1o}	{1oc}	{2oc}	
5764	✓	✓	✓	✓	

Load-dependent start stop: IOP Add on delay **0 to 32000 s**

Load swings may exceed the threshold momentarily. In order to prevent the engine from starting due to short-term load swings, a delay time may be configured. The LDSS criterion for adding load must be exceeded without interruption for this delay time, configured in seconds, prior to a start command being issued. If the LDSS criterion for adding load is fallen below before the delay time expires, the delay time is reset and a start command is not issued.

EN	IOP Add on delay at rated load				
DE	IPB Zusatzverzög. bei Nennlast				
CL2	{0}	{1o}	{1oc}	{2oc}	
5765	✓	✓	✓	✓	

Load-dependent start stop: IOP Add on delay at rated load **0 to 32000 s**

The command to start the next genset in case a genset exceeds rated load will be issued after the delay configured here has expired. This parameter becomes only effective in case a genset exceeds rated load to achieve a faster start and overrides parameter 5764.

EN	IOP Add off delay				
DE	IPB Absetzverzögerung				
CL2	{0}	{1o}	{1oc}	{2oc}	
5766	✓	✓	✓	✓	

Load-dependent start stop: IOP Add off delay **0 to 32000 s**

Load swings may fall below the threshold momentarily. In order to prevent the engine from stopping due to short-term load swings, a delay time may be configured. The load must remain below the hysteresis set point without interruption for the delay time, configured in seconds, prior to a stop command being issued. If the load exceeds the hysteresis set point before the delay time expires, the delay time is reset and a stop command is not issued.

Configure Application: Automatic, Load-Dependent Start/Stop: Mains Parallel Operation (MOP)

In case of a mains parallel operation (MCB closed), load-dependent start stop is only enabled, if the gensets participates in load sharing at the interchange point (all participating gensets must be configured to the same set point). A minimum load threshold must be exceeded to start the first genset, i.e. a genset will only be started if a minimum load would be demanded from the generator. There are dedicated LDSS parameters for mains parallel operation.

Parameter table

Level	Text	Setting range	Default value
Configure load dependent start/stop mains parallel operation			
	MOP Minimum load	0 to 65000 kW	10 kW
	MOP Reserve power	1 to 999999 kW	50 kW
	MOP Hysteresis	0 to 65000 kW	20 kW
	MOP Max. generator load	0 to 100 %	70 %
	MOP Min. generator load	0 to 100 %	30 %
	MOP Dynamic	Low / Moderate / High	Low
	MOP Add on delay	0 to 32000 s	20 s
	MOP Add on delay at rated load	0 to 32000 s	3 s
	MOP Add off delay	0 to 32000 s	60 s

Table 3-98: Application - standard values - configure load dependent start/stop MOP

EN	MOP Minimum load	Load-dependent start stop: MOP Minimum load	0 to 65000 kW
DE	NPB Mindestlast		
CL2	{0} {1o} {1oc} {2oc}		
5767	✓ ✓ ✓ ✓		

For the mains interchange (import/export) real power control to function, a minimum generator power set point value is required to start the first genset. In many cases, it is desirable that the engine is prevented from starting unless the generator will operate at a specific kW level or higher to ensure a reasonable degree of efficiency.

Example: The mains interchange must reach a level that will permit an 80kW generator to operate at a minimum load of 40kW prior to the engine starting.

EN	MOP Hysteresis	Load-dependent start stop: MOP Hysteresis	0 to 65000 kW
DE	NPB Hysterese		
CL2	{0} {1o} {1oc} {2oc}	① The importance of this parameter depends on the setting of the start stop mode (parameter 5752).	
5769	✓ ✓ ✓ ✓		

Start stop mode configured to "Reserve power": If the reserve power is sufficient to stop one genset without falling below the reserve power threshold and the hysteresis configured here, a genset will be stopped.

If the generator load falls below the minimum load threshold minus the hysteresis configured here, the last genset will be stopped.

EN	MOP Reserve power	Load-dependent start stop: MOP Reserve power	0 to 999999 kW
DE	NPB Reserveleistung		
CL2	{0} {1o} {1oc} {2oc}	① This parameter is only effective if start stop mode (parameter 5752) is configured to "Reserve power".	
5768	✓ ✓ ✓ ✓		

The minimum reserve power in mains parallel operation is configured here. This is the maximum expected load swing on the busbar, which shall be supported by the gensets. If the reserve power falls below this value, the load-dependent start/stop function will start another genset.

EN	MOP Max. generator load			
DE	NPB Max. Generatorlast			
CL2	{0}	{1o}	{1oc}	{2oc}
5770	✓	✓	✓	✓

Load-dependent start stop: MOP Maximum generator load **0 to 100 %**

ⓘ This parameter is only effective if start stop mode (parameter 5752) is configured to "Generator load".

If the generator load exceeds the threshold configured here, the load-dependent start/stop function will start another genset.

EN	MOP Min. generator load			
DE	NPB Min. Generatorlast			
CL2	{0}	{1o}	{1oc}	{2oc}
5771	✓	✓	✓	✓

Load-dependent start stop: MOP Minimum generator load **0 to 100 %**

ⓘ This parameter is only effective if start stop mode (parameter 5752) is configured to "Generator load".

If the generator load falls below the threshold configured here, the load-dependent start/stop function will stop a genset. If only a few gensets are operating in a multi-genset application, the MOP Dynamic (parameter 5758) will also be considered when stopping a genset.



NOTE

The maximum generator load must be configured higher than the minimum generator load for proper operation.

EN	MOP Dynamic				
DE	NPB Dynamik				
	CL2 5758	{0} ✓	{1o} ✓	{1oc} ✓	{2oc} ✓

Load-dependent start stop: MOP Dynamic

Low / Moderate / High

ⓘ This parameter is only effective if start stop mode (parameter 5752) is configured to "Generator load".

The dynamic determines when to start or stop the next genset and shows the following behavior:

Starting a genset:

The Dynamic is only considered for the start sequence if "Fit size of engines" is enabled (refer to parameter 5754). The control requests a certain amount of additional load depending on the dynamic. It may start two or more gensets to supply the required load.

- Low**A larger genset is requested and it will take longer until the next change is required. The engines are operated with more reserve power.
The requested load is calculated so that the gensets will be loaded with 25 % of the range between minimum and maximum generator load (parameters 5762 & 5763) after the new genset has been started.
- Moderate**A medium genset is requested.
The requested load is calculated so that the gensets will be loaded with 50 % of the range between minimum and maximum generator load (parameters 5762 & 5763) after the new genset has been started.
- High**A smaller genset is requested to operate the engines with higher efficiency. This may lead to more frequent starts and stops.
The requested load is calculated so that the gensets will be loaded with 75 % of the range between minimum and maximum generator load (parameters 5762 & 5763) after the new genset has been started.

Stopping a genset:

The dynamic determines how soon a genset will be stopped. It prevents continuous start and stop if only a few gensets are in operation. In this case, the remaining gensets would not reach the maximum limit if one genset stops (if, for example, two gensets with 100 kW rated load, a minimum load of 40 % and a maximum load of 70 % are operated, the second genset will be shut down if both reach 40 kW and the remaining engine would operate with 80 kW and request the next engine and so on). The more gensets are running, the less the influence of this parameter. Also refer to the following example.

- Low**The genset will shut down at a lower limit and be operated longer.
The number of gensets in operation will remain constant for a wider range of load.
The load on the remaining gensets must not exceed 25 % of the range between minimum and maximum generator load (parameters 5762 & 5763).
- Moderate**The load on the remaining gensets must not exceed 50 % of the range between minimum and maximum generator load (parameters 5762 & 5763).
- High**The genset will be shut down earlier. This may lead to more frequent starts and stops.
The load on the remaining gensets must not exceed 75 % of the range between minimum and maximum generator load (parameters 5762 & 5763).

Refer to parameter 5757 on page 205 for examples on starting and stopping a genset depending on the dynamic setting.

EN	MOP Add on delay				Load-dependent start stop: MOP Add on delay	0 to 32000 s
DE	NPB Zusatzverzögerung					
CL2	{0}	{10}	{100}	{200}	Load swings may exceed the threshold momentarily. In order to prevent the engine from starting due to short-term load swings, a delay time may be configured. The LDSS criterion for adding load must be exceeded without interruption for this delay time, configured in seconds, prior to a start command being issued. If the LDSS criterion for adding load is fallen below before the delay time expires, the delay time is reset and a start command is not issued.	
5772	✓	✓	✓	✓		

EN	MOP Add on delay at rated load				Load-dependent start stop: MOP Add on delay at rated load	0 to 32000 s
DE	NPB Zusatzverzög. bei Nennlast					
CL2	{0}	{10}	{100}	{200}	The command to start the next genset in case a genset exceeds rated load will be issued after the delay configured here has expired. This parameter becomes only effective in case a genset exceeds rated load to achieve a faster start and overrides parameter 5772.	
5773	✓	✓	✓	✓		

EN	MOP Add off delay				Load-dependent start stop: MOP Add off delay	0 to 32000 s
DE	NPB Absetzverzögerung					
CL2	{0}	{10}	{100}	{200}	Load swings may fall below the threshold momentarily. In order to prevent the engine from stopping due to short-term load swings, a delay time may be configured. The load must remain below the hysteresis set point without interruption for the delay time, configured in seconds, prior to a stop command being issued. If the load exceeds the hysteresis set point before the delay time expires, the delay time is reset and a stop command is not issued.	
5774	✓	✓	✓	✓		

Configure Application: Automatic, Start w/o Load (*LogicsManager*)

EN	Start w/o load			
DE	Start ohne Übernahme			
CL2	{0}	{1o}	{1oc}	{2oc}
12540	---	---	✓	✓

Start without assuming load

LogicsManager

If this *LogicsManager* condition is TRUE switching from mains to generator supply following an engine start is prevented (the GCB close operation is blocked). This function may be used to perform a test operation. If an emergency power case occurs meanwhile, it is still possible to change to generator operation. If this condition becomes TRUE in isolated operation, the GCB cannot be opened before the MCB has been closed. The *LogicsManager* and its default settings are explained on page 273 in Appendix B: "*LogicsManager*".

Configure Application: Automatic, Operation Modes

EN	Startup in mode			
DE	Einschalten in Betriebsart			
CL2	{0}	{1o}	{1oc}	{2oc}
1795	---	---	✓	✓

Operating mode after applying the power supply

STOP / AUTO / MAN / Last

If the controller is powered down, the unit will start in the following configured mode when it is powered up again.

STOP The unit starts in the STOP operating mode.

AUTO The unit starts in the AUTOMATIC operating mode.

MAN The unit starts in the MANUAL operating mode.

Last The unit starts in the last operating mode the control was in prior to being de-energized.



NOTE

For the selection of the operating mode via the *LogicsManager* (if two different operating modes have been selected simultaneously) the control unit will prioritize the modes as follows:

1. STOP
2. MANUAL
3. AUTOMATIC

EN	Operat. mode AUTO			
DE	Betriebsart AUTO			
CL2	{0}	{1o}	{1oc}	{2oc}
12510	✓	✓	✓	✓

Activate operating mode AUTOMATIC

LogicsManager

Once the conditions of the *LogicsManager* have been fulfilled the unit will change into operating mode AUTOMATIC. If AUTOMATIC mode is selected via the *LogicsManager* it is not possible to change operating modes via the front panel. The *LogicsManager* and its default settings are explained on page 273 in Appendix B: "*LogicsManager*".

EN	Operat. mode MAN			
DE	Betriebsart MAN			
CL2	{0}	{1o}	{1oc}	{2oc}
12520	✓	✓	✓	✓

Activate operating mode MANUAL

LogicsManager

Once the conditions of the *LogicsManager* have been fulfilled the unit will change into operating mode MANUAL. If MANUAL mode is selected via the *LogicsManager* it is not possible to change operating modes via the front panel. The *LogicsManager* and its default settings are explained on page 273 in Appendix B: "*LogicsManager*".

EN	Operat. mode STOP			
DE	Betriebsart STOP			
CL2	{0}	{1o}	{1oc}	{2oc}
12530	✓	✓	✓	✓

Activate operating mode STOP

LogicsManager

Once the conditions of the *LogicsManager* have been fulfilled the unit will change into operating mode STOP. If STOP mode is selected via the *LogicsManager* it is not possible to change operating modes via the front panel. The *LogicsManager* and its default settings are explained on page 273 in Appendix B: "*LogicsManager*".

Configure Application: Automatic, Critical Mode (Sprinkler Operation, *LogicsManager*)

The critical mode may be used to operate a fire engine pump or any other critical operation which does not allow a shutdown of the genset under any alarm conditions. The *LogicsManager* is used to define the conditions that will enable the critical mode like a discrete input (for conditions and explanation of programming refer to *Configure LogicsManager* on page 265).

Alarm Classes

When critical mode is enabled the alarm classes are reclassified as follows:

	Alarm classes					
Normal operation	A	B	C	D	E	F
Critical mode	A	B	B	B	B	B

Critical mode "On"

A critical mode will be initiated/started once the critical mode operation *LogicsManager* output becomes TRUE (logic "1"). The "Critical mode" message is displayed on the display screen. If the engine is not already running, the controller will attempt to start the engine as configured (parameter 4102 on page 184). All shutdown alarms become warning messages (see above).

Critical mode "Off"

A critical mode will be interrupted/stopped once critical mode operation *LogicsManager* output becomes FALSE (logic "0") and the postrun time has expired. If the operation mode changes to STOP, this time will be considered as expired. With termination of the critical mode, a normal cool down is performed.



NOTE

Refer to Priority Hierarchy of the Logical Outputs on page 277 for more information about the priorities of the logical outputs.

Critical Operation (Sprinkler) Connected to the Busbar

Aforementioned fire engine pump or other critical operation is connected to the busbar, i.e. it requires a closed GCB to be supplied by the generator during critical operation. Parameter 4100 (Close GCB in critical mode) should be configured to "Yes" and an external provision for load reduction should be provided. This ensures the pump operation of a sprinkler system.

Application and breaker transition mode remain as configured. A mains parallel operation is possible.

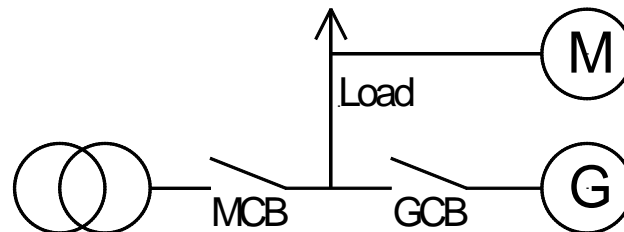

Figure 3-26: Automatic - Critical operation at busbar



NOTE

The GCB will not be closed if the load is supplied by the mains until the mains fail and the MCB remains closed because emergency run (parameter 2802) is disabled.

Critical Mode During Mains Supply

If critical mode is enabled during mains supply (MCB is closed), the generator will be started (if not already running) and the GCB will be closed. The "Critical mode" message is displayed on the display screen. All shutdown alarms become warning messages.

If critical mode is disabled again, all shutdown alarms become active again. If the genset was not running before critical mode has been enabled, it will be stopped after the critical mode postrun time (parameter 4102) has expired. MCB operation will be performed according to the configured transition mode.

Emergency Power During Critical Mode

If there is a mains failure during critical mode, the "**Emerg/Critical**" message is displayed on the display screen after the mains fail delay time (parameter 2800) has expired. All shutdown alarms become warning messages.

- ⇒ Critical mode ends before mains recovery: The emergency power operation will be continued and all shutdown alarms become active again. If the mains return, the unit transfers the load from generator supply to mains supply after the mains settling delay expires.
- ⇒ Emergency power operation ends before the end of the critical mode: The critical mode is maintained and the load is transferred from generator supply to mains supply after the mains settling delay expires. The engine remains running until the conditions for the critical mode are no longer existent. If the genset was not running before critical mode has been enabled, it will be stopped after cool down time (parameter 3316) has expired. The GCB will take on the same state as it has before the critical mode has been enabled.

Critical Mode During Emergency Power

An emergency power operation is active (load is supplied by the generator, GCB is closed, MCB is open). If critical mode is enabled now, the GCB remains closed and the "**Emerg/Critical**" message is displayed on the display screen. All shutdown alarms become warning messages.

- ⇒ Critical mode ends before mains recovery: The emergency power operation will be continued and all shutdown alarms become active again. If the mains return, the unit transfers the load from generator supply to mains supply after the mains settling delay expires, if Enable MCB (parameter 12923) has been enabled.
- ⇒ Emergency power operation ends before the end of the critical mode: The critical mode is maintained and the load is transferred from generator supply to mains supply after the mains settling delay expires. The engine remains running until the conditions for the critical mode are no longer existent. If the genset was not running before critical mode has been enabled, it will be stopped after cool down time (parameter 3316) has expired. The GCB will take on the same state as it has before the critical mode has been enabled.

Start Request During Critical Mode

The critical mode operation has priority than the remote request (Start/Stop request in AUTO). Therefore, the remote request cannot start or stop the engine and has no effect on the breaker positions. The "**Critical mode**" message is displayed on the display screen and all shutdown alarms become warning alarms.

- ⇒ Critical mode ends before the start request is terminated: The engine continues running. All shutdown alarms will become active again. By resetting the start request the GCB will be opened and the engine will be stopped.
- ⇒ Start request will be terminated before the critical mode is terminated: The critical mode operation is continued. The engine keeps running until the conditions for the critical mode are no longer fulfilled and all shutdown alarms will become active again. If the genset was not running before critical mode has been enabled, it will be stopped after cool down time (parameter 3316) has expired. The GCB will take on the same state as it has before the critical mode has been enabled.
- ⇒ Critical mode and start request: The generator is supplying load in automatic mode with closed GCB. If critical mode is enabled, the "**Critical mode**" message is displayed on the display screen and all shutdown alarms become warning alarms.

Critical Operation (Sprinkler) Connected to the Generator

Aforementioned fire engine pump or other critical operation is connected to the generator, i.e. it does not require a closed GCB to be supplied by the generator during critical operation. Parameter 4100 (Close GCB in critical mode) should be configured to "No". This ensures an open GCB during critical mode. A closed GCB is possible in case of an emergency operation.

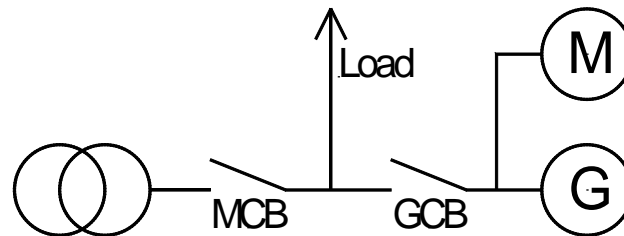

Figure 3-27: Automatic - Critical operation at generator

Critical Mode During Mains Supply

If critical mode is enabled during mains supply (MCB is closed), the generator will be started (if not already running) and operated at idle speed (GCB is open). The "**Critical mode**" message is displayed on the display screen. All shutdown alarms become warning messages.

If critical mode is disabled again, all shutdown alarms become active again. If the genset was not running before critical mode has been enabled, it will be stopped after the critical mode postrun time (parameter 4102) has expired.

Emergency Power During Critical Mode

If there is a mains failure during critical mode, the MCB will be opened after the mains fail delay time (parameter 2800) has expired and the GCB will be closed. It is not necessary to configure parameter 4101 (Break emerg. in critical mode) because the critical operation is already supplied. The "**Emerg/Critical**" message is displayed on the display screen and all shutdown alarms become warning messages.

- ⇒ Critical mode ends before mains recovery: The emergency power operation will be continued and all shutdown alarms become active again. If the mains return, the unit transfers the load from generator supply to mains supply after the mains settling delay expires.
- ⇒ Emergency power operation ends before the end of the critical mode: The critical mode is maintained and the load is transferred from generator supply to mains supply after the mains settling delay expires. The GCB will be opened without unloading (transition mode interchange or parallel). If open transition mode is configured, the GCB will not be opened to prevent a dead busbar. All shutdown alarms become active again. If the genset was not running before critical mode has been enabled, it will be stopped after cool down time (parameter 3316) has expired.

Critical Mode During Emergency Power

An emergency power operation is active (load is supplied by the generator, GCB is closed, MCB is open). If critical mode is enabled now, the GCB will be opened dependent on the setting of the parameter 4101 (Break emerg. in critical mode) and a closure of the GCB is prevented for this time. The "**Emerg/Critical**" message is displayed on the display screen and all shutdown alarms become warning messages.

- ⇒ Critical mode ends before mains recovery: The emergency power operation will be continued and all shutdown alarms become active again. If the mains return, the unit transfers the load from generator supply to mains supply after the mains settling delay expires.
- ⇒ Emergency power operation ends before the end of the critical mode: The critical mode is maintained and the load is transferred from generator supply to mains supply after the mains settling delay expires. The GCB will be opened without unloading (transition mode interchange or parallel). All shutdown alarms become active again. If the genset was not running before critical mode has been enabled, it will be stopped after cool down time (parameter 3316) has expired.

Start Request During Critical Mode

The critical mode operation has priority than the remote request (Start/Stop request in AUTO). Therefore, the remote request cannot start or stop the engine and has no effect on the breaker positions. The "**Critical mode**" message is displayed on the display screen and all shutdown alarms become warning alarms.

- ⇒ Critical mode ends before the start request is terminated: The engine continues running and a change to generator or parallel operation is performed. All shutdown alarms will become active again.
- ⇒ Start request will be terminated before the critical mode is terminated: The critical mode operation is continued. The engine keeps running until the conditions for the critical mode are no longer fulfilled and all shutdown alarms will become active again. If the genset was not running before critical mode has been enabled, it will be stopped after cool down time (parameter 3316) has expired. The GCB will take on the same state as it has before the critical mode has been enabled.

Critical Mode During Start Request

The generator supplies the load and the GCB is closed. If critical mode is enabled, the MCB will be operated according to the configured transition mode (parameter 3411). The GCB will be opened without unloading (transition mode interchange or parallel). The "**Critical mode**" message is displayed on the display screen and all shutdown alarms become warning alarms.

- ⇒ Critical mode ends before the start request is terminated: The engine continues running and a change to generator or parallel operation is performed. All shutdown alarms will become active again.
- ⇒ Start request will be terminated before the critical mode is terminated: The critical mode operation is continued. The engine keeps running until the conditions for the critical mode are no longer fulfilled and all shutdown alarms will become active again. If the genset was not running before critical mode has been enabled, it will be stopped after cool down time (parameter 3316) has expired.

Critical mode During Isolated Operation

The busbar is supplied by the generator and emergency run (parameter 2802) is disabled. If the critical mode is enabled, the GCB will be opened although the MCB is not enabled. This will cause a dead busbar.

Parameters

Parameter table

Level	Text	Setting range	Default value
Configure critical mode			
	Critical mode	<i>LogicsManager</i>	(0 & !05.08) & !09.01
	Critical mode postrun	0 to 6000 s	600 s
	Close GCB in critical mode	Yes / No	No
	Critical mode alarm class MAN	Yes / No	No

Table 3-99: Application - standard values - configure critical mode

If this logical output becomes TRUE in AUTOMATIC operating mode, it starts the critical mode.

<table border="0"> <tr> <td>EN</td> <td></td> <td colspan="4">Critical mode</td> <td>Critical mode request</td> <td><i>LogicsManager</i></td> </tr> <tr> <td>DE</td> <td></td> <td colspan="4">Sprinklerbetrieb</td> <td></td> <td></td> </tr> <tr> <td>CL2</td> <td>{0}</td> <td>{1o}</td> <td>{1oc}</td> <td>{2oc}</td> <td></td> <td></td> </tr> <tr> <td>12220</td> <td>✓</td> <td>✓</td> <td>✓</td> <td>✓</td> <td>The <i>LogicsManager</i> and its default settings are explained on page 273 in Appendix B: "<i>LogicsManager</i>".</td> <td></td> </tr> </table>	EN		Critical mode				Critical mode request	<i>LogicsManager</i>	DE		Sprinklerbetrieb						CL2	{0}	{1o}	{1oc}	{2oc}			12220	✓	✓	✓	✓	The <i>LogicsManager</i> and its default settings are explained on page 273 in Appendix B: " <i>LogicsManager</i> ".		<hr/>						
EN		Critical mode				Critical mode request	<i>LogicsManager</i>																														
DE		Sprinklerbetrieb																																			
CL2	{0}	{1o}	{1oc}	{2oc}																																	
12220	✓	✓	✓	✓	The <i>LogicsManager</i> and its default settings are explained on page 273 in Appendix B: " <i>LogicsManager</i> ".																																
<table border="0"> <tr> <td>EN</td> <td></td> <td colspan="4">Critical mode postrun</td> <td>Critical mode postrun time</td> <td>0 to 6000 s</td> </tr> <tr> <td>DE</td> <td></td> <td colspan="4">Sprinkler Nachlaufzeit</td> <td></td> <td></td> </tr> <tr> <td>CL2</td> <td>{0}</td> <td>{1o}</td> <td>{1oc}</td> <td>{2oc}</td> <td></td> <td></td> </tr> <tr> <td>4109</td> <td>✓</td> <td>✓</td> <td>✓</td> <td>✓</td> <td>The critical mode operation is continued for the time configured here after the critical mode request has been terminated. The message "Cool down" is displayed and the <i>LogicsManager</i> command variable 04.10 becomes TRUE.</td> <td></td> </tr> </table>	EN		Critical mode postrun				Critical mode postrun time	0 to 6000 s	DE		Sprinkler Nachlaufzeit						CL2	{0}	{1o}	{1oc}	{2oc}			4109	✓	✓	✓	✓	The critical mode operation is continued for the time configured here after the critical mode request has been terminated. The message " Cool down " is displayed and the <i>LogicsManager</i> command variable 04.10 becomes TRUE.		<hr/>						
EN		Critical mode postrun				Critical mode postrun time	0 to 6000 s																														
DE		Sprinkler Nachlaufzeit																																			
CL2	{0}	{1o}	{1oc}	{2oc}																																	
4109	✓	✓	✓	✓	The critical mode operation is continued for the time configured here after the critical mode request has been terminated. The message " Cool down " is displayed and the <i>LogicsManager</i> command variable 04.10 becomes TRUE.																																
<table border="0"> <tr> <td>EN</td> <td></td> <td colspan="4">Close GCB in critical mode</td> <td>Close GCB in critical mode</td> <td>Yes / No</td> </tr> <tr> <td>DE</td> <td></td> <td colspan="4">GLS schließen bei Sprinkler</td> <td></td> <td></td> </tr> <tr> <td>CL2</td> <td>{0}</td> <td>{1o}</td> <td>{1oc}</td> <td>{2oc}</td> <td></td> <td></td> </tr> <tr> <td>4100</td> <td>---</td> <td>---</td> <td>✓</td> <td>✓</td> <td>Yes If a critical mode operation is detected the GCB will close. No The GCB cannot be closed during a critical mode operation.</td> <td></td> </tr> </table>	EN		Close GCB in critical mode				Close GCB in critical mode	Yes / No	DE		GLS schließen bei Sprinkler						CL2	{0}	{1o}	{1oc}	{2oc}			4100	---	---	✓	✓	Yes If a critical mode operation is detected the GCB will close. No The GCB cannot be closed during a critical mode operation.		<hr/>						
EN		Close GCB in critical mode				Close GCB in critical mode	Yes / No																														
DE		GLS schließen bei Sprinkler																																			
CL2	{0}	{1o}	{1oc}	{2oc}																																	
4100	---	---	✓	✓	Yes If a critical mode operation is detected the GCB will close. No The GCB cannot be closed during a critical mode operation.																																
<table border="0"> <tr> <td>EN</td> <td></td> <td colspan="4">Override alarmcl. also in MAN</td> <td>Critical mode alarm classes active in MANUAL operating mode</td> <td>Yes / No</td> </tr> <tr> <td>DE</td> <td></td> <td colspan="4">Sprinkler Alarmkl. in MAN</td> <td></td> <td></td> </tr> <tr> <td>CL2</td> <td>{0}</td> <td>{1o}</td> <td>{1oc}</td> <td>{2oc}</td> <td></td> <td></td> </tr> <tr> <td>4105</td> <td>✓</td> <td>✓</td> <td>✓</td> <td>✓</td> <td>Yes The critical mode alarm classes will override the normal operation alarm classes when in MANUAL operation mode and the <i>LogicsManager</i> output 12220 becomes TRUE. No The alarm classes will not be changed in the MANUAL operating mode.</td> <td></td> </tr> </table>	EN		Override alarmcl. also in MAN				Critical mode alarm classes active in MANUAL operating mode	Yes / No	DE		Sprinkler Alarmkl. in MAN						CL2	{0}	{1o}	{1oc}	{2oc}			4105	✓	✓	✓	✓	Yes The critical mode alarm classes will override the normal operation alarm classes when in MANUAL operation mode and the <i>LogicsManager</i> output 12220 becomes TRUE. No The alarm classes will not be changed in the MANUAL operating mode.								
EN		Override alarmcl. also in MAN				Critical mode alarm classes active in MANUAL operating mode	Yes / No																														
DE		Sprinkler Alarmkl. in MAN																																			
CL2	{0}	{1o}	{1oc}	{2oc}																																	
4105	✓	✓	✓	✓	Yes The critical mode alarm classes will override the normal operation alarm classes when in MANUAL operation mode and the <i>LogicsManager</i> output 12220 becomes TRUE. No The alarm classes will not be changed in the MANUAL operating mode.																																

Configure Application: Configure Controller



WARNING

The following parameters dictate how the easYgen-2000 Series controls voltage, frequency, load, and power factor. It is vital that the correct setting be entered in these parameters. Failure to do so may lead to incorrect measurements and failures within the control unit resulting in damage to or destruction of the generator and/or personal injury or death.

Overview

The Real load, reactive load, and process control all utilize PID controllers. The response of each control loop can be adjusted for optimum response, however it is important to understand what a PID controller is and the effect of each controller adjustment has on the controller response. Proportional gain, integral gain (stability), and DR (speed derivative ratio) are the adjustable and interacting parameters used to match the response of the control loop with the response of the system. They correspond to the P (proportional), I (integral), and D (derivative) terms, and are displayed in the easYgen as follows:

- P = Proportional gain (%)
- I = Integral gain (%)
- D = Derivative gain (determined by DR and I)

Proportional Control

Proportional response is directly proportional to a process change. [Analogy: Setting hand throttle to keep constant speed on straight and level.]

Proportional control (using the same analogy) results in a certain speed as long as the car is not subjected to any load change such as a hill. If a throttle is set to any particular setting, the speed of the car will remain constant as long as the car remains straight and level. If the car goes up a hill it will slow down. Of course, going down a hill the car would gain speed.

Integral Control

Integral compensates for process and set point load changes. [Analogy: Cruise control maintains constant speed regardless of hills.]

Integral, sometimes called reset, provides additional action to the original proportional response as long as the process variable remains away from the set point. Integral is a function of the magnitude and duration of the deviation. In this analogy the reset response would keep the car speed constant regardless of the terrain.

Derivative

Derivative provides a temporary over-correction to compensate for long transfer lags and reduce stabilization time on process upsets (momentary disturbances). The behavior of the derivative parameter is shown in Figure 3-28 on page 218. [Analogy: Accelerating into high speed lane with merging traffic.]

Derivative, sometimes called "preact" or "rate", is very difficult to draw an accurate analogy to, because the action takes place only when the process changes and is directly related to the speed at which the process changes. Merging into high speed traffic of a freeway from an "on" ramp is no easy task and requires accelerated correction (temporary overcorrection) in both increasing and decreasing directions. The application of brakes to fall behind the car in the first continuous lane or passing gear to get ahead of the car in the first continuous lane is a derivative action.

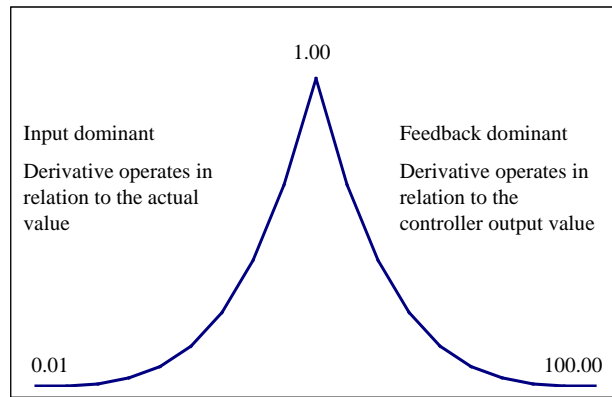

Figure 3-28: Controllers - Behavior of the derivative parameter

PID Tuning Example

If the system is unstable, make sure the governor is the cause. This can be checked by closing the valve limiter until it has control of the actuator output. If the governor is causing the oscillation, time the oscillation cycle time. A rule-of-thumb is, if the system's oscillation cycle time is less than 1 second, reduce the Proportional gain term. A rule-of-thumb is, if the system's oscillation cycle time is greater than 1 second, reduce the Integral gain term (proportional gain may need to be increased also).

On an initial startup with the easYgen-2000 Series, all PID dynamic gain terms will require adjustment to match the respective PID's response to that of its control loop. There are multiple dynamic tuning methods available that can be used with the easYgen's PIDs to assist in determining the gain terms that provide optimum control loop response times.

The following method can be used to achieve PID gain values that are close to optimum:

1. Increase Derivative Ratio (DR) to 100.
2. Reduce integral gain to 0.01.
3. Increase proportional gain until system just starts to oscillate.
4. The optimum gain for this step is when the system just starts to oscillate and maintains a self-sustaining oscillation that does not increase or decrease in magnitude.
5. Record the control gain (K_c) and oscillation period (T) in seconds.
6. Set the dynamics as follows:
 - For PI control: $G=P(I/s + 1)$
 - Set: Proportional gain = $0.45*K_c$
 - Integral gain = $1.2/T$
 - Derivative ratio = 100
 - For PID control: $G=P(I/s + 1 + Ds)$
 - Set: Proportional gain = $0.60*K_c$
 - Integral gain = $2/T$
 - Deriv ratio = $8/(T*Integral\ Gain)$ for feedback dominant
 = $(T*Integral\ Gain)/8$ for input dominant
7. This method of tuning will get the gain settings close, they can be fine-tuned from this point.

Configure Application: Controller, Frequency Control

Parameter table

Level	Text	Setting range	Default value
Configure frequency control			
	Frequency control	Off / PID analog / 3pos controller	PID analog
	Proportional gain	0.01 to 100.00	1.00
	Integral gain	0.01 to 100.00	1.00
	Derivative ratio	0.01 to 100.00	0.01
	Deadband	0.02 to 9.99 Hz	0.08 Hz
	Time pulse minimum	0.01 to 2.00 s	0.05 s
	Gain factor	0.1 to 10.0	5.0
	Expand deadband factor	1.0 to 9.9	1.0
	Delay expand deadband	1.0 to 9.9 s	2.0 s
	Frequency setpoint 1 source	Analogmanager	05.01
	Int. freq. control setpoint 1	15.00 to 85.00 Hz	50.00 Hz
	Frequency setpoint 2 source	Analogmanager	05.02
	Int. freq. control setpoint 2	15.00 to 85.00 Hz	50.00 Hz
	Setpoint 2 freq.	LogicsManager	(0 & 1) & 1
	Start frequency control level	15.00 to 85.00 Hz	47.00 Hz
	Start frequency control delay	0 to 999 s	5 s
	Freq. control setpoint ramp	0.10 to 60.00 Hz/s	2.50 Hz/s
	Frequency control droop	0.0 to 20.0 %	2.0 %
	Freq. droop act.	LogicsManager	(08.17 & 1) & 1
	Slip frequency setpoint offset	0.00 to 0.50 Hz	0.10 Hz
	Phase matching gain	1 to 99	5
	Phase matching df-start	0.02 to 0.25 Hz	0.05 Hz
	Freq. control initial state	0.0 to 100.0 %	50.0 %

Table 3-100: Application - standard values - configure frequency control

EN	Frequency Control				
DE	Frequenzregler				
CL2	{0}	{1o}	{1oc}	{2oc}	
5507	✓	✓	✓	✓	

Frequency control: activation

PID analog / 3pos controller / Off

PID analog .. The frequency is controlled using an analog PID controller.
3pos contr.... The frequency is controlled using a three-step controller.
Off..... The frequency control is not carried out.

EN	Proportional gain				
DE	Verstärkung				
CL2	{0}	{1o}	{1oc}	{2oc}	
5510	✓	✓	✓	✓	

Frequency control: proportional gain

0.01 to 100.00

ⓘ This parameter is only visible if frequency control (parameter 5507) is configured to "PID analog".

The proportional coefficient specifies the gain. By increasing the gain, the response is increased to permit larger corrections to the variable to be controlled. The farther out of tolerance the process is the larger the response action is to return the process to the tolerance band. If the gain is configured too high, the result is excessive overshoot/undershoot of the desired value.

EN	Integral gain				
DE	Integrierbeiwert				
CL2	{0}	{1o}	{1oc}	{2oc}	
5511	✓	✓	✓	✓	

Frequency control: integral gain

0.01 to 100.00

ⓘ This parameter is only visible if frequency control (parameter 5507) is configured to "PID analog".

The integral gain identifies the I part of the PID controller. The integral gain corrects for any offset (between set point and process variable) automatically over time by shifting the proportioning band. Reset automatically changes the output requirements until the process variable and the set point are the same. This parameter permits the user to adjust how quickly the reset attempts to correct for any offset. The integral gain constant must be greater than the derivative time constant. If the integral gain constant is too large, the engine will continually oscillate. If the integral gain constant is too small, the engine will take too long to settle at a steady state.

		Derivative ratio			
		Differenziervhältnis			
EN	CL2	{0}	{1o}	{1oc}	{2oc}
DE	5512	✓	✓	✓	✓

Frequency control: derivative ratio 0.01 to 100.00

ⓘ This parameter is only visible if frequency control (parameter 5507) is configured to "PID analog".

The derivative ratio identifies the D part of the PID controller. By increasing this parameter, the stability of the system is increased. The controller will attempt to slow down the action of the actuator in an attempt to prevent excessive overshoot or undershoot. Essentially this is the brake for the process. This portion of the PID loop operates anywhere within the range of the process unlike reset.

		Deadband			
		Unempfindlichkeit			
EN	CL1	{0}	{1o}	{1oc}	{2oc}
DE	5550	✓	✓	✓	✓

Frequency control: deadband 0.02 to 9.99 Hz

ⓘ This parameter is only visible if frequency control (parameter 5507) is configured to "3pos controller".

Isolated operation: The generator frequency is controlled in such a manner that the measured frequency does not deviate from the configured set point by more than the value configured in this parameter without the controller issuing a frequency raise/lower signal to the frequency control. This prevents unneeded wear on the frequency bias output control or the raise/lower relay contacts.

Example: If the frequency set point is 50 Hz and a deadband of 0.5 Hz is configured, the measured generator frequency must exceed 50.5 Hz (50 + 0.5) to issue a lower pulse or fall below 49.5 Hz (50 - 0.5) to issue a raise pulse.

Synchronization: The generator frequency is controlled in such a manner that the measured frequency does not deviate from the monitored reference (mains or busbar) frequency by more than the value configured in this parameter without the controller issuing a frequency raise/lower signal to the frequency control. This prevents unneeded wear on the frequency bias output control or the raise/lower relay contacts. The value configured for this parameter must be less than the value configured for the df max (maximum frequency differential) for synchronization.

		Time pulse minimum			
		Impulsdauer Minimum			
EN	CL1	{0}	{1o}	{1oc}	{2oc}
DE	5551	✓	✓	✓	✓

Frequency control: time pulse minimum 0.01 to 2.00 s

ⓘ This parameter is only visible if frequency control (parameter 5507) is configured to "3pos controller".

A minimum pulse on time must be configured here. The shortest possible pulse time should be configured to limit overshoot of the desired speed reference point.

		Gain factor			
		Verstärkungsfaktor			
EN	CL1	{0}	{1o}	{1oc}	{2oc}
DE	5552	✓	✓	✓	✓

Frequency control: gain factor 0.1 to 10.0

ⓘ This parameter is only visible if frequency control (parameter 5507) is configured to "3pos controller".

The gain factor Kp influences the operating time of the relays. By increasing the number configured in this parameter, the operating time of the relay will be increased in response to a deviation from the frequency reference. By increasing the gain, the response is increased to permit larger corrections to the variable to be controlled. The farther out of tolerance the process is the larger the response action is to return the process to the tolerance band. If the gain is configured too high, the result is excessive overshoot/undershoot of the desired value.

EN	Expand deadband factor				Frequency control: expand deadband factor	1.0 to 9.9
DE	Aufweitung Unempfindlichkeit					
CL1 5553	{0}	{10}	{10c}	{20c}	<p>① This parameter is only visible if frequency control (parameter 5507) is configured to "3pos controller".</p>	
	✓	✓	✓	✓		

If the measured generator frequency is within the deadband range (parameter 5550) and the configured delay expand deadband time (parameter 5554) expires, the deadband will be multiplied with the factor configured here.

Kick Impulse Function

Frequency control provides a kick impulse function, which issues a pulse if the frequency control deadband (parameter 5550) is not exceeded and no synchronization could be performed for 20 seconds. The function is enabled, if a synchronization is carried out.

If the phase angle is between 0° and 180°, a "frequency lower" signal is issued.

If the phase angle is between 180° and 360°, a "frequency raise" signal is issued.

The pulse duration is 100ms. If the synchronization still fails, another pulse will be issued after 10 seconds.



The following conditions are required for the kick impulse function:

- Frequency control (parameter 5507) is configured to "3pos controller"
- Synchronization mode (parameter 5728) is configured to "RUN" or "CHECK" (or "Controlled by LM" and RUN or CHECK enabled by the *LogicsManager*)

EN	Delay expand deadband				Frequency control: delay expand deadband	1.0 to 9.9 s
DE	Verzögerung Aufweitung					
CL1 5554	{0}	{10}	{10c}	{20c}	<p>① This parameter is only visible if frequency control (parameter 5507) is configured to "3pos controller".</p>	
	✓	✓	✓	✓		

The measured generator frequency must be within the deadband range for the time configured here in order to multiply the deadband with the factor configured in parameter 5553.

EN	Frequency setpoint 1 source				Frequency control: frequency setpoint 1 source	refer to text below
DE	Frequenz Sollwert 1 Auswahl					
CL2 5518	{0}	{10}	{10c}	{20c}		
	✓	✓	✓	✓		

The Frequency setpoint 1 source may be selected from the available data sources. Use the  and  softkeys to scroll through the list of variables and confirm your selection with the  softkey. Even it is possible to select all data sources (refer to Appendix C on page 307), only the following data sources may be used (selecting a different data source may not allow the controller to operate properly):

- 05.01 Internal frequency setpoint 1
Internal frequency control setpoint 1 (parameter 5500) is used as setpoint 1
- 05.02 Internal frequency setpoint 2
Internal frequency control setpoint 2 (parameter 5501) is used as setpoint 1
- 05.03 Interface frequency setpoint
The setpoint, which is transmitted via the interface, is used as setpoint
- 05.13 Discrete raise/lower frequency
The setpoint from the discrete raise/lower frequency function is used as setpoint
- 06.01 Analog input 1
Analog input 1 is used to control the setpoint
- 06.02 Analog input 2
Analog input 2 is used to control the setpoint
- 06.03 Analog input 3
Analog input 3 is used to control the setpoint

The frequency set point may be adjusted within the configured operating limits (refer to Configure Monitoring: Generator, Operating Voltage / Frequency on page 50).

EN	Int. freq. control setpoint 1			
DE	Frequenzregler Sollwert 1 int.			
CL1	{0}	{1o}	{1oc}	{2oc}
5500	✓	✓	✓	✓

Frequency control: internal set point 1 **15.00 to 85.00 Hz**

The internal generator frequency set point 1 is defined in this screen. This value is the reference for the frequency controller when performing isolated and/or no-load operations. Generally 50 Hz or 60 Hz will be the values entered into this parameter. It is possible to enter a different value here.

EN	Frequency setpoint 2 source			
DE	Frequenz Sollwert 2 Auswahl			
CL2	{0}	{1o}	{1oc}	{2oc}
5519	✓	✓	✓	✓

Frequency control: frequency setpoint 2 source **refer to text below**

The Frequency setpoint 2 source may be selected from the available data sources. Use the **←** and **→** softkeys to scroll through the list of variables and confirm your selection with the **OK** softkey. Even it is possible to select all data sources (refer to Appendix C on page 307), only the following data sources may be used (selecting a different data source may not allow the controller to operate properly):

- 05.01 Internal frequency setpoint 1
Internal frequency control setpoint 1 (parameter 5500) is used as setpoint 2
- 05.02 Internal frequency setpoint 2
Internal frequency control setpoint 2 (parameter 5501) is used as setpoint 2
- 05.03 Interface frequency setpoint
The setpoint, which is transmitted via the interface, is used as setpoint
- 05.13 Discrete raise/lower frequency
The setpoint from the discrete raise/lower frequency function is used as setpoint
- 06.01 Analog input 1
Analog input 1 is used to control the setpoint
- 06.02 Analog input 2
Analog input 2 is used to control the setpoint
- 06.03 Analog input 3
Analog input 3 is used to control the setpoint

The frequency set point may be adjusted within the operating limits (refer to Configure Monitoring: Generator, Operating Voltage / Frequency on page 50).

EN	Int. freq. control setpoint 2			
DE	Frequenzregler Sollwert 2 int.			
CL1	{0}	{1o}	{1oc}	{2oc}
5501	✓	✓	✓	✓

Frequency control: internal set point 2 **15.00 to 85.00 Hz**

The internal generator frequency set point 2 is defined in this screen. This value is the reference for the frequency controller when performing isolated and/or no-load operations. Generally 50 Hz or 60 Hz will be the values entered into this parameter. It is possible that a different value may be entered here.

EN	Setpoint 2 freq.			
DE	Freq. Sollwert 2			
CL2	{0}	{1o}	{1oc}	{2oc}
12918	✓	✓	✓	✓

Frequency control: frequency set point 2 activation **LogicsManager**

If this *LogicsManager* condition is TRUE, the frequency set point 2 will be enabled, i.e. the setting of parameter 5519 overrides the setting of parameter 5518. The *LogicsManager* and its default settings are explained on page 273 in Appendix B: "*LogicsManager*".

EN	Start frequency control level			
DE	Startwert			
CL1	{0}	{1o}	{1oc}	{2oc}
5516	✓	✓	✓	✓

Frequency control: start value **15.00 to 85.00 Hz**

The frequency controller is activated when the monitored generator frequency has exceeded the value configured in this parameter. This prevents the easYgen from attempting to control the frequency while the engine is completing its start sequence.

EN	Start frequency control delay				Frequency control: start delay	0 to 999 s
DE	Start Verzögerung					
CL1	{0}	{10}	{10c}	{20c}	The frequency controller is enabled after the configured time for this parameter expires.	
5517	✓	✓	✓	✓		
EN	Freq. control set point ramp				Frequency control: set point ramp	0.10 to 60.00 Hz/s
DE	Frequenzregler Rampe					
CL2	{0}	{10}	{10c}	{20c}	The different set point values are supplied to the controller via this ramp. The slope of the ramp is used to alter the rate at which the controller modifies the set point value. The faster the change in the set point is to be carried out, the greater the value entered here must be.	
5503	✓	✓	✓	✓		
EN	Frequency control droop				Frequency control: droop	0.1 to 20.0 %
DE	Frequenzregler Statik					
CL2	{0}	{10}	{10c}	{20c}	If this control is to be operated on a generator in parallel with other generators and frequency control is enabled, a droop characteristic curve must be used. Each generator in the system will require the same value to be configured for the droop characteristic, so that when the system is stable the active power will be distributed proportionally among all generators in relation to their rated power.	
5504	✓	✓	✓	✓		
EN	Freq. droop act.				Frequency droop active	LogicsManager
DE	Freq.Statik akt.					
CL2	{0}	{10}	{10c}	{20c}	If this <i>LogicsManager</i> condition is TRUE, the frequency droop is enabled. The <i>LogicsManager</i> and its default settings are explained on page 273 in Appendix B: " <i>LogicsManager</i> ".	
12904	✓	✓	✓	✓		



NOTE

The active droop will also be sent to an ECU connected to the J1939 interface (CAN interface 2). This information is independent from the breaker states or active controller (frequency or power controller).

Example

Rated power: 500 kW
 Rated frequency set point: 50.0 Hz
 Droop 5.0 %

Active power 0 kW = 0 % of rated power
 Frequency is adjusted to $(50.0 \text{ Hz} - [5.0\% * 0.0 * 50 \text{ Hz}]) = 50.0 \text{ Hz}$.

Active power +250 kW = +50 % of rated power
 Frequency is adjusted to $(50.0 \text{ Hz} - [5\% * 0.50 * 50 \text{ Hz}]) = 50.0 \text{ Hz} - 1.25 \text{ Hz} = 48.75 \text{ Hz}$.

Active power +500 kW = +100 % of rated power
 Frequency is adjusted to $(50.0 \text{ Hz} - [5\% * 1.00 * 50 \text{ Hz}]) = 50.0 \text{ Hz} - 2.5 \text{ Hz} = 47.50 \text{ Hz}$.

EN	Slip frequency setpoint offset				Frequency control: slip frequency set point offset	0.00 to 0.50 Hz
DE	Frequenz Offset Schlupf					
CL2	{0}	{10}	{10c}	{20c}	This value is the offset for the synchronization to the busbar / utility. With this offset, the unit synchronizes with a positive slip.	
5502	✓	✓	✓	✓		
					Example:	
					If this parameter is configured to 0.10 Hz and the busbar/mains frequency is 50.00 Hz, the synchronization set point is 50.10 Hz.	
EN	Phase matching gain				Frequency control: phase matching gain	1 to 99
DE	Nullphasen Regelg. Verstärkg.					
CL2	{0}	{10}	{10c}	{20c}	The phase matching gain multiplies the setting of the proportional gain (parameter 5510 on page 219) for phase matching control.	
5505	✓	✓	✓	✓		

EN	Phase matching df-start			
DE	Nullphasen Regelg. df-Start			
CL2	{0}	{1o}	{1oc}	{2oc}
5506	✓	✓	✓	✓

Frequency control: phase matching df start **0.02 to 0.25 Hz**

Phase matching will only be enabled if the frequency difference between the systems to be synchronized is below the configured value.

EN	Freq. control initial state			
DE	Frequenzregler Grundstellung			
CL2	{0}	{1o}	{1oc}	{2oc}
5508	✓	✓	✓	✓

Frequency control: initial state **0.0 to 100.0 %**

The value entered for this parameter is the start reference point for the analog output to the speed controller. If the output to the speed control has been disabled, the output will act as a control position reference point.

Configure Application: Controller, Load Control

Parameter table

Level	Text	Setting range	Default value
Configure load control			
	Load control	Off / PID analog / 3pos controller	PID analog
	Proportional gain	0.01 to 100.00	1.00
	Integral gain	0.01 to 100.00	1.00
	Derivative ratio	0.01 to 100.00	0.01
	Deadband	0.10 to 9.99 %	1.00 %
	Time pulse minimum	0.01 to 2.00 s	0.05 s
	Gain factor	0.1 to 10.0	5.0
	Expand deadband factor	1.0 to 9.9	1.0
	Delay expand deadband	1.0 to 9.9 s	2.0 s
	Load setpoint 1 source	<i>Analogmanager</i>	05.04
	Load setpoint 1	Constant / Import / Export	Constant
	Int. load control setpoint 1	0.0 to 99999.9 kW	100.0 kW
	Load setpoint 2 source	<i>Analogmanager</i>	05.05
	Load setpoint 2	Constant / Import / Export	Constant
	Int. load control setpoint 2	0.0 to 99999.9 kW	200.0 kW
	Setpoint 2 load	<i>LogicsManager</i>	(0 & 1) & 1
	Load control setpoint ramp	0.10 to 100.00 %/s	3.00 %/s
	Load control setpoint maximum	0 to 150 %	100 %
	Minimum gen. import/export	0 to 100 %	0 %
	Warm up load limit	0 to 100 %	15 %
	Warm up time	0 to 9999 s	0 s
	Warm up mode	Time controlled / Analog val contr	Time controlled
	Engine warmup criterion	<i>Analogmanager</i>	06.01
	Warm up threshold	0 to 1000 °C	80 °C

Table 3-101: Application - standard values - configure load control

EN	Load Control				
DE	Wirkleistungsregler				
CL2	{0}	{1o}	{1oc}	{2oc}	
5525	✓	✓	✓	✓	

Load control: activation

PID analog / 3pos controller / Off

PID analog...The generator load is controlled using an analog PID controller.
3pos contr.The generator load is controlled using a three-step controller.
OffLoad control is not carried out.

EN	Proportional gain				
DE	Verstärkung				
CL2	{0}	{1o}	{1oc}	{2oc}	
5513	✓	✓	✓	✓	

Load control: proportional gain

0.01 to 100.00

① This parameter is only visible if load control (parameter 5525) is configured to "PID analog".

The proportional coefficient specifies the gain. By increasing the gain, the response is increased to permit larger corrections to the variable to be controlled. The farther out of tolerance the process is the larger the response action is to return the process to the tolerance band. If the gain is configured too high, the result is excessive overshoot/undershoot of the desired value.

EN	Integral gain				
DE	Integrierbeiwert				
CL2	{0}	{1o}	{1oc}	{2oc}	
5514	✓	✓	✓	✓	

Load control: integral gain

0.01 to 100.00

① This parameter is only visible if load control (parameter 5525) is configured to "PID analog".

The integral gain identifies the I part of the PID controller. The integral gain corrects for any offset (between set point and process variable) automatically over time by shifting the proportioning band. Reset automatically changes the output requirements until the process variable and the set point are the same. This parameter permits the user to adjust how quickly the reset attempts to correct for any offset. The integral gain constant must be greater than the derivative time constant. If the integral gain constant is too large, the engine will continually oscillate. If the integral gain constant is too small, the engine will take too long to settle at a steady state.

EN	Derivative ratio			
DE	Differenzverhältnis			
CL2 5515	{0}	{1o}	{1oc}	{2oc}
	✓	✓	✓	✓

Load control: derivative ratio **0.01 to 100.00**

ⓘ This parameter is only visible if load control (parameter 5525) is configured to "PID analog".

The derivative ratio identifies the D part of the PID controller. By increasing this parameter, the stability of the system is increased. The controller will attempt to slow down the action of the actuator in an attempt to prevent excessive overshoot or undershoot. Essentially this is the brake for the process. This portion of the PID loop operates anywhere within the range of the process unlike reset.

EN	Deadband			
DE	Unempfindlichkeit			
CL1 5560	{0}	{1o}	{1oc}	{2oc}
	✓	✓	✓	✓

Load control: deadband **0.10 to 9.99 %**

ⓘ This parameter is only visible if load control (parameter 5525) is configured to "3pos controller".

The generator load is controlled in such a manner, when paralleled with the mains, so that the monitored load does not deviate from the configured load set point by more than the value configured in this parameter without the controller issuing a raise/lower signal to the speed control. This prevents unneeded wear on the raise/lower relay contacts. The configured percentage for the dead band refers to the generator rated active power (parameter 1752 on page 40).

EN	Time pulse minimum			
DE	Impulsdauer Minimum			
CL1 5561	{0}	{1o}	{1oc}	{2oc}
	✓	✓	✓	✓

Load control: time pulse minimum **0.01 to 2.00 s**

ⓘ This parameter is only visible if load control (parameter 5525) is configured to "3pos controller".

A minimum pulse on time must be configured here. The shortest possible pulse time should be configured to limit overshoot of the desired load reference point.

EN	Gain factor			
DE	Verstärkungsfaktor			
CL1 5562	{0}	{1o}	{1oc}	{2oc}
	✓	✓	✓	✓

Load control: gain factor **0.1 to 10.0**

ⓘ This parameter is only visible if load control (parameter 5525) is configured to "3pos controller".

The gain factor Kp influences the operating time of the relays. By increasing the number configured in this parameter, the operating time of the relay will be increased in response to a deviation from the power reference. By increasing the gain, the response is increased to permit larger corrections to the variable to be controlled. The farther out of tolerance the process is the larger the response action is to return the process to the tolerance band. If the gain is configured too high, the result is excessive overshoot/undershoot of the desired value.

EN	Expand deadband factor			
DE	Aufweitung Unempfindlichkeit			
CL1 5563	{0}	{1o}	{1oc}	{2oc}
	✓	✓	✓	✓

Load control: expand deadband factor **1.0 to 9.9**

ⓘ This parameter is only visible if load control (parameter 5525) is configured to "3pos controller".

If the measured generator load is within the deadband range (parameter 5560) and the configured delay expand deadband time (parameter 5564) expires, the deadband will be multiplied with the factor configured here.

EN	Delay expand deadband			
DE	Verzögerung Aufweitung			
CL1 5564	{0}	{1o}	{1oc}	{2oc}
	✓	✓	✓	✓



Load control: delay expand deadband 1.0 to 9.9 s

ⓘ This parameter is only visible if load control (parameter 5525) is configured to "3pos controller".

The measured generator load must be within the deadband range for the time configured here in order to multiply the deadband with the factor configured in parameter 5563.

EN	Load setpoint 1 source			
DE	Wirkl. Sollwert 1 Auswahl			
CL2 5539	{0}	{1o}	{1oc}	{2oc}
	✓	✓	✓	✓

Load control: load setpoint 1 source refer to text below

The load setpoint 1 source may be selected from the available data sources. Use the  and  softkeys to scroll through the list of variables and confirm your selection with the  softkey. Even it is possible to select all data sources (refer to Appendix C on page 307), only the following data sources may be used (selecting a different data source may not allow the controller to operate properly):

- 05.04 Internal load setpoint 1
Internal load control setpoint 1 (parameter 5520) is used as setpoint 1
- 05.05 Internal load setpoint 2
Internal load control setpoint 2 (parameter 5527) is used as setpoint 1
- 05.06 Interface load setpoint
The setpoint, which is transmitted via the interface, is used as setpoint
- 05.14 Discrete raise/lower load
The setpoint from the discrete raise/lower load function is used as setpoint
- 06.01 Analog input 1
Analog input 1 is used to control the setpoint
- 06.02 Analog input 2
Analog input 2 is used to control the setpoint
- 06.03 Analog input 3
Analog input 3 is used to control the setpoint

The load set point may be adjusted between 0 and the configured load control setpoint maximum (parameter 5523 on page 229).

EN	Load setpoint 1			
DE	Sollwert 1			
CL2 5526	{0}	{1o}	{1oc}	{2oc}
	✓	✓	✓	✓

Load control: set point 1 Import / Export / Constant

Import The value entered for the import level shall always be supplied by the utility. All load swings are absorbed by the generator(s) provided the load rating for the generator(s) is not exceeded. The generator will always start when an import power operation is enabled.

Export..... The value entered for the export level shall always be supplied to the utility. All load swings are absorbed by the generator(s) provided the load rating for the generator(s) is not exceeded. The generator will always start when an export power operation is enabled.

Constant The generator shall always supply the value entered for the constant power level. All load swings are absorbed by the utility. The generator will always start when a constant power (base load) operation is enabled.

EN	Int. load control setpoint 1			
DE	Lstg.regler Sollwert 1 intern			
CL1 5520	{0}	{1o}	{1oc}	{2oc}
	✓	✓	✓	✓

Load control: internal load control set point 1 0 to 9,999.9 kW

The load set point 1 is defined in this screen. This value is the reference for the load controller when performing parallel operations.

		Load setpoint 2 source			
		Wirkl. Sollwert 2 Auswahl			
EN	CL2	{0}	{1o}	{1oc}	{2oc}
DE	5540	✓	✓	✓	✓

Load control: load setpoint 2 source

refer to text below

The load setpoint 2 source may be selected from the available data sources. Use the and softkeys to scroll through the list of variables and confirm your selection with the softkey. Even it is possible to select all data sources (refer to Appendix C on page 307), only the following data sources may be used (selecting a different data source may not allow the controller to operate properly):

- 05.04 Internal load setpoint 1
Internal load control setpoint 1 (parameter 5520) is used as setpoint 2
- 05.05 Internal load setpoint 2
Internal load control setpoint 2 (parameter 5527) is used as setpoint 2
- 05.06 Interface load setpoint
The setpoint, which is transmitted via the interface, is used as setpoint
- 05.14 Discrete raise/lower load
The setpoint from the discrete raise/lower load function is used as setpoint
- 06.01 Analog input 1
Analog input 1 is used to control the setpoint
- 06.02 Analog input 2
Analog input 2 is used to control the setpoint
- 06.03 Analog input 3
Analog input 3 is used to control the setpoint

The load set point may be adjusted between 0 and the configured load control setpoint maximum (parameter 5523 on page 229).

		Load setpoint 2			
		Sollwert 2			
EN	CL2	{0}	{1o}	{1oc}	{2oc}
DE	5527	✓	✓	✓	✓

Load control: set point 2

Import / Export / Constant

ImportThe value entered for the import level shall always be supplied by the utility. All load swings are absorbed by the generator(s) provided the load rating for the generator(s) is not exceeded. The generator will always start when an import power operation is enabled.

ExportThe value entered for the export level shall always be supplied to the utility. All load swings are absorbed by the generator(s) provided the load rating for the generator(s) is not exceeded. The generator will always start when an export power operation is enabled.

Constant.....The generator shall always supply the value entered for the constant power level. All load swings are absorbed by the utility. The generator will always start when a constant power (base load) operation is enabled.

		Int. load control setpoint 2			
		Lstg.regler Sollwert 2 intern			
EN	CL1	{0}	{1o}	{1oc}	{2oc}
DE	5521	✓	✓	✓	✓

Load control: internal load control set point 2

0 to 9,999.9 kW

The load set point 2 is defined in this screen. This value is the reference for the load controller when performing parallel operations.

		Setp. 2 load			
		Lstg.regler Soll2			
EN	CL2	{0}	{1o}	{1oc}	{2oc}
DE	12919	✓	✓	✓	✓

Load control: set point 2 request

LogicsManager

If this *LogicsManager* condition is TRUE, the load set point 2 will be enabled, i.e. the setting of parameter 5540 overrides the setting of parameter 5539. The *LogicsManager* and its default settings are explained on page 273 in Appendix B: "*LogicsManager*".

EN	Load control setpoint ramp			
DE	Leistungsregler Rampe			
CL2	{0}	{1o}	{1oc}	{2oc}
5522	✓	✓	✓	✓

Load control: set point ramp **0.10 to 100.0 %/s**

The different set point values are supplied to the controller via this ramp. The slope of the ramp is used to alter the rate at which the controller modifies the set point value. The faster the change in the set point is to be carried out, the greater the value entered here must be.

Note: This ramp is also used in isolated operation for loading or unloading an additional genset. An excessive oscillation may occur if the ramp is configured too high.

EN	Load control setpoint maximum			
DE	Leistungsregler Sollwert Maximum			
CL2	{0}	{1o}	{1oc}	{2oc}
5523	✓	✓	✓	✓

Load control: set point maximum **0 to 150 %**

If the maximum generator load is to be limited, a percentage based on the rated generator power (parameter 1752 on page 40) must be entered here. The controller adjusts the generator in such a manner that this value is not exceeded. This parameter limits the set point of the load controller when the generator is in a mains parallel operation.

EN	Minimum gen. import/export			
DE	Min. Gen.leistg Übergabereg.			
CL2	{0}	{1o}	{1oc}	{2oc}
5524	✓	✓	✓	✓

Load control: minimum generator load on import/export **0 to 100 %**

If the minimum generator load is to be limited, a percentage based on the rated generator power (parameter 1752 on page 40) must be entered here. The controller will not permit the load to drop below the configured load limit value. This parameter is only functional when the generator is in a mains parallel operation.

EN	Warm up load limit			
DE	Aufwärmleistungs-Limit			
CL2	{0}	{1o}	{1oc}	{2oc}
5532	✓	✓	✓	✓

Load control: warm up load limit **0 to 100 %**

The maximum load is limited to this percentage of the generator rated power (parameter 1752 on page 40) until the warm up time (parameter 5534 on page 229) has expired or the warm up temperature threshold (parameter 5546 on page 230) has been exceeded.

EN	Warm up time			
DE	Aufwärmzeit			
CL2	{0}	{1o}	{1oc}	{2oc}
5534	✓	✓	✓	✓

Power control: warm up time **0 to 9999 s**

ⓘ This parameter is only effective if Warm up mode (parameter 5533) is configured to "Time controlled".

The maximum load is limited to the value configured in parameter 5532 on page 229 for the time configured here.

EN	Warm up mode			
DE	Aufwärmmodus			
CL2	{0}	{1o}	{1oc}	{2oc}
5533	✓	✓	✓	✓

Load control: warm up mode **Analog val contr / Time controlled**

Analog val contr.. The maximum load is limited to the value configured in parameter 5532 until the temperature measured according to the setting in parameter 5538 has exceeded the threshold configured in parameter 5546.

Time controlled... The maximum load is limited to the value configured in parameter 5532 until the time configured in parameter 5534 has expired.

EN	Engine warm up criterium			
DE	Teillast Warmlauf Kriterium			
CL2	{0}	{1o}	{1oc}	{2oc}
5538	✓	✓	✓	✓

Load control: warm up load criterion refer to text below

ⓘ This parameter is only effective if Warm up mode (parameter 5533) is configured to "Analog val contr".

The engine warm up criterion may be selected from the available data sources. Use the and softkeys to scroll through the list of variables and confirm your selection with the softkey. Even it is possible to select all data sources (refer to Appendix C on page 307), only the following data source may be used (selecting a different data source may not allow the controller to operate properly):

- 06.01 Analog input 1
Analog input 1 is used to control the setpoint
- 06.02 Analog input 2
Analog input 2 is used to control the setpoint
- 06.03 Analog input 3
Analog input 3 is used to control the setpoint
- 06.04 Analog input 4
Analog input 4 is used to control the setpoint

EN	Warm up threshold			
DE	Aufwärm Grenzwert			
CL2	{0}	{1o}	{1oc}	{2oc}
5546	✓	✓	✓	✓

Load control: warm up threshold 0 to 1000 °C

ⓘ This parameter is only effective if Warm up mode (parameter 5533) is configured to "Analog val contr".

The maximum load is limited to the value configured in parameter 5532 until the temperature has exceeded the threshold configured here.

Configure Application: Controller, Voltage Control

Parameter table

Level	Text	Setting range	Default value
Configure voltage control			
	Voltage control	Off / PID analog / 3pos controller	PID analog
	Proportional gain	0.01 to 100.00	1.00
	Integral gain	0.01 to 100.00	1.00
	Derivative ratio	0.01 to 100.00	0.01
	Deadband	0.10 to 9.99 %	1.00 %
	Time pulse minimum	0.01 to 2.00 s	0.05 s
	Gain factor	0.1 to 10.0	5.0
	Expand deadband factor	1.0 to 9.9	1.0
	Delay expand deadband	1.0 to 9.9 s	2.0 s
	Voltage setpoint 1 source	Analogmanager	05.07
	Int. voltage control setpoint 1	50 to 650000 V	400 V
	Voltage setpoint 2 source	Analogmanager	05.08
	Int. voltage control setpoint 2	50 to 650000 V	400 V
	Setpoint 2 voltage	LogicsManager	(0 & 1) & 1
	Start value	0 to 100 %	70 %
	Start delay	0 to 999 s	5 s
	Voltage control setpoint ramp	1.00 to 300.00 %/s	5.00 %/s
	Voltage control droop	0.0 to 20.0 %	5.0 %
	Volt. droop act.	LogicsManager	(08.17 & 1) & 1
	Voltage control initial state	0.0 to 100.0 %	50.0 %

Table 3-102: Application - standard values - configure voltage control

EN	Voltage Control
DE	Spannungsregler
CL2	{0} {1o} {1oc} {2oc}
5607	✓ ✓ ✓ ✓

Voltage control: activation **PID analog / 3pos controller / Off**

PID analog .. The voltage is controlled using an analog PID controller.
3pos contr.... The voltage is controlled using a three-step controller.
Off..... Voltage control is not carried out.

EN	Proportional gain
DE	Verstärkung
CL2	{0} {1o} {1oc} {2oc}
5610	✓ ✓ ✓ ✓

Voltage control: proportional gain **0.01 to 100.00**

ⓘ This parameter is only visible if voltage control (parameter 5607) is configured to "PID analog".

The proportional coefficient specifies the gain. By increasing the gain, the response is increased to permit larger corrections to the variable to be controlled. The farther out of tolerance the process is the larger the response action is to return the process to the tolerance band. If the gain is configured too high, the result is excessive overshoot/undershoot of the desired value.

EN	Integral gain
DE	Integrierbeiwert
CL2	{0} {1o} {1oc} {2oc}
5611	✓ ✓ ✓ ✓

Voltage control: integral gain **0.01 to 100.00**

ⓘ This parameter is only visible if voltage control (parameter 5607) is configured to "PID analog".

The integral gain identifies the I part of the PID controller. The integral gain corrects for any offset (between set point and process variable) automatically over time by shifting the proportioning band. Reset automatically changes the output requirements until the process variable and the set point are the same. This parameter permits the user to adjust how quickly the reset attempts to correct for any offset. The integral gain constant must be greater than the derivative time constant. If the integral gain constant is too large, the engine will continually oscillate. If the integral gain constant is too small, the engine will take too long to settle at a steady state.

		Derivative ratio			
		Differenzierverhältnis			
EN	DE	{0}	{1o}	{1oc}	{2oc}
CL2	5612	✓	✓	✓	✓

Voltage control: derivative ratio **0.01 to 100.00**

ⓘ This parameter is only visible if voltage control (parameter 5607) is configured to "PID analog".

The derivative ratio identifies the D part of the PID controller. By increasing this parameter, the stability of the system is increased. The controller will attempt to slow down the action of the actuator in an attempt to prevent excessive overshoot or undershoot. Essentially this is the brake for the process. This portion of the PID loop operates anywhere within the range of the process unlike reset.

		Deadband			
		Unempfindlichkeit			
EN	DE	{0}	{1o}	{1oc}	{2oc}
CL1	5650	✓	✓	✓	✓

Voltage control: deadband **0.10 to 9.99 %**

ⓘ This parameter is only visible if voltage control (parameter 5607) is configured to "3pos controller".

Isolated operation: The generator voltage is controlled in such a manner that the measured voltage does not deviate from the configured set point by more than the value configured in this parameter without the controller issuing a voltage raise/lower signal to the voltage regulator. This prevents unneeded wear on the voltage bias output control or the raise/lower relay contacts.

Synchronization: The generator voltage is controlled in such a manner that the measured voltage does not deviate from the monitored reference (mains or busbar) voltage by more than the value configured in this parameter without the controller issuing a voltage raise/lower signal to the voltage regulator. This prevents unneeded wear on the voltage bias output control or the raise/lower relay contacts. The value configured for this parameter must be less than the value configured for the dV max (maximum voltage differential) for synchronization (parameters 5700 or 5710).

		Time pulse minimum			
		Impulsdauer Minimum			
EN	DE	{0}	{1o}	{1oc}	{2oc}
CL1	5651	✓	✓	✓	✓

Voltage control: time pulse minimum **0.01 to 2.00 s**

ⓘ This parameter is only visible if voltage control (parameter 5607) is configured to "3pos controller".

A minimum pulse on time must be configured here. The shortest possible pulse time should be configured to limit overshoot of the desired voltage reference point.

		Gain factor			
		Verstärkungsfaktor			
EN	DE	{0}	{1o}	{1oc}	{2oc}
CL1	5652	✓	✓	✓	✓

Voltage control: gain factor **0.1 to 10.0**

ⓘ This parameter is only visible if voltage control (parameter 5607) is configured to "3pos controller".



The gain factor Kp influences the operating time of the relays. By increasing the number configured in this parameter, the operating time of the relay will be increased in response to a deviation from the voltage reference. By increasing the gain, the response is increased to permit larger corrections to the variable to be controlled. The farther out of tolerance the process is the larger the response action is to return the process to the tolerance band. If the gain is configured too high, the result is excessive overshoot/undershoot of the desired value.

EN	Expand deadband factor				Voltage control: expand deadband factor	1.0 to 9.9
DE	Aufweitung Unempfindlichkeit					
CLI	{0}	{1o}	{1oc}	{2oc}	<p>① This parameter is only visible if voltage control (parameter 5607) is configured to "3pos controller".</p>	
5653	✓	✓	✓	✓		

If the measured generator voltage is within the deadband range (parameter 5650) and the configured delay expand deadband time (parameter 5654) expires, the deadband will be multiplied with the factor configured here.

EN	Delay expand deadband				Voltage control: delay expand deadband	1.0 to 9.9 s
DE	Verzögerung Aufweitung					
CLI	{0}	{1o}	{1oc}	{2oc}	<p>① This parameter is only visible if voltage control (parameter 5607) is configured to "3pos controller".</p>	
5654	✓	✓	✓	✓		

The measured generator voltage must be within the deadband range for the time configured here in order to multiply the deadband with the factor configured in parameter 5653.

EN	Voltage setpoint 1 source				Voltage control: voltage setpoint 1 source	refer to text below
DE	Spannungs Sollwert 1 Auswahl					
CLI	{0}	{1o}	{1oc}	{2oc}	<p>The voltage setpoint 1 source may be selected from the available data sources. Use the  and  softkeys to scroll through the list of variables and confirm your selection with the  softkey. Even it is possible to select all data sources (refer to Appendix C on page 307), only the following data sources may be used (selecting a different data source may not allow the controller to operate properly):</p> <ul style="list-style-type: none"> • 05.07 Internal voltage setpoint 1 Internal voltage control setpoint 1 (parameter 5600) is used as setpoint 1 • 05.08 Internal voltage setpoint 2 Internal voltage control setpoint 2 (parameter 5601) is used as setpoint 1 • 05.09 Interface voltage setpoint The setpoint, which is transmitted via the interface, is used as setpoint • 05.15 Discrete raise/lower voltage The setpoint from the discrete raise/lower voltage function is used as setpoint • 06.01 Analog input 1 Analog input 1 is used to control the setpoint • 06.02 Analog input 2 Analog input 2 is used to control the setpoint • 06.03 Analog input 3 Analog input 3 is used to control the setpoint • 06.04 Analog input 4 Analog input 4 is used to control the setpoint 	
5618	✓	✓	✓	✓		

The voltage set point may be adjusted within the configured operating limits (refer to Configure Monitoring: Generator, Operating Voltage / Frequency on page 50).

EN	Int.voltage control setpoint 1				Voltage control: internal voltage set point 1	50 to 650,000 V
DE	Spg.regler Sollwert 1 intern					
CLI	{0}	{1o}	{1oc}	{2oc}	<p>The internal generator voltage set point 1 is defined in this screen. This value is the reference for the voltage controller when performing isolated and/or no-load operations.</p>	
5600	✓	✓	✓	✓		

Voltage setpoint 2 source					
Spannungs Sollwert 2 Auswahl					
CL2	{0}	{1o}	{1oc}	{2oc}	
5619	✓	✓	✓	✓	

Voltage control: voltage setpoint 2 source refer to text below

The voltage setpoint 2 source may be selected from the available data sources. Use the **←** and **→** softkeys to scroll through the list of variables and confirm your selection with the **✓** softkey. Even it is possible to select all data sources (refer to Appendix C on page 307), only the following data sources may be used (selecting a different data source may not allow the controller to operate properly):

- 05.07 Internal voltage setpoint 1
Internal voltage control setpoint 1 (parameter 5600) is used as setpoint 2
- 05.08 Internal voltage setpoint 2
Internal voltage control setpoint 2 (parameter 5601) is used as setpoint 2
- 05.09 Interface voltage setpoint
The setpoint, which is transmitted via the interface, is used as setpoint
- 05.15 Discrete raise/lower voltage
The setpoint from the discrete raise/lower voltage function is used as setpoint
- 06.01 Analog input 1
Analog input 1 is used to control the setpoint
- 06.02 Analog input 2
Analog input 2 is used to control the setpoint
- 06.03 Analog input 3
Analog input 3 is used to control the setpoint
- 06.04 Analog input 4
Analog input 4 is used to control the setpoint

The voltage set point may be adjusted within the configured operating limits (refer to Configure Monitoring: Generator, Operating Voltage / Frequency on page 50).

Int.voltage control setpoint 2					
Spg.regler Sollwert 2 intern					
CL1	{0}	{1o}	{1oc}	{2oc}	
5601	✓	✓	✓	✓	

Voltage control: internal voltage set point 2 50 to 650,000 V

The internal generator voltage set point 2 is defined in this screen. This value is the reference for the voltage controller when performing isolated and/or no-load operations.

Setp. 2 voltage					
Spannung Einstellpunkt 2					
CL2	{0}	{1o}	{1oc}	{2oc}	
12920	✓	✓	✓	✓	

Voltage set point 2 request *LogicsManager*

If this *LogicsManager* condition is TRUE, the voltage set point 2 will be enabled, i.e. the setting of parameter 5619 overrides the setting of parameter 5618. The *LogicsManager* and its default settings are explained on page 273 in Appendix B: "*LogicsManager*".

Start value					
Startwert					
CL1	{0}	{1o}	{1oc}	{2oc}	
5616	✓	✓	✓	✓	

Voltage control: start value 0 to 100 %

ⓘ This value refers to the generator voltage set point (parameter 5600 or 5601 on page 234).

The voltage controller is activated when the monitored generator voltage has exceeded the value configured in this parameter. This prevents the easYgen from attempting to control the voltage while the engine is completing its start sequence.

Start delay					
Start Verzögerung					
CL1	{0}	{1o}	{1oc}	{2oc}	
5617	✓	✓	✓	✓	

Voltage control: start delay 0 to 999 s

The voltage controller is enabled after the configured time for this parameter expires.

EN	Voltage control set point ramp	Voltage control: set point ramp	1.00 to 300.00 %/s
DE	Spannungsregler Rampe		
CL2	{0} {1o} {1oc} {2oc}	The different set point values are supplied to the controller via this ramp. The slope of the ramp is used to alter the rate at which the controller modifies the set point value. The faster the change in the set point is to be carried out, the greater the value entered here must be.	
5603	✓ ✓ ✓ ✓		
EN	Voltage control droop	Voltage control: droop	0.0 to 20.0 %
DE	Spannungsregler Statik		
CL2	{0} {1o} {1oc} {2oc}	If this control is to be operated on a generator in parallel with other generators and voltage control is enabled, a droop characteristic curve must be used. Each generator in the system will require the same value to be configured for the droop characteristic, so that when the system is stable the reactive power will be distributed proportionally among all generators in relation to their rated reactive power.	
5604	✓ ✓ ✓ ✓		
EN	Volt. droop act.	Voltage droop active	LogicsManager
DE	Spannungs Statik aktiv		
CL2	{0} {1o} {1oc} {2oc}	If this <i>LogicsManager</i> condition is TRUE, the voltage droop is enabled. The <i>LogicsManager</i> and its default settings are explained on page 273 in Appendix B: " <i>LogicsManager</i> ".	
12905	✓ ✓ ✓ ✓		

Example

Rated reactive power: 400 kvar
 Rated voltage set point: 410 V
 Droop 5.0 %

Reactive power 0 kvar = 0 % of rated power
 Voltage is adjusted to $(410 \text{ V} - [5.0\% * 0.0 * 410 \text{ V}]) = 410 \text{ V}$.

Reactive power 400 kvar = 100 % of rated reactive power
 Voltage is adjusted to $(410 \text{ V} - [5.0\% * 1.0 * 410 \text{ V}]) = 410 \text{ V} - 20.5 \text{ V} = 389.5 \text{ V}$.

EN	Voltage control initial state	Voltage control: initial state	0.0 to 100.0 %
DE	Spannungsregler Grundstellung		
CL2	{0} {1o} {1oc} {2oc}	The value entered for this parameter is the start reference point for the analog output to the voltage controller. If the output to the voltage control has been disabled, the output will act as a control position reference point.	
5608	✓ ✓ ✓ ✓		

Configure Application: Controller, Power Factor Control

Parameter table

Level	Text	Setting range	Default value
Configure power factor control			
	Power factor control	Off / PID analog / 3pos controller	PID analog
	Proportional gain	0.01 to 100.00	1.00
	Integral gain	0.01 to 100.00	1.00
	Derivative ratio	0.01 to 100.00	0.01
	Deadband	0.001 to 0.300	0.010 %
	Time pulse minimum	0.01 to 2.00 s	0.05 s
	Gain factor	0.1 to 10.0	5.0
	Expand deadband factor	1.0 to 9.9	1.0
	Delay expand deadband	1.0 to 9.9 s	2.0 s
	Power factor setpoint 1 source	<i>Analogmanager</i>	05.10
	Int. power factor setpoint 1	-0.710 to 1.000 to +0.710	+1.000
	Power factor setpoint 2 source	<i>Analogmanager</i>	05.11
	Int. power factor setpoint 2	-0.710 to 1.000 to +0.710	+1.000
	Setp. 2 pwr.factor	<i>LogicsManager</i>	(0 & 1) & 1
	React. pwr. ctrl setpoint ramp	0.01 to 100.00 %/s	3.00 %/s

Table 3-103: Application - standard values - configure power factor control

EN	Power factor Control	(0)	(1o)	(1oc)	(2oc)
DE	Leistungsfaktor-Regler				
CL2		✓	✓	✓	✓
5625					

Power factor control: activation **PID analog / 3pos controller / Off**

PID analog ...The power factor is controlled using an analog PID controller.
3pos contr. ...The power factor is controlled using a three-step controller.
OffPower factor control is not carried out.

EN	Proportional gain	(0)	(1o)	(1oc)	(2oc)
DE	Verstärkung				
CL2		✓	✓	✓	✓
5613					

Power factor control: proportional gain **0.01 to 100.00**

ⓘ This parameter is only visible if power factor control (parameter 5625) is configured to "PID analog".

The proportional coefficient specifies the gain. By increasing the gain, the response is increased to permit larger corrections to the variable to be controlled. The farther out of tolerance the process is the larger the response action is to return the process to the tolerance band. If the gain is configured too high, the result is excessive overshoot/undershoot of the desired value.

EN	Integral gain	(0)	(1o)	(1oc)	(2oc)
DE	Integrierbeiwert				
CL2		✓	✓	✓	✓
5614					

Power factor control: integral gain **0.01 to 100.00**

ⓘ This parameter is only visible if power factor control (parameter 5625) is configured to "PID analog".

The integral gain identifies the I part of the PID controller. The integral gain corrects for any offset (between set point and process variable) automatically over time by shifting the proportioning band. Reset automatically changes the output requirements until the process variable and the set point are the same. This parameter permits the user to adjust how quickly the reset attempts to correct for any offset. The integral gain constant must be greater than the derivative time constant. If the integral gain constant is too large, the engine will continually oscillate. If the integral gain constant is too small, the engine will take too long to settle at a steady state.

EN	Derivative ratio				Power factor control: derivative ratio	0.01 to 100.00
DE	Differenzierverhältnis					
CL2 5615	{0}	{1o}	{1oc}	{2oc}	<p>① This parameter is only visible if power factor control (parameter 5625) is configured to "PID analog".</p>	
	✓	✓	✓	✓		

The derivative ratio identifies the D part of the PID controller. By increasing this parameter, the stability of the system is increased. The controller will attempt to slow down the action of the actuator in an attempt to prevent excessive overshoot or undershoot. Essentially this is the brake for the process. This portion of the PID loop operates anywhere within the range of the process unlike reset.

EN	Deadband				Power factor control: deadband	0.001 to 0.300
DE	Unempfindlichkeit					
CL1 5660	{0}	{1o}	{1oc}	{2oc}	<p>① This parameter is only visible if power factor control (parameter 5625) is configured to "3pos controller".</p>	
	✓	✓	✓	✓		

The generator power factor is controlled in such a manner, when paralleled with the mains, so that the monitored power factor does not deviate from the configured power factor set point by more than the value configured in this parameter without the controller issuing a raise/lower signal to the voltage regulator. This prevents unneeded wear on the raise/lower relay contacts. The configured percentage for the dead band refers to the generator rated reactive power (parameter 1758 on page 40).

EN	Time pulse minimum				Power factor control: time pulse minimum	0.01 to 2.00 s
DE	Impulsdauer Minimum					
CL1 5661	{0}	{1o}	{1oc}	{2oc}	<p>① This parameter is only visible if power factor control (parameter 5625) is configured to "3pos controller".</p>	
	✓	✓	✓	✓		

A minimum pulse on time must be configured here. The shortest possible pulse time should be configured to limit overshoot of the desired power factor reference point.

EN	Gain factor				Power factor control: gain factor	0.1 to 10.0
DE	Verstärkungsfaktor					
CL1 5662	{0}	{1o}	{1oc}	{2oc}	<p>① This parameter is only visible if power factor control (parameter 5625) is configured to "3pos controller".</p>	
	✓	✓	✓	✓		

The gain factor K_p influences the operating time of the relays. By increasing the number configured in this parameter, the operating time of the relay will be increased in response to a deviation from the power factor reference. By increasing the gain, the response is increased to permit larger corrections to the variable to be controlled. The farther out of tolerance the process is the larger the response action is to return the process to the tolerance band. If the gain is configured too high, the result is excessive overshoot/undershoot of the desired value.

EN	Expand deadband factor				Power factor control: expand deadband factor	1.0 to 9.9
DE	Aufweitung Unempfindlichkeit					
CL1 5663	{0}	{1o}	{1oc}	{2oc}	<p>① This parameter is only visible if power factor control (parameter 5625) is configured to "3pos controller".</p>	
	✓	✓	✓	✓		

If the measured generator power factor is within the deadband range (parameter 5660) and the configured delay expand deadband time (parameter 5664) expires, the deadband will be multiplied with the factor configured here.

EN	Delay expand deadband			
DE	Verzögerung Aufweitung			
CL1	{0}	{1o}	{1oc}	{2oc}
5664	✓	✓	✓	✓

Power factor control: delay expand deadband 1.0 to 9.9 s

ⓘ This parameter is only visible if power factor control (parameter 5625) is configured to "3pos controller".

The measured generator power factor must be within the deadband range for the time configured here in order to multiply the deadband with the factor configured in parameter 5663.

EN	Power Factor setpoint 1 source			
DE	Cos.phi Sollwert 1 Auswahl			
CL2	{0}	{1o}	{1oc}	{2oc}
5638	✓	✓	✓	✓

Power factor control: power factor setpoint 1 source refer to text below

The power factor setpoint 1 source can be selected from the available data sources. Use the **↑** and **↓** softkeys to scroll through the list of variables and confirm your selection with the **↵** softkey. Even it is possible to select all data sources (refer to Appendix C on page 307), only the following data sources may be used (selecting a different data source may not allow the controller to operate properly):

- 05.10 Internal power factor setpoint 1
Internal power factor control setpoint 1 (parameter 5620) is used as setpoint 1
- 05.11 Internal power factor setpoint 2
Internal power factor control setpoint 2 (parameter 5621) is used as setpoint 1
- 05.12 Interface power factor setpoint
The setpoint, which is transmitted via the interface, is used as setpoint
- 05.16 Discrete raise/lower power factor
The setpoint from the discrete raise/lower power factor function is used as setpoint
- 06.01 Analog input 1
Analog input 1 is used to control the setpoint
- 06.02 Analog input 2
Analog input 2 is used to control the setpoint
- 06.03 Analog input 3
Analog input 3 is used to control the setpoint
- 06.04 Analog input 4
Analog input 4 is used to control the setpoint

The power factor set point may be adjusted between 0.71 leading and 0.71 lagging.



EN	Int: power factor setpoint 1			
DE	Cos.phi Sollwert 1 intern			
CL1	{0}	{1o}	{1oc}	{2oc}
5620	✓	✓	✓	✓

Power factor control: internal power factor set point 1 -0.710 to +0.710

The desired power factor may be configured here so that the reactive power is regulated in the system. The designations "-" and "+" stand for inductive/lagging (generator overexcited) and capacitive/leading (generator underexcited) reactive power. This set point is active only in mains parallel operation.

EN	Power Factor setpoint 2 source			
DE	Cos.phi Sollwert 2 Auswahl			
CL2	{0}	{1o}	{1oc}	{2oc}
5639	✓	✓	✓	✓

Power factor control: power factor setpoint 2 source refer to text below

The power factor setpoint 2 source can be selected from the available data sources. Use the  and  softkeys to scroll through the list of variables and confirm your selection with the  softkey. Even it is possible to select all data sources (refer to Appendix C on page 307), only the following data sources may be used (selecting a different data source may not allow the controller to operate properly):

- 05.10 Internal power factor setpoint 1
Internal power factor control setpoint 1 (parameter 5620) is used as setpoint 2
- 05.11 Internal power factor setpoint 2
Internal power factor control setpoint 2 (parameter 5621) is used as setpoint 2
- 05.12 Interface power factor setpoint
The setpoint, which is transmitted via the interface, is used as setpoint
- 05.16 Discrete raise/lower power factor
The setpoint from the discrete raise/lower power factor function is used as setpoint
- 06.01 Analog input 1
Analog input 1 is used to control the setpoint
- 06.02 Analog input 2
Analog input 2 is used to control the setpoint
- 06.03 Analog input 3
Analog input 3 is used to control the setpoint
- 06.04 Analog input 4
Analog input 4 is used to control the setpoint

The power factor set point may be adjusted between 0.71 leading and 0.71 lagging.

EN	Int: power factor setpoint 2			
DE	Cos.phi Sollwert 2 intern			
CL1	{0}	{1o}	{1oc}	{2oc}
5621	✓	✓	✓	✓

Power factor control: internal power factor set point 2 -0.710 to +0.710

The desired power factor may be configured here so that the reactive power is regulated in the system. The designations "-" and "+" stand for inductive/lagging (generator overexcited) and capacitive/leading (generator underexcited) reactive power. This set point is active only in mains parallel operation.

EN	Setp. 2 pwr.factor			
DE	Cos.phi Soll 2			
CL2	{0}	{1o}	{1oc}	{2oc}
12921	✓	✓	✓	✓

Reactive power set point 2 request *LogicsManager*

If this *LogicsManager* condition is TRUE, the power factor set point 2 will be enabled, i.e. the setting of parameter 5639 overrides the setting of parameter 5638. The *LogicsManager* and its default settings are explained on page 273 in Appendix B: "*LogicsManager*".

EN	React. pwr. ctrl setpoint ramp			
DE	Blindstg.regler Rampe			
CL2	{0}	{1o}	{1oc}	{2oc}
5622	✓	✓	✓	✓

Power factor control: reactive power ramp 0.01 to 100.00 %/s

The different set point values are supplied to the controller via this ramp. The slope of the ramp is used to alter the rate at which the controller modifies the set point value. The faster the change in the set point is to be carried out, the greater the value entered here must be.

Note: This ramp is also used in isolated operation for loading or unloading an additional genset. An excessive oscillation may occur if the ramp is configured too high.

Configure Application: Controller, Load Share Control

The easYgen performs proportional load and/or var sharing. This means each generator will share the load at the same percentage level of the generator rated power when paralleled against the mains, in an isolated operation with multiple generators paralleled, or when re-synchronizing the common bus to the mains. Proportional load/var sharing will not be performed when the easYgen has the GCB closed and is in the constant power/base load mode. A system can consist out of 32 gensets which are controlled by a single easYgen.

Mains parallel operation with mains interchange real power control (import/export)

The easYgen controllers maintain the real load level on the individually controlled generators at a level so that the real power set point at the mains interchange remains at the configured set point. The real power set point for the mains interchange must be configured identically for each easYgen.

The easYgen controller communicates with other controls in the system via a CAN bus. This enables the controllers to adjust the real power generated by the generator while remaining within the rated power of the generator. A smaller generator will contribute less real power as compared to a large generator, but they will both be utilized to the same capacity factor. An example of this would be a 100 kW generator with a configured 1000 kW generator and a mains interchange of 825 kW. The 100 kW generator would contribute 75 kW and the 1000 kW generator would contribute 750 kW or both generators would be at 75% of their rated capacity. Reactive load sharing is not performed when operating in parallel with the mains. The reactive power control will be defined by the configured power factor set point of the individual controllers. If the power factor controller set point is configured as +0.950, the easYgen will proportionally share the real load with all generators in parallel with the mains while controlling the reactive power at a 0.95 inductive (lagging) power factor regardless of the what power factor the mains is operating at.

The parameter "Active power Load share factor" (parameter 5530) can be used now to define the priority of the real power sharing reference variable (real power at interchange). A higher configured percentage influences the control more towards maintaining the real power set point for the interchange. A lower configured percentage influences the control more towards maintaining real power sharing between units.

The parameter "React. power Load share factor" (parameter 5630) has no influence here.

Isolated operation in parallel

The easYgen controllers maintain the voltage and frequency of the individually controlled generators at a constant level. This makes it imperative that the voltage and frequency set points are configured identically for each easYgen.

The easYgen controller communicates with other controls in the system via a CAN bus. This enables the controllers to adjust the real power generated by the generator while remaining within the rated power of the generator. A smaller generator will contribute less real power as compared to a large generator, but they will both be utilized to the same capacity factor. An example of this would be a 100 kW generator and a 1000 kW generator with an 825 kW load. The 100 kW generator would contribute 75 kW and the 1000 kW generator would contribute 750 kW or both generators would be at 75% of their rated capacity.

The reactive power will be shared proportionally among all generators involved.

The parameter "Active power Load share factor" (parameter 5530) can be used to define the priority of the reference variable for real power sharing. A higher configured percentage influences the control more towards frequency control. A lower configured percentage influences the control more towards real power sharing. The parameter "React. power Load share factor" (parameter 5630) can be used now to define the priority of the reference variable for reactive power sharing. A higher configured percentage influences the control more towards voltage control. A lower configured percentage influences the control more towards reactive power sharing.

Re-synchronization of the busbar to the mains

The system is operating as an isolated system, for synchronization to be performed the voltage and frequency differentials of the mains and bus must be within the configured windows.

The bus frequency reference point is dictated by the measured mains frequency and the configured frequency differential (+ slip frequency setpoint offset (parameter 5502 on page 223)).

Example: If + slip frequency setpoint offset = 0.2 Hz, the easYgen will calculate the bus frequency reference point as:

$$[\text{measured mains frequency}] + [\text{slip frequency setpoint offset}] = \text{bus frequency reference point}$$

A practical example of this would be:

The monitored mains frequency is 60 Hz

Configured + slip frequency setpoint offset = 0.2 Hz

$$[60 \text{ Hz}] + [0.2\text{Hz}] = 60.2 \text{ Hz bus frequency reference point}$$

The differential voltage is configured as a window. The monitored voltage from the potential transformers secondary for the mains and the bus must be within the configured voltage differential limit in relation to the rated voltage configuration.

This means that the voltage window dV [%] is in relation to the rated voltage configuration [%].

When the monitored bus frequency and voltage are within the configured differential limits, the "Command: close MCB" relay will enable, closing the MCB, and the system will be paralleled to the mains.

Prerequisites

All easYgen controllers connected to the system must have rated system frequencies and breaker logic configured identically and the parameter "Active power load share" (parameter 5531) or "Reactive power load share" (parameter 5631) must be enabled.

Description of the load-share interface

The easYgen utilizes a peer relationship between units to control the system. This permits for parallel applications of up to 16 generators.



NOTE

Refer to the Interface section of the Installation Manual 37426 for information about the CAN bus connection.

Diagram of load/var sharing via the CAN bus

Refer to Figure 3-29 on page 242 for this diagram. The parameter "Active load sharing factor" determines if and how a generator performs real power or frequency control when paralleled with other generators in an isolated operation. This parameter is defined as a percentage. In the figure below 10 % means increased real power control and 99 % increased frequency control. This parameter must be configured individually for each generator.

In the illustrated control system, it must be noted that each control calculates the mean utilization factor of all controls from the data transmitted via the CAN bus and then compares this with its own utilization factor. The utilization factor is compared with the reference variable and results in a new reference variable set point. Frequency and real power control are carried out simultaneously in these controls (corresponding to the reference variable).

Frequency control is carried out via the measured voltage/frequency of the voltage system. The MPU is used merely for monitoring functions, or is available as a control value to the secondary controller.

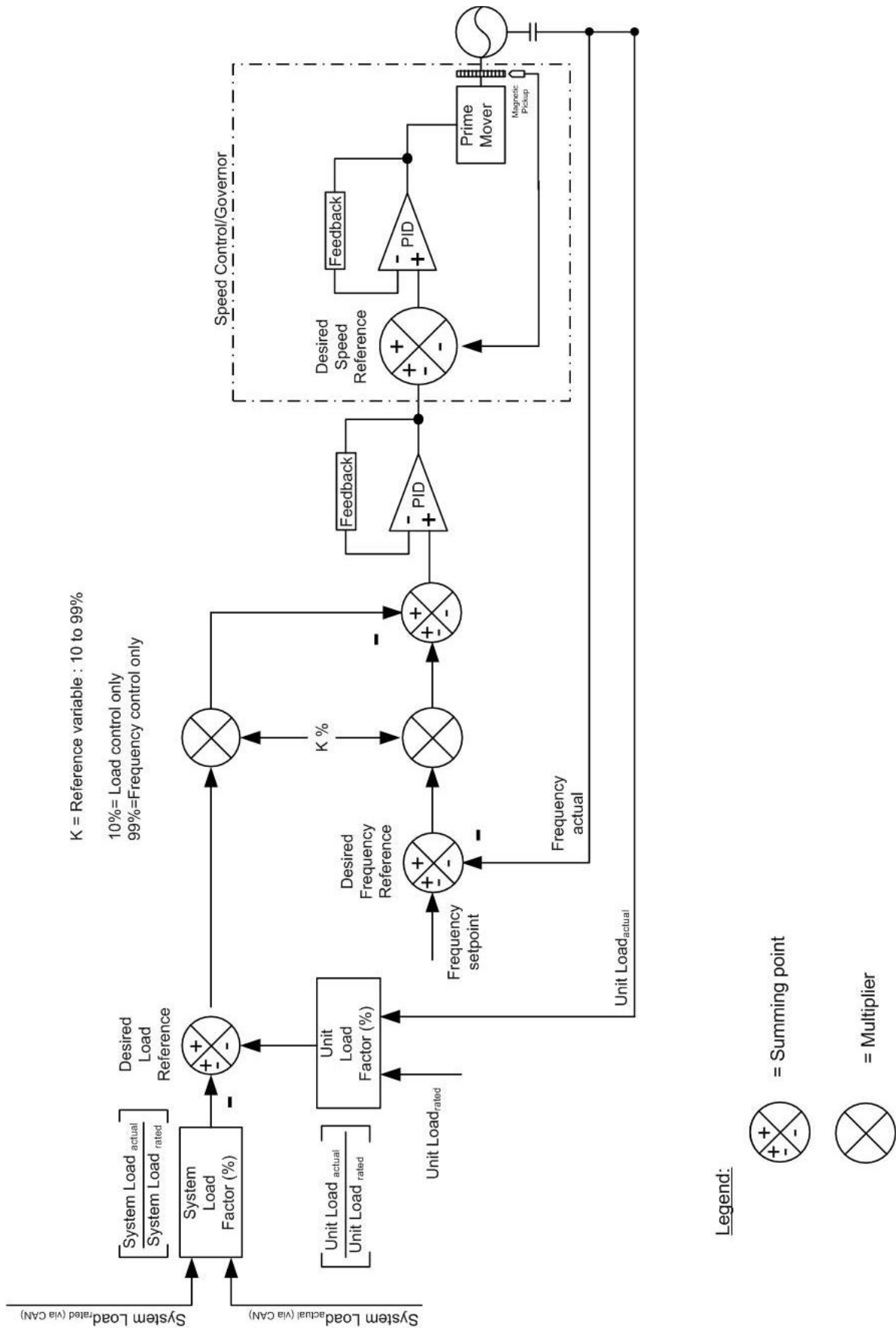

Figure 3-29: CAN bus load/var sharing, diagram

Parameter table

Level	Text	Setting range	Default value
Configure load share			
	Active power load share	On / Off	On
	Active power load share factor	10 to 99 %	50 %
	Reactive power load share	On / Off	On
	React. power load share factor	10 to 99 %	50 %
	Segment number	1 to 32	1
	Segment no.2 act	<i>LogicsManager</i>	(0 & 1) & 1
	Segment no.3 act	<i>LogicsManager</i>	(0 & 1) & 1
	Segment no.4 act	<i>LogicsManager</i>	(0 & 1) & 1
	Mode ext. load share interface	0 to 16	0

Table 3-104: Application - standard values - configure load share

EN	Active power load share			
DE	Wirkleistungsverteilung			
CL2	{0}	{10}	{100}	{200}
5531	✓	✓	✓	✓

Load share control: active power LS activation **On / Off**

On.....Active power load share is enabled. When multiple generators are operating in parallel, the real power is shared proportionally.
Off.....Active power load share is disabled

EN	Active power load share factor			
DE	Wirkl.verteilg. Führungsgr.			
CL2	{0}	{10}	{100}	{200}
5530	✓	✓	✓	✓

Load share control: active power load share factor **10 to 99 %**

It is possible to change the emphasis placed on maintaining control variables. By increasing or decreasing the percentage value in this parameter, the control places a higher priority on maintaining the primary or secondary control reference variable. If the value for this parameter is configured higher, maintaining the primary control variable has a higher priority. If the value for this parameter is configured lower, maintaining the secondary control variable has a higher priority.

Primary control variable

- Isolated operation = frequency maintained
- Mains parallel operation = real power level at the mains interchange point maintained

Secondary control variable

- Isolated operation = real power sharing with other generators maintained
- Mains parallel operation = real power sharing with other generators maintained

The smaller this factor the higher the priority to equally share the load among all generators.

If 99 % is configured here, only the primary control reference variable is considered. If 10 % is configured here, only the secondary control reference variable is considered.

EN	Reactive power load share			
DE	Blindleistungsverteilung			
CL2	{0}	{10}	{100}	{200}
5631	✓	✓	✓	✓

Load share control: reactive power LS activation **On / Off**

On.....Reactive power load share is enabled. When multiple generators are operating in parallel, the reactive power is shared proportionally.
Off.....Reactive power load share is disabled

DE EN CL2 5630	React. power load share factor				
	Blindl.verteilg. Führungsgr.	{0}	{10}	{100}	{200}
		✓	✓	✓	✓

Load share control: reactive power load share factor

10 to 99 %

It is possible to change the emphasis placed on maintaining control variables. By increasing or decreasing the percentage value in this parameter, the control places a higher priority on maintaining the primary or secondary control reference variable. If the value for this parameter is configured higher, maintaining the primary control variable has a higher priority. If the value for this parameter is configured lower, maintaining the secondary control variable has a higher priority.

Primary control variable

- Isolated operation = voltage maintained

Secondary control variable

- Isolated operation = reactive power sharing with other generators maintained

The smaller this factor the higher the priority to equally share the load among all generators.

If 99 % is configured here, only the primary control reference variable is considered. If 10 % is configured here, only the secondary control reference variable is considered.

Configure Application: Controller, Load Share Control, Grouping

Load sharing with several gensets is possible for a supply of a maximum of four split busbars. A group breaker splits the busbar in a way that some gensets supply one busbar and some supply another one. However, it is necessary to group the gensets, which supply the same busbar, into segments.

The configured segment number can be changed to one of three alternative segment numbers. The *LogicsManager* is used to realize this.

Example:

Six gensets (G1 through G6) supply a system with two group breakers (A, B) as shown in Figure 3-30. All gensets have the same segment number configured #1 (parameter 1723)

Case I: Group breakers A and B are closed and G1 through G6 supply the same busbar.

The same segment number is configured to each genset since all gensets supply the same busbar.

Case II: Group breaker A is closed and group breaker B is open (G1 through G4 supply a different busbar than G5 and G6).

A different segment number must be selected for G5 and G6 by enabling the *LogicsManager* function "Segment no.2 act" (parameter 12929) in order to change the segment number of G5 and G6 to #2.

Case III: Group breakers A and B are open (G1 and G2, G3 and G4, as well as G5 and G6 supply different busbars).

A different segment number must be selected for G3 and G4 (*LogicsManager* function "Segment no.2 act" (parameter 12929)) as well as to G5 and G6 (*LogicsManager* function "Segment no.3 act" (parameter 12928)).

With this, the segment number of G3 and G4 is changed to #2 and the segment number of G5 and G6 is changed to #3.

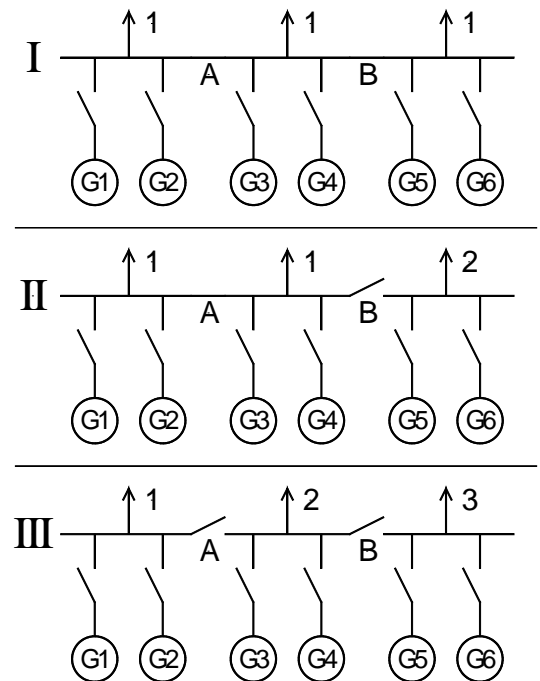

Figure 3-30: Load sharing - grouping

EN	Segment number				
DE	Segmentnummer				
CL2	{0}	{10}	{10c}	{20c}	
1723	✓	✓	✓	✓	

Load share control: segment number

1 to 32

The genset is assigned a load share segment number with this parameter. This segment number may be overridden by the following parameter 12929.

EN	Segment no.2 act				
DE	Segmentnr.2 aktiv				
CL2	{0}	{10}	{10c}	{20c}	
12929	✓	✓	✓	✓	

Load share control: segment number 2 active

LogicsManager

Once the conditions of the *LogicsManager* have been fulfilled, this genset is assigned load share segment number 2. The *LogicsManager* and its default settings are explained on page 273 in Appendix B: "*LogicsManager*".

EN	Segment no.3 act				
DE	Segmentnr.3 aktiv				
CL2	{0}	{10}	{10c}	{20c}	
12928	✓	✓	✓	✓	

Load share control: segment number 3 active

LogicsManager

Once the conditions of the *LogicsManager* have been fulfilled, this genset is assigned load share segment number 3 (this parameter has priority over parameter 12927). The *LogicsManager* and its default settings are explained on page 273 in Appendix B: "*LogicsManager*".

EN	Segment no.4 act				
DE	Segmentnr.4 aktiv				
CL2	{0}	{10}	{10c}	{20c}	
12927	✓	✓	✓	✓	

Load share control: segment number 4 active

LogicsManager

Once the conditions of the *LogicsManager* have been fulfilled, this genset is assigned load share segment number 4. The *LogicsManager* and its default settings are explained on page 273 in Appendix B: "*LogicsManager*".

EN	Mode ext. load share interface				
DE	Modus Ext. Verteilungsmodul				
CL2	{0}	{10}	{10c}	{20c}	
5568	✓	✓	✓	✓	

Load share control: Mode for external load share interface

0 to 16

The operation mode for the external Woodward LSI load share interface is configured here.

- 0..... External load share interface is disabled
- 1..... External load share interface is enabled for Woodward EGCP-2 or GCP-1 connectivity
- 2..... External load share interface is enabled for Woodward SPM-D connectivity
- 3..... External load share interface is enabled for Woodward 2301 A connectivity
- 4..... External load share interface is enabled for Caterpillar LSM 9907-252 connectivity
- 5..... External load share interface is enabled for Caterpillar LSM 9907-173 1 connectivity
- 6..... External load share interface is enabled for Barber Colman POW-R-CON connectivity
- 7 to 16 External load share interface is disabled (reserved settings)

Configure Application: Controller, Discrete Raise/Low/Function

The frequency / load and voltage / reactive power set points may be raised and lowered using the *LogicsManager* functionality, i.e. it is possible to use *LogicsManager* command variables to raise and lower these set points. Most commonly a button may be used to energize a discrete input on the control, which is used again as a *LogicsManager* command variable to enable the respective *LogicsManager* function to change the set point.

The discrete raise/lower function always uses the actual value at the time when this function is enabled for the respective controller set point as initial value. If the actual value is negative at this point in time, the initial value is zero.

Frequency and voltage may be adjusted within the configured operating limits (refer to Configure Monitoring: Generator, Operating Voltage / Frequency on page 50). Active power may be adjusted between 0 and the configured load control setpoint maximum (parameter 5523 on page 229). The power factor may be adjusted between 0.71 leading and 0.71 lagging.

Parameter table

Level	Text	Setting range	Default value
Configure discrete raise/lower function			
	Discrete f/P +	<i>LogicsManager</i>	(0 & 1) & 1
	Discrete f/P -	<i>LogicsManager</i>	(0 & 1) & 1
	Discrete V/PF +	<i>LogicsManager</i>	(0 & 1) & 1
	Discrete V/PF -	<i>LogicsManager</i>	(0 & 1) & 1

Table 3-105: Application - standard values - configure discrete raise/lower function

EN	Discrete f/P +				Setpoints digital poti: raise f/P set point	<i>LogicsManager</i>
DE	Sollwert f/P +					
CL2	{0}	{1o}	{1oc}	{2oc}	Once the conditions of the <i>LogicsManager</i> have been fulfilled, the frequency / load set point will be raised. The <i>LogicsManager</i> and its default settings are explained on page 273 in Appendix B: " <i>LogicsManager</i> ".	
12900	✓	✓	✓	✓		

EN	Discrete f/P -				Setpoints digital poti: lower f/P set point	<i>LogicsManager</i>
DE	Sollwert f/P -					
CL2	{0}	{1o}	{1oc}	{2oc}	Once the conditions of the <i>LogicsManager</i> have been fulfilled, the frequency / load set point will be lowered. The <i>LogicsManager</i> and its default settings are explained on page 273 in Appendix B: " <i>LogicsManager</i> ".	
12901	✓	✓	✓	✓		

EN	Discrete V/PF +				Setpoints digital poti: raise V/Q set point	<i>LogicsManager</i>
DE	Sollwert U/Q +					
CL2	{0}	{1o}	{1oc}	{2oc}	Once the conditions of the <i>LogicsManager</i> have been fulfilled, the voltage / reactive power set point will be raised. The <i>LogicsManager</i> and its default settings are explained on page 273 in Appendix B: " <i>LogicsManager</i> ".	
12902	✓	✓	✓	✓		

EN	Discrete V/PF -				Setpoints digital poti: lower V/Q set point	<i>LogicsManager</i>
DE	Sollwert U/Q -					
CL2	{0}	{1o}	{1oc}	{2oc}	Once the conditions of the <i>LogicsManager</i> have been fulfilled, the voltage / reactive power set point will be lowered. The <i>LogicsManager</i> and its default settings are explained on page 273 in Appendix B: " <i>LogicsManager</i> ".	
12903	✓	✓	✓	✓		



NOTE

The above described parameters can be only configured via ToolKit.

Configure Interfaces



NOTE

Please refer to the Interface Manual 37430 for a detailed description of the interface parameters.

Configure Interfaces: Configure CAN Interfaces (*FlexCAN*)



NOTE

The CAN bus is a field bus and subject to various disturbances. Therefore, it cannot be guaranteed that every request will be answered. We recommend to repeat a request, which is not answered within reasonable time.

Configure CAN Interface 1

Parameter table

Level	Text	Setting range	Default value
Configure CAN interface 1			
	Baudrate	20 / 50 / 100 / 125 / 250 / 500 / 800 / 1000 kBd	250 kBd
	Node-ID CAN-Bus 1	1 to 127 (dec)	1
	CANopen Master	Default Master / On / Off	Default Master
	Producer heartbeat time	0 to 65500 ms	2000 ms
	COB ID SYNC Message	1 to FFFFFFFF hex	80 hex
	Producer SYNC Message time	0 to 65500 ms	20 ms
	COB ID TIME Message	1 to FFFFFFFF hex	100 hex

Table 3-106: Application - standard values - configure CAN interface 1

EN		Baudrate	CAN bus 1: Baud rate	20 / 50 / 100 / 125 / 250 / 500 / 800 / 1,000 kBaud
DE		Baudrate		
CL2	{0}	{10}	{10c}	{20c}
3156	✓	✓	✓	✓
			This parameter defines the used Baud rate. Please note, that all participants on the CAN bus must use the same Baud rate.	
EN		Node-ID CAN-Bus 1	CAN bus 1: Node ID	1 to 127 (dec)
DE		Node-ID CAN-Bus 1		
CL2	{0}	{10}	{10c}	{20c}
8950	✓	✓	✓	✓
			A number that is unique to the control must be set in this parameter so that this control unit can be correctly identified on the CAN bus. This address number may only be used once on the CAN bus. All additional addresses are calculated based on this unique device number.	



NOTE

We recommend to configure the Node-IDs for units, which participate in load sharing, as low as possible to facilitate establishing of communication.

EN	CANopen Master				
DE	CANopen Master				
CL2	{0}	{1o}	{1oc}	{2oc}	
8993	✓	✓	✓	✓	

CAN bus 1: CANopen Master **Default Master / On / Off**

One bus participant must take over the network management and put the other participants into "operational" mode. The easYgen is able to perform this task.

Default Master The unit starts up in "operational" mode and sends a "Start_Remote_node" message after a short delay (the delay is the Node ID (parameter 8950) in seconds, i.e. if the Node ID is configured to 2, the message will be sent after 2 seconds). If more than one easYgen is configured to Default Master, the unit with the lower Node ID will take over control. Therefore, the CAN bus devices, which are intended to act as Default Master should be assigned a low Node ID. No other device on the CAN bus (except the easYgens) may operate as Master).

On The unit is the CANopen Master and automatically changes into operational mode and transmits data.

Off..... The unit is a CANopen Slave. An external Master must change into operational mode.



NOTE

If CANopen Master (parameter 8993) is configured to "Off", the Master controller (for example a PLC) must send a "Start_Remote_node" message to initiate the load share message transmission of the easYgen.

If no "Start_Remote_node" message would be sent, the complete system would not be operational.

EN	Producer heartbeat time				
DE	Producer heartbeat time				
CL2	{0}	{1o}	{1oc}	{2oc}	
9120	✓	✓	✓	✓	

CAN bus 1: Producer heartbeat time **0 to 65500 ms**

Independent from the CANopen Master configuration, the unit transmits a heartbeat message with this configured heartbeat cycle time. If the producer heartbeat time is equal 0, the heartbeat will only be sent as response to a remote frame request. The time configured here will be rounded up to the next 20 ms step.

EN	COB ID SYNC Message				
DE	COB ID SYNC Message				
CL2	{0}	{1o}	{1oc}	{2oc}	
9100	✓	✓	✓	✓	

CAN bus 1: COB ID SYNC Message **1 to FFFFFFFF hex**

This parameter defines whether the unit generates the SYNC message or not.

Complies with CANopen specification: object 1005, subindex 0; defines the COB ID of the synchronization object (SYNC). The structure of this object is shown in the following tables:

UNSIGNED 32 bits	11 bit ID	MSB				LSB
		31	30	29	28-11	10-0
		X	0/1	X	00000000000000000000	11 bit identifier

bit number	value	meaning
31 (MSB)	X	N/A
30	0	Unit does not generate SYNC message
	1	Unit generates SYNC message
29	X	N/A
28-11	0	always
10-0 (LSB)	X	bits 10-0 of SYNC COB ID

EN	Producer SYNC Message time				
DE	Producer SYNC Message time				
CL2	{0}	{1o}	{1oc}	{2oc}	
8940	✓	✓	✓	✓	

CAN bus 1: Sending time for SYNC Message **0 to 65000 ms**

This is the cycle time of the SYNC message. If the unit is configured for this function (parameter 9100) it will send the SYNC message with this interval. The time configured here will be rounded up to the next 10 ms step.

DE EN	COB-ID TIME Message			
	COB-ID TIME Message			
CL2	{0}	{10}	{10c}	{20c}
9101	✓	✓	✓	✓

CAN bus 1: COB ID TIME Message

1 to FFFFFFFF hex

This parameter defines whether the unit generates the TIME message or not.

Complies with CANopen specification: object 1012, subindex 0; defines the COB ID of the time object (TIME). The structure of this object is shown in the following tables:

UNUNSIGNED 32 bits	bits	MSB				LSB
		31	30	29	28-11	10-0
11 bit ID	11 bit ID	X	0/1	X	00000000000000000000	11 bit identifier

bit number	value	meaning
31 (MSB)	X	N/A
30	0	Unit does not generate TIME message
	1	Unit generates TIME message
29	X	N/A
28-11	0	always
10-0 (LSB)	X	bits 10-0 of TIME COB ID

Additional Server SDOs (Service Data Objects)



NOTE

The CAN bus is a field bus and subject to various disturbances. Therefore, it cannot be guaranteed that every request will be answered. We recommend to repeat a request, which is not answered within reasonable time.



NOTE

The first Node ID is the standard Node ID of CAN interface 1 (parameter 8950).

Parameter table

Level	Text	Setting range	Default value
Configure CAN interface 1: additional Server SDOs			
	2. Node ID	0 to 127 (dec)	0
	3. Node ID	0 to 127 (dec)	0
	4. Node ID	0 to 127 (dec)	0
	5. Node ID	0 to 127 (dec)	0

Table 3-107: Application - standard values - configure CAN interface 1: additional Server SDOs

<table border="0"> <tr> <td style="text-align: right;">EN</td> <td style="border: 1px solid black; padding: 2px;">2. Node ID</td> <td></td> <td></td> <td></td> <td></td> </tr> <tr> <td style="text-align: right;">DE</td> <td style="border: 1px solid black; padding: 2px;">2. Node-ID</td> <td></td> <td></td> <td></td> <td></td> </tr> <tr> <td style="text-align: right;">CL2</td> <td style="border: 1px solid black; padding: 2px;">33040</td> <td style="text-align: center;">{0}</td> <td style="text-align: center;">{10}</td> <td style="text-align: center;">{10c}</td> <td style="text-align: center;">{20c}</td> </tr> <tr> <td></td> <td></td> <td style="text-align: center;">✓</td> <td style="text-align: center;">✓</td> <td style="text-align: center;">✓</td> <td style="text-align: center;">✓</td> </tr> </table>	EN	2. Node ID					DE	2. Node-ID					CL2	33040	{0}	{10}	{10c}	{20c}			✓	✓	✓	✓	<p>CAN bus 1: Additional Server SDOs - 2. Node ID 0 to 127 (dec)</p> <hr/> <p>In a multi-master application, each Master needs its own identifier (Node ID) from the unit. in order to send remote signals (i.e. remote start, stop, or acknowledge) to the unit. The additional SDO channel will be made available by configuring this Node ID to a value different than zero. This is the additional CAN ID for the PLC.</p>
EN	2. Node ID																								
DE	2. Node-ID																								
CL2	33040	{0}	{10}	{10c}	{20c}																				
		✓	✓	✓	✓																				
<table border="0"> <tr> <td style="text-align: right;">EN</td> <td style="border: 1px solid black; padding: 2px;">3. Node ID</td> <td></td> <td></td> <td></td> <td></td> </tr> <tr> <td style="text-align: right;">DE</td> <td style="border: 1px solid black; padding: 2px;">3. Node-ID</td> <td></td> <td></td> <td></td> <td></td> </tr> <tr> <td style="text-align: right;">CL2</td> <td style="border: 1px solid black; padding: 2px;">33041</td> <td style="text-align: center;">{0}</td> <td style="text-align: center;">{10}</td> <td style="text-align: center;">{10c}</td> <td style="text-align: center;">{20c}</td> </tr> <tr> <td></td> <td></td> <td style="text-align: center;">✓</td> <td style="text-align: center;">✓</td> <td style="text-align: center;">✓</td> <td style="text-align: center;">✓</td> </tr> </table>	EN	3. Node ID					DE	3. Node-ID					CL2	33041	{0}	{10}	{10c}	{20c}			✓	✓	✓	✓	<p>CAN bus 1: Additional Server SDOs - 3. Node ID 0 to 127 (dec)</p> <hr/> <p>In a multi-master application, each Master needs its own identifier (Node ID) from the unit. in order to send remote signals (i.e. remote start, stop, or acknowledge) to the unit. The additional SDO channel will be made available by configuring this Node ID to a value different than zero. This is the additional CAN ID for the PLC.</p>
EN	3. Node ID																								
DE	3. Node-ID																								
CL2	33041	{0}	{10}	{10c}	{20c}																				
		✓	✓	✓	✓																				
<table border="0"> <tr> <td style="text-align: right;">EN</td> <td style="border: 1px solid black; padding: 2px;">4. Node ID</td> <td></td> <td></td> <td></td> <td></td> </tr> <tr> <td style="text-align: right;">DE</td> <td style="border: 1px solid black; padding: 2px;">4. Node-ID</td> <td></td> <td></td> <td></td> <td></td> </tr> <tr> <td style="text-align: right;">CL2</td> <td style="border: 1px solid black; padding: 2px;">33042</td> <td style="text-align: center;">{0}</td> <td style="text-align: center;">{10}</td> <td style="text-align: center;">{10c}</td> <td style="text-align: center;">{20c}</td> </tr> <tr> <td></td> <td></td> <td style="text-align: center;">✓</td> <td style="text-align: center;">✓</td> <td style="text-align: center;">✓</td> <td style="text-align: center;">✓</td> </tr> </table>	EN	4. Node ID					DE	4. Node-ID					CL2	33042	{0}	{10}	{10c}	{20c}			✓	✓	✓	✓	<p>CAN bus 1: Additional Server SDOs - 4. Node ID 0 to 127 (dec)</p> <hr/> <p>In a multi-master application, each Master needs its own identifier (Node ID) from the unit. in order to send remote signals (i.e. remote start, stop, or acknowledge) to the unit. The additional SDO channel will be made available by configuring this Node ID to a value different than zero. This is the additional CAN ID for the PLC.</p>
EN	4. Node ID																								
DE	4. Node-ID																								
CL2	33042	{0}	{10}	{10c}	{20c}																				
		✓	✓	✓	✓																				
<table border="0"> <tr> <td style="text-align: right;">EN</td> <td style="border: 1px solid black; padding: 2px;">5. Node ID</td> <td></td> <td></td> <td></td> <td></td> </tr> <tr> <td style="text-align: right;">DE</td> <td style="border: 1px solid black; padding: 2px;">5. Node-ID</td> <td></td> <td></td> <td></td> <td></td> </tr> <tr> <td style="text-align: right;">CL2</td> <td style="border: 1px solid black; padding: 2px;">33043</td> <td style="text-align: center;">{0}</td> <td style="text-align: center;">{10}</td> <td style="text-align: center;">{10c}</td> <td style="text-align: center;">{20c}</td> </tr> <tr> <td></td> <td></td> <td style="text-align: center;">✓</td> <td style="text-align: center;">✓</td> <td style="text-align: center;">✓</td> <td style="text-align: center;">✓</td> </tr> </table>	EN	5. Node ID					DE	5. Node-ID					CL2	33043	{0}	{10}	{10c}	{20c}			✓	✓	✓	✓	<p>CAN bus 1: Additional Server SDOs - 5. Node ID 0 to 127 (dec)</p> <hr/> <p>In a multi-master application, each Master needs its own identifier (Node ID) from the unit. in order to send remote signals (i.e. remote start, stop, or acknowledge) to the unit. The additional SDO channel will be made available by configuring this Node ID to a value different than zero. This is the additional CAN ID for the PLC.</p>
EN	5. Node ID																								
DE	5. Node-ID																								
CL2	33043	{0}	{10}	{10c}	{20c}																				
		✓	✓	✓	✓																				

Receive PDO {x} (Process Data Object) [x = 1 to 5]

Figure 3-31 shows the principle of PDO mapping.

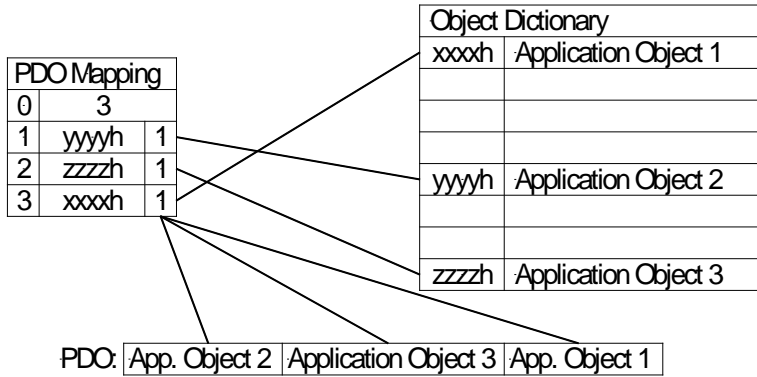

Figure 3-31: Interfaces - Principle of PDO mapping

Parameter table

Level	Text	Setting range	Default value
Configure CAN interface 1: receive PDOs			
	COB-ID	1 to FFFFFFFF hex	80000000 hex
	Event-timer	0 to 65500 ms	2000 ms
	Selected data protocol	0 to 65535	0
	Number of Mapped Objects	0 to 4	0
	1. Mapped Object	0 to 65535	0
	2. Mapped Object	0 to 65535	0
	3. Mapped Object	0 to 65535	0
	4. Mapped Object	0 to 65535	0

Table 3-108: Application - standard values - configure CAN interface 1: receive PDOs

EN	COB-ID	COB-ID
CL2	{0}	{10}
9300	✓	✓
9310	✓	✓
9320	✓	✓

CAN bus 1: Receive PDO {x} - COB ID 1 to FFFFFFFF hex

This parameter contains the communication parameters for the PDOs, the device is able to receive.

Complies with CANopen specification: object 1400 (for RPDO 1, 1401 for RPDO 2 and 1402 for TPDO 3), subindex 1. The structure of this object is shown in the following tables:

UNSIGNED 32 bits	MSB				LSB
11 bit ID	31	30	29	28-11	10-0
	0/1	X	X	00000000000000000000	11 bit identifier

bit number	value	meaning
31 (MSB)	0	PDO exists / is valid
	1	PDO does not exist / is not valid
30	X	N/A
29	X	N/A
28-11	0	always
10-0 (LSB)	X	bits 10-0 of COB ID

PDO valid / not valid allows to select, which PDOs are used in the operational state.

NOTE
 Do not configure an RPDO or TPDO with a COB-ID higher than 580 (hex) or lower than 180 (hex). These IDs are reserved for internal purposes.

EN	Event-timer			
DE	Event-timer			
CL2	{0}	{1o}	{1oc}	{2oc}
9121	✓	✓	✓	✓
9122				
9123				

CAN bus 1: Receive PDO {x} - Event timer **0 to 65500 ms**

This parameter configures the time, from which this PDO is marked as "not existing". The time configured here will be rounded up to the next 5 ms step. Received messages are processed by the control unit every 20 ms. Messages, which are sent faster, will be discarded. We recommend to configure ten times the cycle time of the received data here.

Complies with CANopen specification: object 1400 (for TPDO 1, 1401 for TPDO 2 and 1402 for TPDO 3), subindex 5

EN	Selected Data Protocol			
DE	Ausgewähltes Datenprotocoll			
CL2	{0}	{1o}	{1oc}	{2oc}
8970	✓	✓	✓	✓
8971				
8972				

CAN bus 1: Receive PDO {x} - Selected data protocol **0 to 65535**

A data protocol may be selected by entering the data protocol ID here. If 0 is configured here, the message assembled by the mapping parameters is used. If an unknown data protocol ID is configured here, a failure is indicated by the CAN status bits. Possible data protocol IDs are:

- 65000: IKD 1 – external DIs/DOs 1 through 8
- 65001: IKD 1 – external DIs/DOs 9 through 16
- 65002: IKD 1 – external DIs/DOs 17 through 24
- 65003: IKD 1 – external DIs/DOs 25 through 32

EN	Number of Mapped Objects			
DE	Anzahl der Mapped Objekte			
CL2	{0}	{1o}	{1oc}	{2oc}
9910	✓	✓	✓	✓
9915				
9905				

CAN bus 1: Receive PDO {x} - Number of mapped objects **0 to 4**

This parameter defines the number of valid entries within the mapping record. This number is also the number of the application variables, which shall be received with the corresponding PDO.

Complies with CANopen specification: object 1600 (for RPDO 1, 1601 for RPDO 2 and 1602 for RPDO 3), subindex 0

EN	1. Mapped Object			
DE	1. Mapped Objekt			
CL2	{0}	{1o}	{1oc}	{2oc}
9911	✓	✓	✓	✓
9916				
9906				

CAN bus 1: Receive PDO {x} - 1. mapped object **0 to 65535**

This parameter contains the information about the mapped application variables. These entries describe the PDO contents by their index. The sub-index is always 1. The length is determined automatically.

Complies with CANopen specification: object 1600 (for RPDO 1, 1601 for RPDO 2 and 1602 for RPDO 3), subindex 1

EN	2. Mapped Object			
DE	2. Mapped Objekt			
CL2	{0}	{1o}	{1oc}	{2oc}
9912	✓	✓	✓	✓
9917				
9907				

CAN bus 1: Receive PDO {x} - 2. mapped object **0 to 65535**

This parameter contains the information about the mapped application variables. These entries describe the PDO contents by their index. The sub-index is always 1. The length is determined automatically.

Complies with CANopen specification: object 1600 (for RPDO 1, 1601 for RPDO 2 and 1602 for RPDO 3), subindex 2

EN	3. Mapped Object			
DE	3. Mapped Objekt			
CL2	{0}	{1o}	{1oc}	{2oc}
9913	✓	✓	✓	✓
9918				
9908				

CAN bus 1: Receive PDO {x} - 3. mapped object **0 to 65535**

This parameter contains the information about the mapped application variables. These entries describe the PDO contents by their index. The sub-index is always 1. The length is determined automatically.

Complies with CANopen specification: object 1600 (for RPDO 1, 1601 for RPDO 2 and 1602 for RPDO 3), subindex 3

EN	4. Mapped Object			
DE	4. Mapped Objekt			
CL2	{0}	{1o}	{1oc}	{2oc}
9914	✓	✓	✓	✓
9919				
9909				

CAN bus 1: Receive PDO {x} - 4. mapped object **0 to 65535**

This parameter contains the information about the mapped application variables. These entries describe the PDO contents by their index. The sub-index is always 1. The length is determined automatically.

Complies with CANopen specification: object 1600 (for RPDO 1, 1601 for RPDO 2 and 1602 for RPDO 3), subindex 4

Transmit PDO {x} (Process Data Objects) [x = 1 to 5]

Parameter table

Level	Text	Setting range	Default value
Configure CAN interface 1: transmit PDOs			
	COB-ID	1 to FFFFFFFF hex	80000000 hex
	Transmission type	0 to 255	255
	Event-timer	0 to 65500 ms	20 ms
	Selected data protocol	0 to 65535	0
	Number of Mapped Objects	0 to 4	0
	1. Mapped Object	0 to 65535	0
	2. Mapped Object	0 to 65535	0
	3. Mapped Object	0 to 65535	0
	4. Mapped Object	0 to 65535	0

Table 3-109: Application - standard values - configure CAN interface 1: transmit PDOs

EN	COB-ID			
DE	COB-ID			
CL2	{0}	{1o}	{1oc}	{2oc}
9600	✓	✓	✓	✓
9610				
9620				

CAN bus 1: Transmit PDO {x} - COB ID **1 to FFFFFFFF hex**

This parameter contains the communication parameters for the PDOs the unit is able to transmit. The unit transmits data (i.e. visualization data) on the CAN ID configured here.

Complies with CANopen specification: object 1800 for (TPDO 1, 1801 for TPDO 2 and 1802 for TPDO 3), subindex 1. The structure of this object is shown in the following tables:

UNSIGNED 32 bits	11 bit ID	11 bit ID	MSB			LSB	
			31	30	29	28-11	10-0
			0/1	X	X	000000000000000000	11 bit identifier

bit number	value	meaning
31 (MSB)	0	PDO exists / is valid
	1	PDO does not exist / is not valid
30	X	N/A
29	X	N/A
28-11	0	always
10-0 (LSB)	X	bits 10-0 of COB ID

PDO valid / not valid allows to select, which PDOs are used in the operational state.

NOTE
 Do not configure an RPDO or TPDO with a COB-ID higher than 580 (hex) or lower than 180 (hex). These IDs are reserved for internal purposes.

EN	Transmission type			
DE	Transmission type			
CL2	{0}	{1o}	{1oc}	{2oc}
9602	✓	✓	✓	✓
9612				
9622				

CAN bus 1: Transmit PDO {x} - Transmission type **0 to 255**

This parameter contains the communication parameters for the PDOs the unit is able to transmit. It defines whether the unit broadcasts all data automatically (value 254 or 255) or only upon request with the configured address of the COB ID SYNC message (parameter 9100).

Complies with CANopen specification: object 1800 (for TPDO 1, 1801 for TPDO 2 and 1802 for TPDO 3), subindex 2. The description of the transmission type is shown in the following table:

transmission type	PDO transmission				
	cyclic	acyclic	synchronous	asynchronous	RTR only
0	will not be sent				
1-240	X		X		
241-251	will not be sent				
252	will not be sent				
253	will not be sent				
254				X	
255				X	

A value between 1 and 240 means that the PDO is transferred synchronously and cyclically. The transmission type indicating the number of SYNC, which are necessary to trigger PDO transmissions. Receive PDOs are always triggered by the following SYNC upon reception of data independent of the transmission types 0 to 240. For TPDOs, transmission type 254 and 255 means, the application event is the event timer.

EN	Event timer			
DE	Event-timer			
CL2	{0}	{1o}	{1oc}	{2oc}
9604	✓	✓	✓	✓
9614				
9624				

CAN bus 1: Transmit PDO {x} - Event timer **0 to 65500 ms**

This parameter contains the communication parameters for the PDOs the unit is able to transmit. The broadcast cycle for the transmitted data is configured here. The time configured here will be rounded up to the next 5 ms step.

Complies with CANopen specification: object 1800 (for TPDO 1, 1801 for TPDO 2 and 1802 for TPDO 3), subindex 5

EN	Selected Data Protocol			
DE	Ausgewähltes Datenprotocoll			
CL2	{0}	{1o}	{1oc}	{2oc}
8962	✓	✓	✓	✓
8963				
8964				

CAN bus 1: Transmit PDO {x} - Selected data protocol **0 to 65535**

A data protocol may be selected by entering the data protocol ID here. If 0 is configured here, the message assembled by the mapping parameters is used. If an unknown data protocol ID is configured here, a failure is indicated by the CAN status bits. Possible data protocol IDs are:

- 65000: IKD 1 – external DIs/DOs 1 through 8
- 65001: IKD 1 – external DIs/DOs 9 through 16
- 5100: Data telegram
- 5101: Data telegram
- 5102: Data telegram

EN	Number of Mapped Objects			
DE	Anzahl der Mapped Objekte			
CL2	{0}	{1o}	{1oc}	{2oc}
9609	✓	✓	✓	✓
9619				
9629				

CAN bus 1: Transmit PDO {x} - Number of mapped objects **0 to 4**

This parameter contains the mapping for the PDOs the unit is able to transmit. This number is also the number of the application variables, which shall be transmitted with the corresponding PDO.

Complies with CANopen specification: object 1A00 (for TPDO 1, 1A01 for TPDO 2 and 1A02 for TPDO 3), subindex 0

EN	1. Mapped Object			
DE	1. Mapped Objekt			
CL2	{0}	{1o}	{1oc}	{2oc}
9605	✓	✓	✓	✓
9615				
9625				

CAN bus 1: Transmit PDO {x} - 1. mapped object **0 to 65535**

This parameter contains the information about the mapped application variables. These entries describe the PDO contents by their index. The sub-index is always 1. The length is determined automatically.

Complies with CANopen specification: object 1A00 (for TPDO 1, 1A01 for TPDO 2 and 1A02 for TPDO 3), subindex 1

EN	2. Mapped Object			
DE	2. Mapped Objekt			
CL2	{0}	{1o}	{1oc}	{2oc}
9606	✓	✓	✓	✓
9616				
9626				

CAN bus 1: Transmit PDO {x} - 2. mapped object **0 to 65535**

This parameter contains the information about the mapped application variables. These entries describe the PDO contents by their index. The sub-index is always 1. The length is determined automatically.

Complies with CANopen specification: object 1A00 (for TPDO 1, 1A01 for TPDO 2 and 1A02 for TPDO 3), subindex 2

EN	3. Mapped Object			
DE	3. Mapped Objekt			
CL2	{0}	{1o}	{1oc}	{2oc}
9607	✓	✓	✓	✓
9617				
9627				

CAN bus 1: Transmit PDO {x} - 3. mapped object **0 to 65535**

This parameter contains the information about the mapped application variables. These entries describe the PDO contents by their index. The sub-index is always 1. The length is determined automatically.

Complies with CANopen specification: object 1A00 (for TPDO 1, 1A01 for TPDO 2 and 1A02 for TPDO 3), subindex 3

EN	4. Mapped Object			
DE	4. Mapped Objekt			
CL2	{0}	{1o}	{1oc}	{2oc}
9608	✓	✓	✓	✓
9618				
9628				

CAN bus 1: Transmit PDO {x} - 4. mapped object **0 to 65535**

This parameter contains the information about the mapped application variables. These entries describe the PDO contents by their index. The sub-index is always 1. The length is determined automatically.

Complies with CANopen specification: object 1A00 (for TPDO 1, 1A01 for TPDO 2 and 1A02 for TPDO 3), subindex 4



NOTE

CANopen allows to send 8 byte of data with each Transmit PDO. These may be defined separately if no pre-defined data protocol is used.

All data protocol parameters with a parameter ID may be sent as an object with a CANopen Transmit PDO.

In this case, the data length will be taken from the data byte column (refer to the Data Protocols section in the Interface Manual 37430):

- 1,2 UNSIGNED16 or SIGNED16
- 3,4 UNSIGNED16 or SIGNED16
- 5,6 UNSIGNED16 or SIGNED16
- 1,2,3,4 UNSIGNED32 or SIGNED32
- 3,4,5,6 UNSIGNED32 or SIGNED32
- etc.

The object ID is identical with the parameter ID when configuring via front panel or ToolKit.

Configure CAN Interface 2

Parameter table

Level	Text	Setting range	Default value
Configure CAN interface 2			
	Baudrate	20 / 50 / 100 / 125 / 250 kBd	250 kBd

Table 3-110: Application - standard values - configure CAN interface 2

EN	Baudrate			
DE	Baudrate			
CL2	{0}	{10}	{100}	{200}
3157	✓	✓	✓	✓

CAN bus 2: Baud rate

20 / 50 / 100 / 125 / 250 kBaud

This parameter defines the used Baud rate. Please note, that all participants on the CAN bus must use the same Baud rate.

CANopen Interface

Parameter table

Level	Text	Setting range	Default value
Configure CAN interface 2: CANopen			
	This device	Node-ID 1 / 2 / 3 / 4 / 5 / 6 / 7	Node-ID 7
	IKD1 DI/DO 1..8	Off / Node-ID 1 / 2 / 3 / 4 / 5 / 6 / 7	Off
	IKD1 DI/DO 9..16	Off / Node-ID 1 / 2 / 3 / 4 / 5 / 6 / 7	Off
	IKD1 DI/DO 17..24	Off / Node-ID 1 / 2 / 3 / 4 / 5 / 6 / 7	Off
	IKD1 DI/DO 25..32	Off / Node-ID 1 / 2 / 3 / 4 / 5 / 6 / 7	Off
	Phoenix DI/DO 1..16	Off / Node-ID 1 / 2 / 3 / 4 / 5 / 6 / 7	Off
	Phoenix DI/DO 17..32	Off / Node-ID 1 / 2 / 3 / 4 / 5 / 6 / 7	Off
	Phoenix DI/DO 1..32	Off / Node-ID 1 / 2 / 3 / 4 / 5 / 6 / 7	Off
	Phoenix 12 AI 4AO	Off / Node-ID 1 / 2 / 3 / 4 / 5 / 6 / 7	Off
	Phoenix 16AI 4AO	Off / Node-ID 1 / 2 / 3 / 4 / 5 / 6 / 7	Off
	Phoenix 16AI 4AO DI/DO 1..32	Off / Node-ID 1 / 2 / 3 / 4 / 5 / 6 / 7	Off
	RemoteDisplay	Off / Node-ID 1 / 2 / 3 / 4 / 5 / 6 / 7	Off
	Configure external devices	Yes / No	No

Table 3-111: Application - standard values - configure CAN interface 2: CANopen

EN	This device			
DE	Dieses Gerät			
CL2	{0}	{10}	{100}	{200}
9940	✓	✓	✓	✓

CAN bus 2: Node ID for this device

Node-ID 1 / 2 / 3 / 4 / 5 / 6 / 7

The Node ID for the control unit (this device) is configured here.

EN	IKD1 DI/DO 1..8			
DE	IKD1 DI/DO 1..8			
CL2	{0}	{10}	{100}	{200}
9930	✓	✓	✓	✓

CAN bus 2: Node ID for IKD 1 DI/DO 1-8

Off / Node-ID 1 / 2 / 3 / 4 / 5 / 6 / 7

The unit is pre-configured for the connection of a Woodward IKD 1 expansion board with the discrete inputs/outputs 1 through 8 by configuring a Node ID here.

EN	IKD1 DI/DO 9..16			
DE	IKD1 DI/DO 9..16			
CL2	{0}	{10}	{100}	{200}
9931	✓	✓	✓	✓

CAN bus 2: Node ID for IKD 1 DI/DO 9-16

Off / Node-ID 1 / 2 / 3 / 4 / 5 / 6 / 7

The unit is pre-configured for the connection of a Woodward IKD 1 expansion board with the discrete inputs/outputs 9 through 16 by configuring a Node ID here.

EN	Phoenix DI/DO 1..16				CAN bus 2: Node ID for Phoenix DI/DO 1-16	Off / Node-ID 1 / 2 / 3 / 4 / 5 / 6 / 7
DE	Phoenix DI/DO 1..16					
CL2	{0}	{1o}	{1oc}	{2oc}	The unit is pre-configured for the connection of a Phoenix Contact expansion board with the discrete inputs/outputs 1 through 16 by configuring a Node ID here.	
9934	✓	✓	✓	✓		

EN	Configure external devices				CAN bus 2: Configure external devices	Yes / No
DE	Externe Geräte konfigurieren					
CL2	{0}	{1o}	{1oc}	{2oc}	This parameter starts the configuration of external Phoenix expansion boards.	
15134	✓	✓	✓	✓		

Proceed as follows to configure an external device:

- Connect external device
- Configure parameters at the easYgen (Node ID, DI/Os, AI/Os)
- Set this parameter to Yes
- Verify the successful configuration of the external device

Note: This parameter can only be used to configure a Phoenix expansion board. Refer to the IKD 1 manual 37135 for configuring the IKD 1 expansion boards.

J1939 Interface

Parameter table

Level	Text	Setting range	Default value
Configure CAN interface 2: J1939			
	J1939 device addresses	0 to 255	234
	Engine control address	0 to 255	0
	Reset previous act. DTCs - DM3	Yes / No	No
	Reset act. DTCs - DM3	Yes / No	No
	SPN version	Version 1 / Version 2 / Version 3	Version 1
	Device type	Off / Standard / S6 Scania / EMR2 Deutz / EMS 2 Volvo / ADEC MTU / EGS Woodward / EDC7 MAN / EEM SISU / Cummins	Standard
	ECU remote controlled	On / Off	On
	Speed deviation ECU	0 to 1400 rpm	120 rpm

Table 3-112: Application - standard values - configure CAN interface 2: J1939

EN	J1939 device addresses
DE	J1939 Geräte-Adresse
CL2 15106	{0} ✓ {10} ✓ {10c} ✓ {20c} ✓

J1939 Interface: Own address **0 to 255**

The easYgen sends J1939 request and control messages with this ID. It must be changed for different ECU types according to the following table. The ECU listens only to control messages, if they are sent to the correct address.

S6 Scania	EMR2 Deutz	EMS2 Volvo	ADEC MTU	EGS Woodward	EDC7 MAN	EEM SISU	Cummins
39	3	17	1	234	253	n/a	220

Details may be found in the manual of the genset control and the interface manual 37430.

Note: Changing this parameter becomes only effective after restarting the unit.

EN	Engine control address
DE	Adresse Motorsteuerung
CL2 15107	{0} ✓ {10} ✓ {10c} ✓ {20c} ✓

J1939 Interface: Engine control address **0 to 255**

Configures the address of the J1939 device, which is controlled.

S6 Scania	EMR2 Deutz	EMS2 Volvo	ADEC MTU	EGS Woodward	EDC7 MAN	EEM SISU	Cummins
0	0	0	128	0	39	0 / (1)	0

EN	Reset previous act. DTCs - DM3
DE	Quittieren passiver Fehler DM3
CL2 15108	{0} ✓ {10} ✓ {10c} ✓ {20c} ✓

J1939 Interface: Reset previously active DTCs - DM3 **Yes / No**

If this parameter is set Yes, a DM3 message "Acknowledge passive faults" is sent. After that this parameter is reset automatically to No. As a result alarms (DM2) which no longer apply are cleared.

EN	Reset act. DTCs - DM11
DE	Quittieren activer Fehler DM11
CL2 15133	{0} ✓ {10} ✓ {10c} ✓ {20c} ✓

J1939 Interface: Reset active DTCs - DM11 **Yes / No**

If this parameter is set Yes, a DM11 message "Acknowledge active faults" is sent. After that this parameter is reset automatically to No. As a result alarms (DM1) which no longer apply are cleared.

EN	SPN version
DE	SPN Version
CL2 15103	{0} ✓ {10} ✓ {10c} ✓ {20c} ✓

J1939 Interface: SPN version **Version 1 / Version 2 / Version 3**

The J1939 protocol provides 4 different versions for formatting Suspect Parameter Number. This is important for a correct display of the alarm messages. With this parameter it is defined if formatting occurs according to Version 1, Version 2, or Version 3. Formatting according to Version 4 is identified automatically.

Details may be found in the engine control J1939 manual.

EN	Device type				
	Betriebsmodus				
CL2	{0}	{1o}	{1oc}	{2oc}	
15102	✓	✓	✓	✓	

J1939 Interface: Device type refer to selection below

The J1939 interface of this device may be operated with different engine control units or analog input devices. This parameter determines the operating mode of the used ECU.

- Off**..... The J1939 interface is disabled. No messages will be received.
- Standard** Standard J1939 coupling is enabled: J1939 data is displayed according to the SAE J1939 standard.
This setting must be configured for all J1939 ECUs, which cannot be selected here (e.g. Deutz EMR3, John Deere, Perkins, Iveco, Sisu, etc.).
- S6 Scania** The **Scania EMS/S6** ECU is enabled: J1939 data according to the SAE J1939 standard **and** some S6-specific data are considered.
- EMR2 Deutz** The **Deutz EMR2** ECU is enabled: J1939 data according to the SAE J1939 standard **and** some EMR2-specific data are considered.
- EMS2 Volvo** The **Volvo EMS2** ECU is enabled: J1939 data according to the SAE J1939 standard **and** some EMS2-specific data are considered.
- ADEC MTU** The **MTU ADEC** ECU is enabled: J1939 data according to the SAE J1939 standard **and** some ADEC-specific data are considered.
- EGS Woodward ...** The **Woodward EGS** ECU is enabled: J1939 data according to the SAE J1939 standard **and** some EGS-specific data are considered.
- EDC7 MAN** The **MAN EDC7** ECU is enabled: J1939 data according to the SAE J1939 standard **and** some EDC-specific data are considered.
- EEM SISU** The **SISU EEM2/3** ECU is enabled: J1939 data according to the SAE J1939 standard **and** some EEM2/3-specific data are considered.
- Cummins** The **Cummins** ECU is enabled: J1939 data according to the SAE J1939 standard **and** some Cummins-specific data are considered.



NOTE

Refer to the Appendix of the Interface Manual 37430 for a list of all ECUs, which are supported beyond the J1939 standard.

This parameter must not be disabled if any J1939 device (like an analog input device) is connected to the easYgen, even if no ECU is connected!

EN	ECU remote controlled				
	Fernsteuern der ECU über J1939				
CL2	{0}	{1o}	{1oc}	{2oc}	
15127	✓	✓	✓	✓	

J1939 Interface: ECU remote control via J1939 On / Off

- On**..... The unit sends J1939 control messages to the ECU. Depending on the selected device type (Parameter 15102), contains a specific selection of commands. Available messages are speed deviation and droop for all ECUs as well as engine start/stop, enable idle mode, rated speed switch and preglow for some ECUs. Refer to the interface manual 37430 for more detailed information.
- Off**..... The ECU remote control via the J1939 protocol will be disabled.



NOTE

The unit sends J1939 control messages to the ECU. Depending on the selected device type (Parameter 15102), it contains a specific selection of commands. Available messages are speed deviation and droop for ECUs as well as engine start/stop, enable idle mode, rated speed switch and preglow for some ECUs. Refer to the interface manual 37430 for more detailed information.

EN	Speed deviation ECU				
DE	Drehzahlhub				
CL2	{0}	{10}	{100}	{200}	
5537	✓	✓	✓	✓	

J1939 Interface: Speed deviation

0 to 1400 rpm

i This parameter is only visible if ECU remote controlled (parameter 15127) is configured to "On".

This parameter adjusts the range of the speed deviation around the rated speed, which is sent to the ECU.

It relates to the engine rated speed (parameter 1601). There are two methods of sending the speed set point to the ECU: With a speed offset and a speed setpoint. The frequency and power control must be configured to "PID".

Speed offset: S6 Scania, EMS2 Volvo, EGS Woodward, Cummins

The easYgen sends a speed offset with a range of 0 to 100% (every 20 ms). 50% = rated speed. There is also an internal speed offset configured in the ECU, this parameter determines what corresponds with 0% or 100%. If there is a positive and a negative speed offset, they should be symmetrical in the ECU. We recommend to have the same speed offset configured in the ECU and in this parameter here. A different setting will result in an additional "controller gain".

How to test this parameter during commissioning:

Isolated operation: Disable the frequency controller and change parameter 5508 for the initial state between 0 and 100%, the engine should change the speed as follows:

- 0 = rated speed – negative speed offset from ECU
- 50 = rated speed
- 100 = rated speed + positive speed offset from ECU

Mains parallel operation: Check with the set point in the display if the engine is able to deliver the full power.

Speed set point: EMR2 Deutz, ADEC MTU, EGS Woodward, EEM SISU, Standard

The easYgen sends a speed set point in rpm (every 10 ms) that varies around the rated speed in the range of +/- the speed deviation.

How to test this parameter during commissioning:

Isolated operation: Disable the frequency controller and change parameter 5508 for the initial state between 0 and 100%, the engine should change the speed as follows:

- 0 = rated speed – speed deviation ECU e.g. 1500 – 120 = 1380rpm
- 50 = rated speed e.g. = 1500rpm
- 100 = rated speed + speed deviation ECU e.g. 1500 + 120 = 1620rpm

Note: Keep this value as small as possible, i.e. do not enter a speed deviation of 500, if the engine varies only between 1400 and 1600rpm.

Mains parallel operation: Check with the set point in the display if the engine is able to deliver the full power.



NOTE

The Woodward EGS ECU supports both types of speed deviation control and may be configured either to "Speed offset" or "Speed set point".

In mains parallel operation, the EGS can be configured to receive a real power set point from the easYgen to control the power. In this case, real power control must be disabled in the easYgen.

Load Share Parameters

Parameter table

Level	Text	Setting range	Default value
Configure CAN interface: load share			
	Load share Interface	CAN #1 / Off	CAN #1
	Transfer rate LS fast message	0.10 to 0.30 s	0.10 s
	Load Share CAN-ID	2xx Hex / 3xx Hex 4xx Hex / 5xx Hex	5xx Hex

Table 3-113: Application - standard values - configure CAN interface: load share

EN	Load share Interface	CAN Interface: load share interface	CAN #1 / Off
DE	Schnittstelle Lastverteilung		
CL2	{0} {10} {10c} {20c}	The interface, which is used for transmitting the load share data is configured here.	
9923	✓ ✓ ✓ ✓		
EN	Transfer rate LS fast message	CAN Interface: transfer rate load share fast message	0.10 to 0.30 s
DE	Sendetakt der Lastverteilung		
CL2	{0} {10} {10c} {20c}	The transfer rate defines the time delay between two fast CAN messages. In case of CAN systems with a high bus load (e.g. long distance between the units with low baud rate), a shorter transfer rate (higher time setting) helps to reduce the bus load.	
9921	✓ ✓ ✓ ✓		
EN	Load Share CAN-ID	CAN Interface: load share CAN ID	2xx Hex / 3xx Hex / 4xx Hex / 5xx Hex
DE	Lastverteilungs CAN-ID		
CL2	{0} {10} {10c} {20c}	The first digit of the CAN ID or the range (i.e. 2xx means 200 through 2FF) is configured here. The last two digits will be assigned by the control with the settings from the device number (parameter 1702 on page 33).	
9920	✓ ✓ ✓ ✓		

Configure Interfaces: Configure RS-232 Interfaces

Configure Serial Interface 1

Parameter table

Level	Text	Setting range	Default value
Configure RS-232 interfaces: serial interface 1			
	Baudrate	2.4 / 4.8 / 9.6 / 14.4 / 19.2 38.4 / 56 / 115 kBd	19.2 kBd
	Parity	No / Even / Odd	No
	Stop bits	One / Two	One
	ModBus Slave ID	0 to 255	1
	Reply delay time	0.00 to 1.00 s	0.00 s

Table 3-114: Application - standard values - configure RS-232 interface: serial interface 1

EN	Baudrate				
DE	Baudrate				
CL2	{0}	{1o}	{1oc}	{2oc}	
3163	✓	✓	✓	✓	

Serial interface 1: Baud rate **2.4 / 4.8 / 9.6 / 14.4 / 19.2 / 38.4 / 56 / 115 kBaud**

This parameter defines the baud rate for communications. Please note, that all participants on the bus must use the same baud rate.

EN	Parity				
DE	Parity				
CL2	{0}	{1o}	{1oc}	{2oc}	
3161	✓	✓	✓	✓	

Serial interface 1: Parity **no / even / odd**

The used parity of the interface is set here.

EN	Stop bits				
DE	Stop Bits				
CL2	{0}	{1o}	{1oc}	{2oc}	
3162	✓	✓	✓	✓	

Serial interface 1: Stop bits **one / two**

The number of stop bits is set here.

EN	ModBus Slave ID				
DE	ModBus Slave ID				
CL2	{0}	{1o}	{1oc}	{2oc}	
3185	✓	✓	✓	✓	

Serial interface 1: Modbus Slave ID **0 to 255**

The Modbus device address, which is used to identify the device via Modbus, is entered here. If "0" is configured here, the Modbus is disabled.

EN	Reply delay time				
DE	Zeitverzöger. der Antwort				
CL2	{0}	{1o}	{1oc}	{2oc}	
3186	✓	✓	✓	✓	

Serial interface 1: Reply delay time **0.00 to 1.00 s**

This is the minimum delay time between a request from the Modbus master and the sent response of the slave. This time is also required if an external interface converter to RS-485 is used for example.

Configure Interfaces: Configure RS-485 Interfaces

Configure Serial Interface 2

Parameter table

Level	Text	Setting range	Default value
Configure RS-232 interfaces: serial interface 1			
	Baudrate	2.4 / 4.8 / 9.6 / 14.4 / 19.2 38.4 / 56 / 115 kBd	19.2 kBd
	Parity	No / Even / Odd	No
	Stop bits	One / Two	One
	ModBus Slave ID	0 to 255	1
	Reply delay time	0.00 to 2.55 s	0.00 s

Table 3-115: Application - standard values - configure RS-485 interface: serial interface 2

EN	Baudrate			
DE	Baudrate			
CL2	{0}	{1o}	{1oc}	{2oc}
3170	✓	✓	✓	✓

Serial interface 2: Baud rate **2.4 / 4.8 / 9.6 / 14.4 / 19.2 / 38.4 / 56 / 115 kBaud**

This parameter defines the baud rate for communications. Please note, that all participants on the bus must use the same baud rate.

EN	Parity			
DE	Parity			
CL2	{0}	{1o}	{1oc}	{2oc}
3171	✓	✓	✓	✓

Serial interface 2: Parity **no / even / odd**

The used parity of the interface is set here.

EN	Stop bits			
DE	Stop Bits			
CL2	{0}	{1o}	{1oc}	{2oc}
3172	✓	✓	✓	✓

Serial interface 2: Stop bits **one / two**

The number of stop bits is set here.

EN	ModBus Slave ID			
DE	ModBus Slave ID			
CL2	{0}	{1o}	{1oc}	{2oc}
3188	✓	✓	✓	✓

Serial interface 2: Modbus Slave ID **0 to 255**

The Modbus device address, which is used to identify the device via Modbus, is entered here. If "0" is configured here, the Modbus is disabled.

EN	Reply delay time			
DE	Zeitverzöger. der Antwort			
CL2	{0}	{1o}	{1oc}	{2oc}
3189	✓	✓	✓	✓

Serial interface 2: Reply delay time **0.00 to 2.55 s**

This is the minimum delay time between a request from the Modbus master and the sent response of the slave. This time is required in halfduplex mode.

Configure *LogicsManager*



Parameter table

Level	Text	Setting range	Default value
Configure <i>LogicsManager</i>			
	Flag {x}	<i>LogicsManager</i>	(0 & 1) & 1
	Timer 1: Hour	0 to 23 h	8 h
	Timer 1: Minute	0 to 59 min	0 min
	Timer 1: Second	0 to 59 s	0 s
	Timer 2: Hour	0 to 23 h	17 h
	Timer 2: Minute	0 to 59 min	0 min
	Timer 2: Second	0 to 59 s	0 s
	Active day	1 to 31	1
	Active hour	0 to 23	12
	Active minute	0 to 59 min	0 min
	Active second	0 to 59 s	0 s
	Monday active	Yes / No	Yes
	Tuesday active	Yes / No	Yes
	Wednesday active	Yes / No	Yes
	Thursday active	Yes / No	Yes
	Friday active	Yes / No	Yes
	Saturday active	Yes / No	No
	Sunday active	Yes / No	No
	Use ASA symbols	Yes / No	No

Table 3-116: Application - standard values - configure *LogicsManager*

The easYgen *LogicsManager* screens show logical symbols according to the IEC standard by default. However, it is also possible to change the *LogicsManager* screens to ASA standard. Table 3-120 on page 274 shows the symbols according to the different standards.

EN	Use ASA symbols	Use ASA symbols	Yes / No
DE	ASA Symbole verwenden		
CL2	{0} {1o} {1oc} {2oc}	Yes	Symbols according to the ASA standard are used in <i>LogicsManager</i> screens.
4117	✓ ✓ ✓ ✓	No.....	Symbols according to the IEC standard are used in <i>LogicsManager</i> screens.

Configure *LogicsManager*: Configure Internal Flags

Internal flags within the *LogicsManager* logical outputs may be programmed and used for multiple functions. For conditions and explanation of programming please refer to page 273 in chapter "*LogicsManager*".

EN	Flag {x}	Internal flags: Flag {x} [x = 1 to 16]	<i>LogicsManager</i>
DE	Merker {x}		
CL2	{0} {1o} {1oc} {2oc}	The flags may be used as auxiliary flags for complex combinations by using the logical output of these flags as command variable for other logical outputs.	
yyyyy	✓ ✓ ✓ ✓		

Flag {x}	Flag 1	Flag 2	Flag 3	Flag 4	Flag 5	Flag 6	Flag 7	Flag 8
Parameter ID yyyyy	12230	12240	12250	12260	12270	12280	12290	12300
Flag {x}	Flag 9	Flag 10	Flag 11	Flag 12	Flag 13	Flag 14	Flag 15	Flag 16
Parameter ID yyyyy	12910	12911	12912	12913	12914	12915	12916	12917

Table 3-117: Internal flags - parameter IDs



NOTE

Flag 1 is also used as placeholder in other logical combinations. Flag 8 is preset with a timer start and shows different default values compared with Table 3-116.

Configure *LogicsManager*: Set Timer

LogicsManager: Daily Time Set Point

Utilizing the *LogicsManager* it is possible to establish specific times of the day that functions (i.e. generator exerciser) can be enabled. The two daily time set points are activated each day at the configured time. Using the *LogicsManager* these set points may be configured individually or combined to create a time range.

<table border="0"> <tr> <td>EN</td> <td colspan="4">Timer {x}: Hour</td> </tr> <tr> <td>DE</td> <td colspan="4">Zeitpunkt {x}: Stunde</td> </tr> <tr> <td>CL2</td> <td>{0}</td> <td>{1o}</td> <td>{1oc}</td> <td>{2oc}</td> </tr> <tr> <td>1652</td> <td>✓</td> <td>✓</td> <td>✓</td> <td>✓</td> </tr> <tr> <td>1657</td> <td></td> <td></td> <td></td> <td></td> </tr> </table>	EN	Timer {x}: Hour				DE	Zeitpunkt {x}: Stunde				CL2	{0}	{1o}	{1oc}	{2oc}	1652	✓	✓	✓	✓	1657					<p>Timer: Daily time set point {x} [x = 1/2]: hour 0 to 23 h</p> <hr/> <p>Enter the hour of the daily time set point here. Example: 00th hour of the day (midnight). 2323rd hour of the day (11pm).</p>
EN	Timer {x}: Hour																									
DE	Zeitpunkt {x}: Stunde																									
CL2	{0}	{1o}	{1oc}	{2oc}																						
1652	✓	✓	✓	✓																						
1657																										

<table border="0"> <tr> <td>EN</td> <td colspan="4">Timer {x}: Minute</td> </tr> <tr> <td>DE</td> <td colspan="4">Zeitpunkt {x}: Minute</td> </tr> <tr> <td>CL2</td> <td>{0}</td> <td>{1o}</td> <td>{1oc}</td> <td>{2oc}</td> </tr> <tr> <td>1651</td> <td>✓</td> <td>✓</td> <td>✓</td> <td>✓</td> </tr> <tr> <td>1656</td> <td></td> <td></td> <td></td> <td></td> </tr> </table>	EN	Timer {x}: Minute				DE	Zeitpunkt {x}: Minute				CL2	{0}	{1o}	{1oc}	{2oc}	1651	✓	✓	✓	✓	1656					<p>Timer: Daily time set point {x} [x = 1/2]: minute 0 to 59 min</p> <hr/> <p>Enter the minute of the daily time set point here. Example: 00th minute of the hour. 5959th minute of the hour.</p>
EN	Timer {x}: Minute																									
DE	Zeitpunkt {x}: Minute																									
CL2	{0}	{1o}	{1oc}	{2oc}																						
1651	✓	✓	✓	✓																						
1656																										

<table border="0"> <tr> <td>EN</td> <td colspan="4">Timer {x}: Second</td> </tr> <tr> <td>DE</td> <td colspan="4">Zeitpunkt {x}: Sekunde</td> </tr> <tr> <td>CL2</td> <td>{0}</td> <td>{1o}</td> <td>{1oc}</td> <td>{2oc}</td> </tr> <tr> <td>1650</td> <td>✓</td> <td>✓</td> <td>✓</td> <td>✓</td> </tr> <tr> <td>1655</td> <td></td> <td></td> <td></td> <td></td> </tr> </table>	EN	Timer {x}: Second				DE	Zeitpunkt {x}: Sekunde				CL2	{0}	{1o}	{1oc}	{2oc}	1650	✓	✓	✓	✓	1655					<p>Timer: Daily time set point {x} [x = 1/2]: second 0 to 59 s</p> <hr/> <p>Enter the second of the daily time set point here. Example 00th second of the minute. 5959th second of the minute.</p>
EN	Timer {x}: Second																									
DE	Zeitpunkt {x}: Sekunde																									
CL2	{0}	{1o}	{1oc}	{2oc}																						
1650	✓	✓	✓	✓																						
1655																										

LogicsManager: Active Time Set Point

Utilizing the *LogicsManager* it is possible to establish specific days (or hours, minutes, seconds) that functions (i.e. generator exerciser) can be enabled. The active switching point is activated only on a specified day (or hour, minute, second). The set points may be configured individually or combined via the *LogicsManager*. You may configure monthly, daily, hourly, minutely, or even secondly time set points depending on how you combine the set points in the *LogicsManager*.

<table border="0"> <tr> <td>EN</td> <td colspan="4">Active day</td> </tr> <tr> <td>DE</td> <td colspan="4">Aktiver Tag</td> </tr> <tr> <td>CL2</td> <td>{0}</td> <td>{1o}</td> <td>{1oc}</td> <td>{2oc}</td> </tr> <tr> <td>1663</td> <td>✓</td> <td>✓</td> <td>✓</td> <td>✓</td> </tr> </table>	EN	Active day				DE	Aktiver Tag				CL2	{0}	{1o}	{1oc}	{2oc}	1663	✓	✓	✓	✓	<p>Timer: Active time set point: day 1 to 31</p> <hr/> <p>Enter the day of the active switch point here. Example: 011st day of the month. 3131st day of the month. The active time set point is enabled during the indicated day from 0:00:00 hours to 23:59:59 hours.</p>
EN	Active day																				
DE	Aktiver Tag																				
CL2	{0}	{1o}	{1oc}	{2oc}																	
1663	✓	✓	✓	✓																	

<table border="0"> <tr> <td>EN</td> <td colspan="4">Active hour</td> </tr> <tr> <td>DE</td> <td colspan="4">Aktive Stunde</td> </tr> <tr> <td>CL2</td> <td>{0}</td> <td>{1o}</td> <td>{1oc}</td> <td>{2oc}</td> </tr> <tr> <td>1662</td> <td>✓</td> <td>✓</td> <td>✓</td> <td>✓</td> </tr> </table>	EN	Active hour				DE	Aktive Stunde				CL2	{0}	{1o}	{1oc}	{2oc}	1662	✓	✓	✓	✓	<p>Timer: Active time set point: hour 0 to 23 h</p> <hr/> <p>Enter the hour of the active switch point here. Example: 00th hour of the day. 2323rd hour of the day. The active time set point is enabled every day during the indicated hour from minute 0 to minute 59.</p>
EN	Active hour																				
DE	Aktive Stunde																				
CL2	{0}	{1o}	{1oc}	{2oc}																	
1662	✓	✓	✓	✓																	

<table border="0"> <tr> <td>EN</td> <td colspan="4">Active minute</td> </tr> <tr> <td>DE</td> <td colspan="4">Aktive Minute</td> </tr> <tr> <td>CL2</td> <td>{0}</td> <td>{1o}</td> <td>{1oc}</td> <td>{2oc}</td> </tr> <tr> <td>1661</td> <td>✓</td> <td>✓</td> <td>✓</td> <td>✓</td> </tr> </table>	EN	Active minute				DE	Aktive Minute				CL2	{0}	{1o}	{1oc}	{2oc}	1661	✓	✓	✓	✓	<p>Timer: Active time set point: minute 0 to 59 min</p> <hr/> <p>Enter the minute of the active switch point here. Example: 00th minute of the hour. 5959th minute of the hour. The active time set point is enabled every hour during the indicated minute from second 0 to second 59.</p>
EN	Active minute																				
DE	Aktive Minute																				
CL2	{0}	{1o}	{1oc}	{2oc}																	
1661	✓	✓	✓	✓																	

EN	Active second				Timer: Active time set point: second	0 to 59 s
DE	Aktive Sekunde					
CL2	{0}	{1s}	{1oc}	{2oc}	Enter the second of the active switch point here. Example:	
1660	✓	✓	✓	✓	0 0 th second of the minute. 59 59 th second the minute. The active time set point is enabled every minute during the indicated second.	

LogicsManager: Weekly Time Set Point

Utilizing the *LogicsManager* it is possible to establish specific days of the week that functions (i.e. generator exerciser) can be enabled. The weekly time set point is enabled during the indicated day from 0:00:00 hours to 23:59:59 hours.

EN	Monday active				Timer: Weekly time set points Monday: days	Yes / No
DE	Montag aktiv					
CL2	{0}	{1s}	{1oc}	{2oc}	Please enter the days of the weekly workdays.	
1670	✓	✓	✓	✓	Monday <i>Yes</i> - The switch point is enabled every Monday <i>No</i> - The switch point is disabled every Monday	

EN	Tuesday active				Timer: Weekly time set points Tuesday: days	Yes / No
DE	Dienstag aktiv					
CL2	{0}	{1s}	{1oc}	{2oc}	Please enter the days of the weekly workdays.	
1671	✓	✓	✓	✓	Tuesday <i>Yes</i> - The switch point is enabled every Tuesday <i>No</i> - The switch point is disabled every Tuesday	

EN	Wednesday active				Timer: Weekly time set points Wednesday: days	Yes / No
DE	Mittwoch aktiv					
CL2	{0}	{1s}	{1oc}	{2oc}	Please enter the days of the weekly workdays.	
1672	✓	✓	✓	✓	Wednesday <i>Yes</i> - The switch point is enabled every Wednesday <i>No</i> - The switch point is disabled every Wednesday	

EN	Thursday active				Timer: Weekly time set points Thursday: days	Yes / No
DE	Donnerstag aktiv					
CL2	{0}	{1s}	{1oc}	{2oc}	Please enter the days of the weekly workdays.	
1673	✓	✓	✓	✓	Thursday <i>Yes</i> - The switch point is enabled every Thursday <i>No</i> - The switch point is disabled every Thursday	

EN	Friday active				Timer: Weekly time set points Friday: days	Yes / No
DE	Freitag aktiv					
CL2	{0}	{1s}	{1oc}	{2oc}	Please enter the days of the weekly workdays.	
1674	✓	✓	✓	✓	Friday <i>Yes</i> - The switch point is enabled every Friday <i>No</i> - The switch point is disabled every Friday	

EN	Saturday active				Timer: Weekly time set points Saturday: days	Yes / No
DE	Samstag aktiv					
CL2	{0}	{1s}	{1oc}	{2oc}	Please enter the days of the weekly workdays.	
1675	✓	✓	✓	✓	Saturday <i>Yes</i> - The switch point is enabled every Saturday <i>No</i> - The switch point is disabled every Saturday	

EN	Sunday active				Timer: Weekly time set points Sunday: days	Yes / No
DE	Sonntag aktiv					
CL2	{0}	{1s}	{1oc}	{2oc}	Please enter the days of the weekly workdays.	
1676	✓	✓	✓	✓	Sunday <i>Yes</i> - The switch point is enabled every Sunday <i>No</i> - The switch point is disabled every Sunday	

Configure Counters



Parameter table

Level	Text	Setting range	Default value
Configure counters			
	Maintenance hours	0 to 9999 h	300 h
	Reset maintenance period hrs	Yes / No	No
	Maintenance days	0 to 999 d	365 d
	Reset maintenance period days	Yes / No	No
	Code level for reset maint.	0 to 3	3
	Counter value preset	0 to 99999999	0
	Set operation hours in 0.00h	Yes / No	No
	Counter value preset	0 to 99999999	0
	Gen. active power [0.00MWh]	Yes / No	No
	Counter value preset	0 to 65535	0
	Set number of starts	Yes / No	No

Table 3-118: Application - standard values - configure counters

Configure Counters: Maintenance Call

A maintenance call will be issued if the configured number of maintenance hours has expired or the configured number of days has expired since the last maintenance.

In case of a maintenance call, the display indicates "**Mainten. days exceeded**" or "**Mainten. hours exceeded**".

EN	Maintenance hours
DE	Wartungsintervall Stunden
CL2	{0} {10} {10c} {20c}
2550	✓ ✓ ✓ ✓

Counter: Maintenance interval 'Hours' 0 to 9,999 h

ⓘ To disable the maintenance "hours" counter configure "0" for this entry.

This parameter defines the remaining hours until the next maintenance call occurs. Once the generator has been operated for the number of hours configured here, a maintenance message is displayed.

If the maintenance counter is reset either by the push-buttons at the front panel (refer to manual 37428), or by configuring the parameter "Reset maintenance call" to "Yes" (parameter 2562 on page 268), the maintenance counter is reset to the configured value.

EN	Reset maintenance period hrs
DE	Wartungsstunden rücksetzen
CL2	{0} {10} {10c} {20c}
2562	✓ ✓ ✓ ✓

Counter: Reset maintenance call counter 'Hours' Yes / No

If this parameter is configured to "Yes" the maintenance "hours" counter is reset to the configured value. Once the counter has been reset, the control unit changes this parameter to "No".

Note: When using a specific code level in parameter 2567 for reset of maint. hours this parameter can be blocked.

EN	Maintenance days			
DE	Wartungsintervall Tage			
CL2	{0}	{1o}	{1oc}	{2oc}
2551	✓	✓	✓	✓

Counter: Maintenance interval 'Days' 0 to 999 days

ⓘ To disable the maintenance "days" counter configure "0" for this entry.

This parameter defines the remaining days until the next maintenance call occurs. Once the configured number of days has expired since the last maintenance, a maintenance message is displayed.

If the maintenance counter is reset either by the push-buttons at the front panel (refer to manual 37428), or by configuring the parameter "Reset maintenance call" to "Yes" (parameter 2563 on page 269), the maintenance counter is reset to the configured value.

EN	Reset maintenance period days			
DE	Wartungstage rücksetzen			
CL2	{0}	{1o}	{1oc}	{2oc}
2563	✓	✓	✓	✓

Counter: Reset maintenance call counter 'Days' Yes / No

If this parameter is configured to "Yes" the maintenance "days" counter is reset to the configured value. Once the counter has been reset, the control unit changes this parameter to "No".

Note: When using a specific code level in parameter 2567 for reset of maint. days this parameter can be blocked.

EN	Code level for reset maint.			
DE	Codeebene für Wartung rückset.			
CL2	{0}	{1o}	{1oc}	{2oc}
2567	✓	✓	✓	✓

Counter: Code level for resetting the maintenance call 0 to 3

This parameter determines the required code level for resetting the counter "Maintenance call in...". User with a lower code level may not access this function. The following code levels exist:

- 3 = Commissioner
- 2 = Temporary commissioner
- 1 = Service level
- 0 = Operator

Configure Counters: Operation Hours, kWh, and kvarh

EN	Counter value preset			
DE	Zähler-Setzwert			
CL2	{0}	{1o}	{1oc}	{2oc}
2515	✓	✓	✓	✓

Counter: Set point value for counters 0 to 99,999,999

This value is utilized to set the following counters:

- operation hours counter
- kWh counter
- kvarh counter

The number entered into this parameter is the number that will be set to the parameters listed above when they are enabled.

EN	Set operation hours in 0.00h			
DE	Betriebsstd. setzen in 0.00h			
CL2	{0}	{1o}	{1oc}	{2oc}
2574	✓	✓	✓	✓

Counter: Set operation hours counter Yes / No

Yes.....The current value of this counter is overwritten with the value configured in "set point value for counters". After the counter has been (re)set, this parameter changes back to "No" automatically.
No.....The value of this counter is not changed.

EN	Gen. active power [0.00MWh]			
DE	Gen. Wirkarbeit [0,00MWh]			
CL2	{0}	{1o}	{1oc}	{2oc}
2510	✓	✓	✓	✓

Counter: Set kWh counter Yes / No

Yes.....The current value of this counter is overwritten with the value configured in "set point value for counters". After the counter has been (re)set, this parameter changes back to "No" automatically.
No.....The value of this counter is not changed.



NOTE

Example: The counter value preset (parameter 2515 on page 269) is configured to "3456".
 If parameter 2574 will be configured to Yes, the operation hour counter will be set to 3456h.
 If parameter 2510 will be configured to Yes, the active energy counter will be set to 34.56MWh.

Configure Counters: Start Counter

EN	Counter value preset	Counter: Set point value for start counter	0 to 65535
----	-----------------------------	---	-------------------

DE	Zähler-Setzwert		
----	------------------------	--	--

CL2	{0}	{1o}	{1oc}	{2oc}	
2541	✓	✓	✓	✓	

This parameter defines the number of times the control unit registers a start of the generator set. The number entered here will overwrite the current displayed value after confirming with parameter 2542 on page 270.

EN	Set number of starts	Counter: Set start counter	Yes / No
----	-----------------------------	-----------------------------------	-----------------

DE	Anzahl Starts setzen		
----	-----------------------------	--	--

CL2	{0}	{1o}	{1oc}	{2oc}	
2542	✓	✓	✓	✓	

Yes.....The current value of the start counter is overwritten with the value configured in "Set point value for start counter". After the counter has been (re)set, this parameter changes back to "No" automatically.

No.....The value of this counter is not changed..

Configure Counters: Operation Hours

EN	Operation hours source	Counter: Operation hours source	Internal / ECU/J1939
----	-------------------------------	--	-----------------------------

DE	Quelle Betriebsstunden		
----	-------------------------------	--	--

CL2	{0}	{1o}	{1oc}	{2oc}	
15154	✓	✓	✓	✓	

This parameter configures the source for the operation hours.

Internal.....The operation hours are counted internal from the easYgen
ECU/J1939 ..The operation hours are assumed from the connected ECU (via J1939 CAN protocol).

Appendix A. Miscellaneous

Alarm Classes

The control functions are structured in the following alarm classes:

Alarm class	Visible in the display	LED "Alarm" & horn	Relay "Command: open GCB"	Shut-down engine	Engine blocked until ack. sequence has been performed
A	yes Warning Alarm This alarm does not interrupt the unit operation. A message output without a centralized alarm occurs: ⇒ Alarm text.	no	no	no	no
B	yes Warning Alarm This alarm does not interrupt the unit operation. An output of the centralized alarm occurs and the command variable 3.05 (horn) is issued. ⇒ Alarm text + flashing LED "Alarm" + Relay centralized alarm (horn).	yes	no	no	no
C	yes Shutdown Alarm With this alarm the GCB is opened and the engine is stopped. Coasting occurs. ⇒ Alarm text + flashing LED "Alarm" + Relay centralized alarm (horn) + GCB open + Coasting + Engine stop.	yes	soft unloading	cool down time	yes
D	yes Shutdown Alarm With this alarm the GCB is opened and the engine is stopped. Coasting occurs. ⇒ Alarm text + flashing LED "Alarm" + Relay centralized alarm (horn) + GCB open + Coasting + Engine stop.	yes	immediately	cool down time	yes
E	yes Shutdown Alarm With this alarm the GCB is opened immediately and the engine is stopped. ⇒ Alarm text + flashing LED "Alarm" + Relay centralized alarm (horn)+ GCB open + Engine stop.	yes	soft unloading	immediately	yes
F	yes Shutdown Alarm With this alarm the GCB is opened immediately and the engine is stopped. ⇒ Alarm text + flashing LED "Alarm" + Relay centralized alarm (horn)+ GCB open + Engine stop.	yes	immediately	immediately	yes
Control	no Control Signal This signal issues a control command only. It may be assigned to a discrete input for example to get a control signal, which may be used in the <i>LogicsManager</i> . No alarm message and no entry in the alarm list or the event history will be issued. This signal is always self-acknowledging, but considers a delay time and may also be configured with an engine delay.	no	no	no	no



CAUTION

If an alarm of class C, D, or E is present and the GCB cannot be opened, the engine will not be stopped. This can only be achieved by enabling GCB monitoring (parameter 2600 on page 116) with the alarm class configured to "F" (parameter 2601 on page 116).



NOTE

If an alarm has been configured with a shutdown alarm that has been enabled to self-acknowledge, and has been configured as engine delayed the following scenario may happen:

- The alarm shuts down the engine because of its alarm class.
- Due to the engine stopping, all engine delayed alarms are ignored.
- The alarm class is acknowledged automatically.
- The alarm will self-acknowledge and clear the fault message that shut the engine down. This prevents the fault from being analyzed. After a short delay, the engine will restart.
- After the engine monitoring delay expires, the fault that originally shut down the engine will do so again. This cycle will continue to repeat until corrected.

Conversion Factors



Temperature

$^{\circ}\text{C} \Rightarrow ^{\circ}\text{F}$	$^{\circ}\text{F} \Rightarrow ^{\circ}\text{C}$
$T [^{\circ}\text{F}] = (T [^{\circ}\text{C}] \times 1.8) + 32$	$T [^{\circ}\text{C}] = (T [^{\circ}\text{F}] - 32) / 1.8$

Pressure

$\text{bar} \Rightarrow \text{psi}$	$\text{psi} \Rightarrow \text{bar}$
$P [\text{psi}] = P [\text{bar}] \times 14.503$	$P [\text{bar}] = P [\text{psi}] / 14.503$

Appendix B.

LogicsManager

The *LogicsManager* is used to customize the sequence of events in the control **unit** such as the start command of the engine or the operation of control unit relay outputs. For example, the start routine may be programmed so that it requires the closing of a discrete input or a preset time of day. Depending on the application mode of the unit, the number of available relays that may be programmed with the *LogicsManager* will vary. Two independent time delays are provided for the configured action to take place and be reset.

Structure and Description of the *LogicsManager*

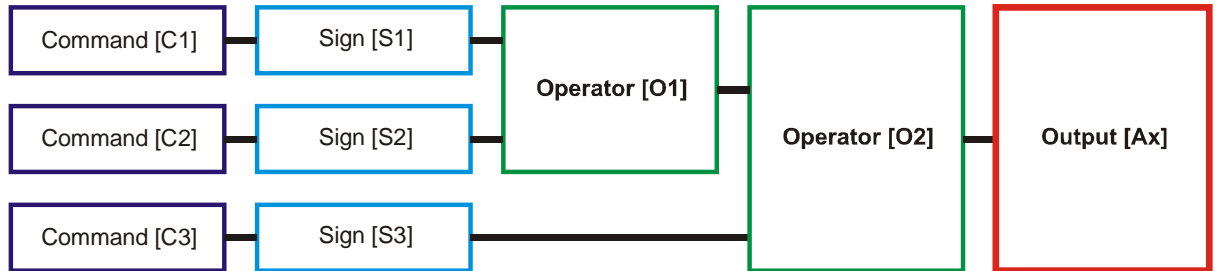

Figure 3-32: *LogicsManager* - function overview

- **Command (variable)** - A list of over 400 parameters and functions is provided for the command inputs. Examples of the parameters that may be configured into these commands are generator undervoltage thresholds 1 and 2, start fail, and cool down. These command variables are used to control the output function or relay. Refer to Logical Command Variables starting on page 279 for a complete list of all command variables.
- **Sign** - The sign field can be used to invert the state of the command or to fix its output to a logical true or false if the command is not needed. Setting the sign to the NOT state changes the output of the command variable from true to false or vice versa.
- **Operator** - A logical device such as AND or OR.
- **(Logical) output** - The action or control sequence that occurs when all parameters set into the *LogicsManager* are met.

[Cx] - Command {x}	[Sx] - Sign {x}	[Ox] - Operator {x}	[Ax] - Output {x}
<p>The description and the tables of all values, flags, and internal functions that are able to combine via the <i>LogicsManager</i> can be found in the Logical Command Variables section starting on page 279.</p>	<p>Value {[Cx]} The value [Cx] is passed 1:1.</p> <p style="text-align: center;">—</p> <p>NOT Value {[Cx]} The opposite of the value [Cx] is passed.</p> <p style="text-align: center;">1 </p> <p>0 [False; always "0"] The value [Cx] is ignored and this logic path will always be FALSE.</p> <p style="text-align: center;">"0" </p> <p>1 [True; always "1"] The value [Cx] is ignored and this logic path will always be TRUE.</p> <p style="text-align: center;">"1" </p>	<p style="text-align: center;">AND Logical AND</p> <p style="text-align: center;">NAND Logical negated AND</p> <p style="text-align: center;">OR Logical OR</p> <p style="text-align: center;">NOR Logical negated OR</p> <p style="text-align: center;">XOR Exclusive OR</p> <p style="text-align: center;">NXOR Exclusive negated OR</p> <p style="text-align: center;">(See Table 3-120 for symbols)</p>	<p>The description and the tables of all logical outputs, flags, and functions that are able to combine via the <i>LogicsManager</i> can be found in the Logical Outputs section starting on page 275.</p>

Table 3-119: *LogicsManager* - command overview

Configuration of the Command Chain

Using the values specified in the above table, the chain of commands of the *LogicsManager* (for example: operating the relays, setting the flags, specification of the automatic functions) is configured as follows:

$$[Ax] = (([C1] \& [S1]) \& [O1] \& ([C2] \& [S2])) \& [O2] \& ([C3] \& [S3])$$

Programming example for the *LogicsManager*:

Relay [R2] shall energize, whenever "Discrete input [D2]" is energized "AND" the control does "NOT" have a fault that is "Alarm class C" "AND" does "NOT" have a fault that is "Alarm class D" ⇒

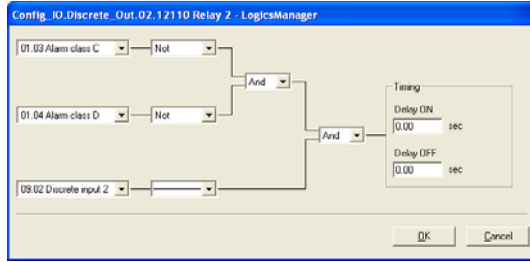

Figure 3-33: *LogicsManager* - display in ToolKit



Figure 3-34: *LogicsManager* - display on LCD screen

Logical Symbols



The following symbols are used for the graphical programming of the *LogicsManager*. The easYgen displays symbols according to the IEC standard by default. It is possible to change to ASA standard display using parameter 4117 on page 265.

ToolKit	AND	OR	NAND	NOR	NXOR	XOR																																																																																										
easYgen (default)																																																																																																
DIN 40 700																																																																																																
ASA US MIL (configurable)																																																																																																
IEC617-12																																																																																																
Truth table	<table border="1"> <tr><th>x1</th><th>x2</th><th>y</th></tr> <tr><td>0</td><td>0</td><td>0</td></tr> <tr><td>0</td><td>1</td><td>0</td></tr> <tr><td>1</td><td>0</td><td>0</td></tr> <tr><td>1</td><td>1</td><td>1</td></tr> </table>	x1	x2	y	0	0	0	0	1	0	1	0	0	1	1	1	<table border="1"> <tr><th>x1</th><th>x2</th><th>y</th></tr> <tr><td>0</td><td>0</td><td>0</td></tr> <tr><td>0</td><td>1</td><td>1</td></tr> <tr><td>1</td><td>0</td><td>1</td></tr> <tr><td>1</td><td>1</td><td>1</td></tr> </table>	x1	x2	y	0	0	0	0	1	1	1	0	1	1	1	1	<table border="1"> <tr><th>x1</th><th>x2</th><th>y</th></tr> <tr><td>0</td><td>0</td><td>1</td></tr> <tr><td>0</td><td>1</td><td>1</td></tr> <tr><td>1</td><td>0</td><td>1</td></tr> <tr><td>1</td><td>1</td><td>0</td></tr> </table>	x1	x2	y	0	0	1	0	1	1	1	0	1	1	1	0	<table border="1"> <tr><th>x1</th><th>x2</th><th>y</th></tr> <tr><td>0</td><td>0</td><td>1</td></tr> <tr><td>0</td><td>1</td><td>0</td></tr> <tr><td>1</td><td>0</td><td>0</td></tr> <tr><td>1</td><td>1</td><td>0</td></tr> </table>	x1	x2	y	0	0	1	0	1	0	1	0	0	1	1	0	<table border="1"> <tr><th>x1</th><th>x2</th><th>y</th></tr> <tr><td>0</td><td>0</td><td>1</td></tr> <tr><td>0</td><td>1</td><td>0</td></tr> <tr><td>1</td><td>0</td><td>0</td></tr> <tr><td>1</td><td>1</td><td>1</td></tr> </table>	x1	x2	y	0	0	1	0	1	0	1	0	0	1	1	1	<table border="1"> <tr><th>x1</th><th>x2</th><th>y</th></tr> <tr><td>0</td><td>0</td><td>0</td></tr> <tr><td>0</td><td>1</td><td>1</td></tr> <tr><td>1</td><td>0</td><td>1</td></tr> <tr><td>1</td><td>1</td><td>0</td></tr> </table>	x1	x2	y	0	0	0	0	1	1	1	0	1	1	1	0
x1	x2	y																																																																																														
0	0	0																																																																																														
0	1	0																																																																																														
1	0	0																																																																																														
1	1	1																																																																																														
x1	x2	y																																																																																														
0	0	0																																																																																														
0	1	1																																																																																														
1	0	1																																																																																														
1	1	1																																																																																														
x1	x2	y																																																																																														
0	0	1																																																																																														
0	1	1																																																																																														
1	0	1																																																																																														
1	1	0																																																																																														
x1	x2	y																																																																																														
0	0	1																																																																																														
0	1	0																																																																																														
1	0	0																																																																																														
1	1	0																																																																																														
x1	x2	y																																																																																														
0	0	1																																																																																														
0	1	0																																																																																														
1	0	0																																																																																														
1	1	1																																																																																														
x1	x2	y																																																																																														
0	0	0																																																																																														
0	1	1																																																																																														
1	0	1																																																																																														
1	1	0																																																																																														

Table 3-120: *LogicsManager* - logical symbols

Logical Outputs



The logical outputs or combinations may be grouped into three categories:

- Internal logical flags
- Internal functions
- Relay outputs



NOTE

The numbers of the logical outputs in the third column may again be used as input variable for other outputs in the *LogicsManager*.

Logical Outputs: Internal Flags

16 internal logical flags may be programmed to activate/deactivate functions. This permits more than 3 commands to be included in a logical function. They may be used like "auxiliary flags".

Name	Function	Number
Flag 1	Internal flag 1	00.01
Flag 2	Internal flag 2	00.02
Flag 3	Internal flag 3	00.03
Flag 4	Internal flag 4	00.04
Flag 5	Internal flag 5	00.05
Flag 6	Internal flag 6	00.06
Flag 7	Internal flag 7	00.07
Flag 8	Internal flag 8	00.08
Flag 9	Internal flag 9	00.30
Flag 10	Internal flag 10	00.31
Flag 11	Internal flag 11	00.32
Flag 12	Internal flag 12	00.33
Flag 13	Internal flag 13	00.34
Flag 14	Internal flag 14	00.35
Flag 15	Internal flag 15	00.36
Flag 16	Internal flag 16	00.37

Logical Outputs: Internal Functions

The following logical functions may be used to activate/deactivate functions.

Name	Function	Number
Start request in AUTO	Start in AUTOMATIC operating mode (parameter 12120 on page 193)	00.09
Stop request in AUTO	Stop in AUTOMATIC operating mode (parameter 12190 on page 194)	00.10
Inhibit emergency run	Blocking or interruption of an emergency power operating in AUTOMATIC operating mode (parameter 12200 on page 192)	00.11
Undelay close GCB	Immediately closing of the GCB after engine start without waiting for the engine delayed monitoring and generator stable timer to expire (parameter 12210 on page 153)	00.12
Constant idle run	Enables idle/rated speed modes (parameter 12550 on page 190).	00.14
External acknowledge	The alarm acknowledgement is performed from an external source (parameter 12490 on page 126)	00.15
Operation mode AUTO	Activation of the AUTOMATIC operating mode (parameter 12510 on page 211)	00.16
Operation mode MAN	Activation of the MANUAL operating mode (parameter 12520 on page 211)	00.17
Operation mode STOP	Activation of the STOP operating mode (parameter 12530 on page 211)	00.18
Start without load	Starting the engine without closing the GCB (parameter 12540 on page 211)	00.19
Automatic idle mode	Automatic idle mode (blocks the undervoltage, underfrequency, and underspeed monitoring for a configured time automatically, parameter 12570 on page 190)	00.20
Discrete f/P +	Raise frequency / real power set point (parameter 12900 on page 247)	00.21
Discrete f/P -	Lower frequency / real power set point (parameter 12901 on page 247)	00.22
Discrete V/PF +	Raise voltage / power factor set point (parameter 12902 on page 247)	00.23
Discrete V/PF -	Lower voltage / power factor set point (parameter 12903 on page 247)	00.24
Freq. Droop active	Activation of the frequency droop (parameter 12904 on page 223)	00.25
Volt. Droop active	Activation of the voltage droop (parameter 12905 on page 235)	00.26
Critical mode	Activation of critical mode operation (parameter 12220 on page 216)	00.28
Firing speed	Firing (ignition) speed is reached (parameter 12500 on page 186)	00.29
Frequency setpoint 2	Activates the frequency set point 2 (parameter 12918 on page 222)	00.81
Load setpoint 2	Activates the load set point 2 (parameter 12919 on page 228)	00.82
Voltage setpoint 2	Activates the voltage set point 2 (parameter 12920 on page 234)	00.83
Power factor setpoint 2	Activates the power factor set point 2 (parameter 12921 on page 239)	00.84
Enable MCB	Enables the MCB (parameter 12923 on page 157)	00.85
Load-dependent start/stop	Activation of load-dependent start/stop (parameter 12930 on page 198)	00.86
Segment no.2 act	Assigns the genset to load share segm. #2 (parameter 12929 on page 246)	00.87
LDSS Priority 2	Sets the LDSS priority to 2 (parameter 12926 on page 199)	00.90
LDSS Priority 3	Sets the LDSS priority to 3 (parameter 12925 on page 199)	00.91
LDSS Priority 4	Sets the LDSS priority to 4 (parameter 12924 on page 199)	00.92
Transition mode 1	Activates breaker transition mode 1 (parameter 12931 on page 145)	00.93

Priority Hierarchy of the Logical Outputs

The following table contains the priority relationships between the start conditions of the logical outputs in the *LogicsManager*:

Prioritized function	overrides	Reaction
Critical mode	Stop req. in Auto	A start will still be performed.
	Start req. in Auto	The behavior of the system depends on the configuration of the related parameters.
Stop req. in Auto	Start req. in Auto	No start will be performed.
	Emergency power	No start will be performed.
	Idle mode	No start will be performed.
Start w/o load	Start req. in Auto	The GCB remains open / will be opened.
Emergency power	Start w/o load	The GCB will be closed nevertheless.
	Critical mode	The GCB will be closed nevertheless. The alarm class management is still performed like for the critical mode. If emergency power is already enabled and the critical mode will be enabled then, a pause time may be configured for the emergency power operation.
Inhibit emergency run	Emergency power	No start will be performed.
	Emergency power during Start w/o load	The generator keeps on running without taking over load.

Logical Outputs: Relay Outputs

All relays may be controlled directly by the *LogicsManager* depending on the respective application mode.

Name	Function	Number
Relay 1 (Ready for operation OFF)	If this logical output becomes true, the relay output 1 will be activated	00.41
Relay 2	If this logical output becomes true, the relay output 2 will be activated	00.42
Relay 3	If this logical output becomes true, the relay output 3 will be activated	00.43
Relay 4	If this logical output becomes true, the relay output 4 will be activated	00.44
Relay 5	If this logical output becomes true, the relay output 5 will be activated	00.45
Relay 6	If this logical output becomes true, the relay output 6 will be activated	00.46
Relay 7	If this logical output becomes true, the relay output 7 will be activated	00.47
Relay 8	If this logical output becomes true, the relay output 8 will be activated	00.48
Relay 9	If this logical output becomes true, the relay output 9 will be activated	00.49
Relay 10	If this logical output becomes true, the relay output 10 will be activated	00.50
Relay 11	If this logical output becomes true, the relay output 11 will be activated	00.51
External DO 1	If this logical output becomes true, the external relay output 1 will be activated	00.63
External DO 2	If this logical output becomes true, the external relay output 2 will be activated	00.64
External DO 3	If this logical output becomes true, the external relay output 3 will be activated	00.65
External DO 4	If this logical output becomes true, the external relay output 4 will be activated	00.66
External DO 5	If this logical output becomes true, the external relay output 5 will be activated	00.67
External DO 6	If this logical output becomes true, the external relay output 6 will be activated	00.68
External DO 7	If this logical output becomes true, the external relay output 7 will be activated	00.69
External DO 8	If this logical output becomes true, the external relay output 8 will be activated	00.70
External DO 9	If this logical output becomes true, the external relay output 9 will be activated	00.71
External DO 10	If this logical output becomes true, the external relay output 10 will be activated	00.72
External DO 11	If this logical output becomes true, the external relay output 11 will be activated	00.73
External DO 12	If this logical output becomes true, the external relay output 12 will be activated	00.74
External DO 13	If this logical output becomes true, the external relay output 13 will be activated	00.75
External DO 14	If this logical output becomes true, the external relay output 14 will be activated	00.76
External DO 15	If this logical output becomes true, the external relay output 15 will be activated	00.77
External DO 16	If this logical output becomes true, the external relay output 16 will be activated	00.78

Table 3-119 shows the function of each relay in each of the application modes.

Relay Number	Term.	Application mode (parameter 3401 on page 141)			
		None {0}	GCB open {1o}	GCB open/close {1oc}	GCB/MCB open/close {2oc}
Internal relay outputs					
[R1]	30/31	<i>LogicsManager</i> ; pre-assigned with 'Ready for operation OFF'			
[R2]	32/33	<i>LogicsManager</i> ; pre-assigned with 'Centralized alarm (horn)'			
[R3]	34/35	<i>LogicsManager</i> ; pre-assigned with 'Starter'			
[R4]	36/37	<i>LogicsManager</i> ; pre-assigned with 'Diesel: Fuel solenoid, Gas: Gas valve'			
[R5]	38/39/40	<i>LogicsManager</i> ; pre-assigned with 'Warning alarm'			Command: open MCB
[R6]	41/42	<i>LogicsManager</i>		Command: close GCB	
[R7]	80/81	<i>LogicsManager</i>	Command: open GCB		
[R8]	82/83	<i>LogicsManager</i> ; pre-assigned with 'Mains decoupling'			Command: close MCB
[R9]	84/85	<i>LogicsManager</i> ; pre-assigned with 'Stop solenoid'			
[R10]	86/87	<i>LogicsManager</i> ; pre-assigned with 'Auxiliary services'			
[R11]	88/89	<i>LogicsManager</i> ; pre-assigned with 'Shut down alarm'			

Table 3-121: Relay outputs - terminal assignment

Logical Command Variables



The logical command variables are grouped into different categories:

- Group 00: Flags condition 1
- Group 01: Alarm system
- Group 02: Systems condition
- Group 03: Engine control
- Group 04: Applications condition
- Group 05: Engine related alarms
- Group 06: Generator related alarms
- Group 07: Mains related alarms
- Group 08: System related alarms
- Group 09: Discrete inputs
- Group 10: Analog inputs
- Group 11: Clock and timer
- Group 12: External DIs 1
- Group 13: Discrete outputs
- Group 14: External DOs 1
- Group 15: Flexible limits
- Group 18: Transistor outputs

Logical Command Variables: Group 00: Flags Condition 1

Flags condition 1, Logic command variables 00.01-00.94

Internal Flags are the result of the output of the logic ladders from Flag 1 to 16. Flags are internal logic that can be sent to other flags or Command variables.

No.	ID	Name	Function	Note
00.01	0	LM: Flag 1	Internal flag 1	Internal calculation; descr. page 275
00.02	1	LM: Flag 2	Internal flag 2	Internal calculation; descr. page 275
00.03	2	LM: Flag 3	Internal flag 3	Internal calculation; descr. page 275
00.04	3	LM: Flag 4	Internal flag 4	Internal calculation; descr. page 275
00.05	4	LM: Flag 5	Internal flag 5	Internal calculation; descr. page 275
00.06	5	LM: Flag 6	Internal flag 6	Internal calculation; descr. page 275
00.07	6	LM: Flag 7	Internal flag 7	Internal calculation; descr. page 275
00.08	7	LM: Flag 8	Internal flag 8	Internal calculation; descr. page 275
00.09	8	LM: Start request in AUTO	Start in AUTOMATIC operating mode	Internal calculation; descr. page 194
00.10	9	LM: Stop request in AUTO	Stop in AUTOMATIC operating mode	Internal calculation; descr. page 194
00.11	10	LM: Inhibit emergency run	Blocking or interruption of an emergency power operation in AUTOMATIC operating mode	Internal calculation; descr. page 192
00.12	11	LM: Undelay close GCB	Immediately closing of the GCB without waiting for the engine delayed monitoring timer to expire	Internal calculation; descr. page 153
00.14	13	LM: Constant idle run	Constant idle speed mode enabled (blocks alarm for undervoltage, underfrequency, and underspeed constantly)	Internal calculation; descr. page 190
00.15	14	LM: External acknowledge	The alarm acknowledgement is performed from an external source	Internal calculation; descr. page 126
00.16	15	LM: Operation mode AUTO	Activation of the AUTOMATIC operating mode	Internal calculation; descr. page 211
00.17	16	LM: Operation mode MAN	Activation of the MANUAL op. mode	Internal calculation; descr. page 211
00.18	17	LM: Operation mode STOP	Activation of the STOP operating mode	Internal calculation; descr. page 211
00.19	18	LM: Start w/o load	Starting the engine without closing the GCB	Internal calculation; descr. page 211
00.20	19	LM: Automatic idle mode	Automatic idle speed mode (blocks alarm for undervoltage, underfrequency, and underspeed automatically for a set time)	Internal calculation; descr. page 190
00.21	20	LM: Discrete f/P +	Raise frequency / real power set point	Internal calculation; descr. page 247
00.22	21	LM: Discrete f/P -	Lower frequency / real power set point	Internal calculation; descr. page 247
00.23	22	LM: Discrete V/PF +	Raise voltage / power factor set point	Internal calculation; descr. page 247
00.24	23	LM: Discrete V/PF -	Lower voltage / power factor set point	Internal calculation; descr. page 247
00.25	24	LM: Freq. Droop active	Frequency droop active	Internal calculation; descr. page 223
00.26	25	LM: Volt. Droop active	Voltage droop active	Internal calculation; descr. page 235
00.28	27	LM: Critical mode	Activation of critical mode operation	Internal calculation; descr. page 212
00.29	28	LM: Firing speed	Firing (ignition) speed is reached.	Internal calculation; descr. page 185
00.30	29	LM: Flag 9	Internal flag 9	Internal calculation; descr. page 275
00.31	30	LM: Flag 10	Internal flag 10	Internal calculation; descr. page 275
00.32	31	LM: Flag 11	Internal flag 11	Internal calculation; descr. page 275
00.33	32	LM: Flag 12	Internal flag 12	Internal calculation; descr. page 275
00.34	33	LM: Flag 13	Internal flag 13	Internal calculation; descr. page 275
00.35	34	LM: Flag 14	Internal flag 14	Internal calculation; descr. page 275
00.36	35	LM: Flag 15	Internal flag 15	Internal calculation; descr. page 275
00.37	36	LM: Flag 16	Internal flag 16	Internal calculation; descr. page 275

No.	ID	Name	Function	Note
00.41	40	LM: Relay 1		TRUE, if the <i>LogicsManager</i> condition driving this relay is fulfilled; refer to page 172 for more information
00.42	41	LM: Relay 2		
00.43	42	LM: Relay 3		
00.44	43	LM: Relay 4		
00.45	44	LM: Relay 5		
00.46	45	LM: Relay 6		
00.47	46	LM: Relay 7		
00.48	47	LM: Relay 8		
00.49	48	LM: Relay 9		
00.50	49	LM: Relay 10		
00.51	50	LM: Relay 11		
00.63	62	LM: External relay DO 1		TRUE, if the <i>LogicsManager</i> condition driving this relay is fulfilled; refer to page 173 for more information
00.64	63	LM: External relay DO 2		
00.65	64	LM: External relay DO 3		
00.66	65	LM: External relay DO 4		
00.67	66	LM: External relay DO 5		
00.68	67	LM: External relay DO 6		
00.69	68	LM: External relay DO 7		
00.70	69	LM: External relay DO 8		
00.71	70	LM: External relay DO 9		
00.72	71	LM: External relay DO 10		
00.73	72	LM: External relay DO 11		
00.74	73	LM: External relay DO 12		
00.75	74	LM: External relay DO 13		
00.76	75	LM: External relay DO 14		
00.77	76	LM: External relay DO 15		
00.78	77	LM: External relay DO 16		
00.81	80	LM: Setpoint 2 frequency	Activation of frequency set point 2	Internal calculation; descr. page 222
00.82	81	LM: Setpoint 2 load	Activation of load set point 2	Internal calculation; descr. page 228
00.83	82	LM: Setpoint 2 voltage	Activation of voltage set point 2	Internal calculation; descr. page 234
00.84	83	LM: Setpoint 2 power factor	Activation of power factor set point 2	Internal calculation; descr. page 239
00.85	84	LM: Enable MCB	MCB is enabled	Internal calculation; descr. page 157
00.86	85	LM: LD start/stop	Activation of load-dependent start/stop	Internal calculation; descr. page 195
00.87	86	LM: Segment no.2 act	Assigns the genset to load share segm. 2	Internal calculation; descr. page 246
00.90	89	LM: LDSS Priority 2	Sets the LDSS priority to 2	Internal calculation; descr. page 199
00.91	90	LM: LDSS Priority 3	Sets the LDSS priority to 3	Internal calculation; descr. page 199
00.92	91	LM: LDSS Priority 4	Sets the LDSS priority to 4	Internal calculation; descr. page 199
00.93	92	LM: Transition mode 1	Activates breaker transition mode 1	Internal calculation; descr. page 145

Logical Command Variables: Group 01: Alarm System

Alarm system, Logic command variables 01.01-01.11

Alarm classes may be configured as command variables for all logical outputs in the *LogicsManager*. Refer to page 271 for a description of the alarm classes.

No.	ID	Name / Function	Note
01.01	99	Alarm class A	TRUE as long as an alarm of this alarm class is active or latched (triggered)
01.02	100	Alarm class B	TRUE as long as an alarm of this alarm class is active or latched (triggered)
01.03	101	Alarm class C	TRUE as long as an alarm of this alarm class is active or latched (triggered)
01.04	102	Alarm class D	TRUE as long as an alarm of this alarm class is active or latched (triggered)
01.05	103	Alarm class E	TRUE as long as an alarm of this alarm class is active or latched (triggered)
01.06	104	Alarm class F	TRUE as long as an alarm of this alarm class is active or latched (triggered)
01.07	105	All alarm classes	TRUE as long as at least one alarm of the alarm classes A/B/C/D/E/F is active or latched (triggered)
01.08	106	Warning alarm	TRUE as long as at least one alarm of the alarm classes A/B is active or latched (triggered)
01.09	107	Shutdown alarm	TRUE as long as at least one alarm of the alarm classes C/D/E/F is active or latched (triggered)
01.10	108	Centralized alarm	TRUE as long as at least one alarm of the alarm classes B/C/D/E/F is active or latched (triggered)
01.11	109	New alarm triggered	TRUE if any alarm has been triggered until it is acknowledged

Logical Command Variables: Group 02: Systems Condition

Systems condition, Logic command variables 02.01-02.22

The status of the system may be used as command variable in a logical output to set parameters for customized operations.

No.	ID	Name	Function	Note
02.01	119	Firing speed detected	Firing speed recognized (via MPU/gen. frequency / <i>LogicsManager</i>)	TRUE as long as at least firing speed is measured (defined by parameter 3313 on page 186) either via the MPU or the generator frequency; or is detected via the <i>LogicsManager</i> output "ignition speed reached" (defined by parameters 3324 and 12500 on page 186)
02.02	120	Speed detected	Speed recognized (via MPU/gen. frequency / <i>LogicsManager</i>)	TRUE as long as a speed is measured (this can be lower than the ignition speed; either via the MPU, the generator frequency, or the <i>LogicsManager</i> output "ignition speed reached")
02.03	121	Generator voltage ok	Generator voltage within operating window	TRUE as long as the generator voltage is within the operating window
02.04	122	Generator frequency ok	Generator frequency within operating window	TRUE as long as the generator frequency is within the operating window
02.05	123	Generator ok	Generator voltage and frequency within operating windows	TRUE as long as the generator voltage and frequency are within the operating windows (02.03. and 02.04 are TRUE)
02.09	127	Mains voltage ok	Mains voltage within operating window	TRUE as long as the mains voltage is within the operating window
02.10	128	Mains frequency ok	Mains frequency within operating window	TRUE as long as the mains frequency is within the operating window
02.11	129	Mains ok	Mains voltage and frequency within operating windows	TRUE as long as the mains voltage and frequency are within the operating windows (02.09. and 02.10 are TRUE)
02.12	130	Generator rotation CCW	Generator voltage: rotating direction CCW	TRUE as long as the respective rotation field is detected in case of a three-phase voltage measurement at the respective measuring location
02.13	131	Generator rotation CW	Generator voltage: rotating direction CW	
02.14	132	Mains rotation CCW	Mains voltage: rotating direction CCW	
02.15	133	Mains rotation CW	Mains voltage: rotating direction CW	
02.21	139	Busbar 1 is dead	Busbar 1 is dead	TRUE as long as the busbar voltage is below the value configured in parameter 5820 (Dead bus detection max. volt.)

Logical Command Variables: Group 03: Engine Control

Engine control, Logic command variables 03.01-03.37

These variables may be used as command variable in a logical output to set parameters for customized operations.

No.	ID	Name / Function	Note
03.01	179	Auxiliary services	TRUE if an auxiliary services prerun or postrun is enabled
03.02	180	Starter	TRUE if the starter relay is energized
03.04	182	Preglow (Diesel) Ignition (Gas)	TRUE if the preglow (Diesel) or ignition (gas) relay is energized
03.05	183	Horn (active)	TRUE if alarm class B to F is activated until the time until horn reset is expired or it is acknowledged for the first time.
03.06	184	Engine released	TRUE if the engine is requested and the start is released
03.07	185	Engine delay over (engine delayed monitoring expired)	TRUE after expiration of the "delayed engine monitoring" timer until the fuel relay is de-energized
03.08	186	Breaker delay over (engine delayed monitoring expired)	TRUE after expiration of the "breaker delay" timer until the fuel relay is de-energized (= CB may be closed)
03.13	191	Blinking lamp ECU	TRUE as soon as the ECU activates the diagnosis light (only for Scania S6 ECU). This command variable is only active if remote control of the ECU via easYgen is activated.
03.14	192	ECU special ignition	TRUE as long as a reset or read-out of the Scania S6 ECU blink code is requested (only for S6 Scania ECU). This command variable is only active if remote control of the ECU via easYgen is activated.
03.20	198	Three-position controller output: frequency / active power (governor) raise	TRUE if the respective three-position controller issues the respective control pulse
03.21	199	Three-position controller output: frequency / active power (governor) lower	
03.22	200	Three-position controller output: voltage / reactive power (AVR) raise	
03.23	201	Three-position controller output: voltage / reactive power (AVR) lower	
03.27	205	Stopping solenoid (Diesel)	TRUE if a stop signal is issued until the stop time of engine expires
03.28	206	Operating solenoid (Diesel) Gas valve (Gas)	TRUE if the fuel solenoid (Diesel) or gas valve (gas) relay is energized
03.30	208	Auxiliary services prerun	TRUE, if "Auxiliary services prerun" is active
03.31	209	Auxiliary services postrun	TRUE, if "Auxiliary services postrun" is active

Logical Command Variables: Group 04: Applications Condition

Applications condition, Logic command variables 4.01-04.60

These operating statuses may be used as command variable in a logical output to set parameters for customized operations.

No.	ID	Name	Function	Note
04.01	239	Auto mode	AUTOMATIC operating mode active	TRUE in AUTOMATIC operating mode
04.02	240	Stop mode	STOP operating mode active	TRUE in STOP operating mode
04.03	241	Manual mode	MANUAL operating mode active	TRUE in MANUAL operating mode
04.04	242	Lamp test	A lamp test is being performed	TRUE if the lamp test is active
04.05	243	Acknowledge	"Acknowledge" push button has been pressed or an external acknowledgment via <i>LogicsManager</i>	This condition is TRUE for approx. 40 ms and must be extended utilizing a delay time
04.06	244	GCB closed	GCB is closed {1oc} and {2oc}	TRUE if DI 8 (Reply GCB) is de-energized
04.07	245	MCB closed	MCB is closed {2oc} only	TRUE if DI 7 (Reply MCB) is de-energized
04.09	247	Emergency mode	Emergency power operation active	TRUE with the expiration of the emergency power delay; FALSE with the expiration of the mains setting time and the reply from the MCB is closed
04.10	248	Cool down	Engine cool-down cycle active	TRUE as long as the cool down time is running
04.11	249	Mains settling	Mains settling time active	Becomes TRUE with a mains failure and FALSE after the mains settling timer has expired
04.12	250	Start w/o load	Start without closing GCB is active	TRUE if Start w/o load is enabled
04.13	251	Remote request	Request over remote control to activate a function	TRUE if the start bit is set via serial connection (Modbus) or CAN bus (CANopen), (control word 503)
04.14	252	Remote acknowledge	Request over remote control to acknowledge	TRUE if this bit is set via interface (control word 503)
04.15	253	Idle run active	Idle mode is active	TRUE if the idle mode is active. This may be used to issue an "Idle" command to a speed controller.
04.18	256	Synchron. GCB active	Synchronization GCB is active	TRUE if the GCB shall be synchronized until the GCB is closed
04.19	257	Opening GCB active	Opening GCB is active	TRUE if a GCB open command is issued until DI 8 (Reply GCB) is energized
04.20	258	Closing GCB active	Closing GCB is active	TRUE if a GCB close command is issued; same function as relay 6 in {1oc} or {2oc}
04.21	259	Syn. MCB is active	Synchronization MCB is active	TRUE if the MCB shall be synchronized until the MCB is closed
04.22	260	Opening MCB active	Opening MCB is active	TRUE if an MCB open command is issued until DI 7 (Reply GCB) is energized
04.23	261	Closing MCB active	Closing MCB is active	TRUE if an MCB close command is issued; same function as relay 8 in {2oc}
04.27	265	Critical mode	Critical mode operation is enabled	TRUE if critical mode is enabled
04.28	266	Generator unloading	Generator unloading sequence is active	TRUE if a stop command has been issued until the GCB is opened
04.29	267	Mains unloading	Mains unloading sequence is active	TRUE if a synchronization has been started until the MCB is opened
04.30	268	Power limited prerun	Prerun operation with power limitation is active	TRUE as long as the warm up load limitation is enabled
04.31	269	Segment no.2 act	Load share group 2 is activated	Internal calculation; descr. page 246

No.	ID	Name	Function	Note
04.34	272	LDSS Priority 2	Load-dependent start/stop priority 2 is activated	Internal calculation; descr. page 199
04.35	273	LDSS Priority 3	Load-dependent start/stop priority 3 is activated	Internal calculation; descr. page 199
04.36	274	LDSS Priority 4	Load-dependent start/stop priority 4 is activated	Internal calculation; descr. page 199
04.37	275	Remote volt. setp. 2	Voltage set point 2 is enabled	TRUE if this bit is set via interface (control word 504)
04.38	276	Remote freq. setp. 2	Frequency set point 2 is enabled	
04.39	277	Remote PF setp. 2	Power factor set point 2 is enabled	
04.40	278	Remote pwr. setp. 2	Load set point 2 is enabled	
04.41	279	Transition mode 1	Breaker transition mode alternative 1	Internal calculation; descr. page 145
04.43	281	LD start/stop	Load-dependent start/stop is activated	Internal calculation; descr. page 198
04.44	282	Interface Control 1	Free control bit 1 is activated	Refer to the Interface Manual 37430
04.45	283	Interface Control 2	Free control bit 2 is activated	
04.46	284	Interface Control 3	Free control bit 3 is activated	
04.47	285	Interface Control 4	Free control bit 4 is activated	
04.48	286	Interface Control 5	Free control bit 5 is activated	
04.49	287	Interface Control 6	Free control bit 6 is activated	
04.50	288	Interface Control 7	Free control bit 7 is activated	
04.51	289	Interface Control 8	Free control bit 8 is activated	
04.52	290	Interface Control 9	Free control bit 9 is activated	
04.53	291	Interface Control 10	Free control bit 10 is activated	
04.54	292	Interface Control 11	Free control bit 11 is activated	
04.55	293	Interface Control 12	Free control bit 12 is activated	
04.56	294	Interface Control 13	Free control bit 13 is activated	
04.57	295	Interface Control 14	Free control bit 14 is activated	
04.58	296	Interface Control 15	Free control bit 15 is activated	
04.59	297	Interface Control 16	Free control bit 16 is activated	
04.60	298	Crit. mode postrun	Critical mode postrun is active	TRUE as long as the critical mode postrun time is running

Logical Command Variables: Group 05: Engine Related Alarms

Engine related alarms, Logic command variables 05.01-05.15

These engine alarms may be used as command variable in a logical output to set parameters for customized operations.

No.	ID	Name / Function	Note
05.01	299	Overspeed (limit) 1	TRUE = alarm latched (triggered) FALSE = alarm acknowledged
05.02	300	Overspeed (limit) 2	
05.03	301	Underspeed (limit) 1	
05.04	302	Underspeed (limit) 2	
05.05	303	Unintended stop	
05.06	304	Engine stop malfunction	
05.07	305	Speed/frequency mismatch	
05.08	306	Start fail	
05.09	307	Maintenance days exceeded	
05.10	308	Maintenance hours exceeded	
05.11	309	Charge alternator low voltage	
05.13	311	Red stop lamp	
05.14	312	Amber warning lamp	
05.15	313	EEProm failure	

Logical Command Variables: Group 06: Generator Related Alarms

Generator related alarms, Logic command variables 06.01-06.31

These generator alarms may be used as command variable in a logical output to set parameters for customized operations.

No.	ID	Name / Function	Note
06.01	339	Generator overfrequency (limit) 1	TRUE = alarm latched (triggered) FALSE = alarm acknowledged
06.02	340	Generator overfrequency (limit) 2	
06.03	341	Generator underfrequency (limit) 1	
06.04	342	Generator underfrequency (limit) 2	
06.05	343	Generator overvoltage (limit) 1	
06.06	344	Generator overvoltage (limit) 2	
06.07	345	Generator undervoltage (limit) 1	
06.08	346	Generator undervoltage (limit) 2	
06.09	347	Generator (definite time) overcurrent (limit)1	
06.10	348	Generator (definite time) overcurrent (limit) 2	
06.11	349	Generator (definite time) overcurrent (limit) 3	
06.12	350	Generator reverse/reduced power (limit) 1	
06.13	351	Generator reverse/reduced power (limit) 2	
06.14	352	Generator overload IOP (limit) 1	
06.15	353	Generator overload IOP (limit) 2	
06.16	354	(Generator) unbalanced load (limit)1	
06.17	355	(Generator) unbalanced load (limit) 2	
06.18	356	Generator (voltage) asymmetry	
06.19	357	Ground fault (limit) 1	
06.20	358	Ground fault (limit) 2	
06.21	359	Generator mismatched phase rotation (rotation field alarm)	
06.22	360	(Generator) inverse time-overcurrent	
06.23	361	Generator overload MOP (limit) 1	
06.24	362	Generator overload MOP (limit) 2	
06.25	363	Generator power factor inductive (limit) 1	
06.26	364	Generator power factor inductive (limit) 2	
06.27	365	Generator power factor capacitive (limit) 1	
06.28	366	Generator power factor capacitive (limit) 2	
06.29	367	Generator active power ramp mismatch	
06.30	368	Generator unloading mismatch	
06.31	369	Out of operating range	

Logical Command Variables: Group 07: Mains Related Alarms

Mains related alarms, Logic command variables 07.01-07.25

These mains alarms may be used as command variable in a logical output to set parameters for customized operations.

No.	ID	Function	Note
07.05	403	Mains mismatched phase rotation (rotation field alarm)	
07.06	404	Mains overfrequency (limit) 1	
07.07	405	Mains overfrequency (limit) 2	
07.08	406	Mains underfrequency (limit) 1	
07.09	407	Mains underfrequency (limit) 2	
07.10	408	Mains overvoltage (limit) 1	
07.11	409	Mains overvoltage (limit) 2	
07.12	410	Mains undervoltage (limit) 1	
07.13	411	Mains undervoltage (limit) 2	
07.14	412	Mains phase shift	
07.16	414	Mains active power mismatch	
07.25	423	Mains decoupling	

Logical Command Variables: Group 08: System Related Alarms

System related alarms, Logic command variables 08.01-08.33

These system alarms may be used as command variable in a logical output n to set parameters for customized operations.

No.	ID	Function	Note
08.01	459	Battery overvoltage (limit) 1	
08.02	460	Battery overvoltage (limit) 2	
08.03	461	Battery undervoltage (limit) 1	
08.04	462	Battery undervoltage (limit) 2	
08.05	463	GCB fail to close	
08.06	464	GCB fail to open	
08.07	465	MCB fail to close	
08.08	466	MCB fail to open	
08.10	468	CAN J1939 communication alarm	TRUE = alarm latched (triggered) FALSE = alarm acknowledged
08.16	474	Parameter alignment	
08.17	475	Missing members	
08.18	476	CANopen Interface 1	
08.19	477	CANopen Interface 2	
08.20	478	CAN bus overload	
08.30	488	Timeout synchronization GCB	
08.31	489	Timeout synchronization MCB	
08.33	491	Generator /busbar / mains phase rotation mismatch	

Logical Command Variables: Group 09: Discrete Inputs

Discrete inputs, Logic command variables 09.01-09.12

The discrete inputs may be used as command variable in a logical output to set parameters for customized operations.

No.	ID	Function	Note
09.01	519	DI 1 (Discrete input [DI 01])	TRUE = logical "1" (delay times and NO/NC parameters are ignored) FALSE = logical "0" (alarm has been acknowledged or immediately after TRUE condition is not present anymore, if Control is configured as alarm class)
09.02	520	DI 2 (Discrete input [DI 02])	
09.03	521	DI 3 (Discrete input [DI 03])	
09.04	522	DI 4 (Discrete input [DI 04])	
09.05	523	DI 5 (Discrete input [DI 05])	
09.06	524	DI 6 (Discrete input [DI 06])	
09.07	525	DI 7 (Discrete input [DI 07])	
09.08	526	DI 8 (Discrete input [DI 08])	
09.09	527	DI 9 (Discrete input [DI 09])	
09.10	528	DI 10 (Discrete input [DI 10])	

Logical Command Variables: Group 10: Analog Inputs

Analog inputs, Logic command variables 10.01-10.03

The analog inputs may be used as command variable in a logical output.

No.	ID	Name / Function	Note
10.01	559	Analog input AI 01 wire break	TRUE = measured value out of range
10.02	560	Analog input AI 02 wire break	FALSE = logical "0" (alarm has been acknowledged, or immediately after TRUE condition is not present anymore, if Control is configured as alarm class)
10.03	561	Analog input AI 03 wire break	
10.04	562	Analog input AI 04 wire break	

Logical Command Variables: Group 11: Clock and Timer

Clock and timer, Logic command variables 11.01-11.10

Time functions may be used as command variable in a logical output.

No.	ID	Name / Function	Note
11.01	579	Timer set point 1 (exceeded)	see page 266
11.02	580	Timer set point 2 (exceeded)	see page 266
11.03	581	Active weekday (equal to setting)	see page 266
11.04	582	Active day (equal to setting)	see page 266
11.05	583	Active hour (equal to setting)	see page 266
11.06	584	Active minute (equal to setting)	see page 266
11.07	585	Active second (equal to setting)	see page 266
11.08	586	Engine (running hours exceeded by) 1 hour	Status changes every operating hour
11.09	587	Engine (running hours exceeded by) 10 hour	Status changes every 10 operating hours
11.10	588	Engine (running hours exceeded by) 100 hour	Status changes every 100 operating hours

Logical Command Variables: Group 12: External Discrete Inputs 1

External discrete inputs 1, Logic command variables 12.01-12.16

Additional discrete inputs from an expansion board (i.e. IKD 1 extension board) may be used as command variable in a logical output.

No.	ID	Name / Function	Note
12.01	609	External discrete input 1 [D.E01]	TRUE = logical "1" (delay times and NO/NC parameters are ignored) FALSE = logical "0" (alarm has been acknowledged, or immediately after TRUE condition is not present anymore, if Control is configured as alarm class)
12.02	610	External discrete input 2 [D.E02]	
12.03	611	External discrete input 3 [D.E03]	
12.04	612	External discrete input 4 [D.E04]	
12.05	613	External discrete input 5 [D.E05]	
12.06	614	External discrete input 6 [D.E06]	
12.07	615	External discrete input 7 [D.E07]	
12.08	616	External discrete input 8 [D.E08]	
12.09	617	External discrete input 9 [D.E09]	
12.10	618	External discrete input 10 [D.E10]	
12.11	619	External discrete input 11 [D.E11]	
12.12	620	External discrete input 12 [D.E12]	
12.13	621	External discrete input 13 [D.E13]	
12.14	622	External discrete input 14 [D.E14]	
12.15	623	External discrete input 15 [D.E15]	
12.16	624	External discrete input 16 [D.E16]	

Logical Command Variables: Group 13: Discrete Outputs

Discrete outputs, Logic command variables 13.01-13.12

The discrete outputs may be used as command variable in a logical output.

No.	ID	Name / Function	Note
13.01	629	Discrete output DO1 [R01]	TRUE = logical "1" (this condition indicates the logical status of the internal relays) FALSE = logical "0" (this condition indicates the logical status of the internal relays)
13.02	630	Discrete output DO2 [R02]	
13.03	631	Discrete output DO3 [R03]	
13.04	632	Discrete output DO4 [R04]	
13.05	633	Discrete output DO5 [R05]	
13.06	634	Discrete output DO6 [R06]	
13.07	635	Discrete output DO7 [R07]	
13.08	636	Discrete output DO8 [R08]	
13.09	637	Discrete output DO9 [R09]	
13.10	638	Discrete output DO10 [R10]	
13.11	639	Discrete output DO11 [R11]	

Logical Command Variables: Group 14: External Discrete Outputs 1

External discrete outputs 1, Logic command variables 14.01-14.16

The external discrete outputs may be used as command variable in a logical output.

No.	ID	Name / Function	Note
14.01	669	External discrete output DO1 [R.E01]	TRUE = logical "1" (this condition indicates the logical status of the relays, which are connected via external expansion boards) FALSE = logical "0" (this condition indicates the logical status of the relays, which are connected via external expansion boards)
14.02	670	External discrete output DO2 [R.E02]	
14.03	671	External discrete output DO3 [R.E03]	
14.04	672	External discrete output DO4 [R.E04]	
14.05	673	External discrete output DO5 [R.E05]	
14.06	674	External discrete output DO6 [R.E06]	
14.07	675	External discrete output DO7 [R.E07]	
14.08	676	External discrete output DO8 [R.E08]	
14.09	677	External discrete output DO9 [R.E09]	
14.10	678	External discrete output DO10 [R.E10]	
14.11	679	External discrete output DO11 [R.E11]	
14.12	680	External discrete output DO12 [R.E12]	
14.13	681	External discrete output DO13 [R.E13]	
14.14	682	External discrete output DO14 [R.E14]	
14.15	683	External discrete output DO15 [R.E15]	
14.16	684	External discrete output DO16 [R.E16]	

Logical Command Variables: Group 15: Flexible Limits

Flexible limits, Logic command variables 15.01-15.40

The flexible analog input thresholds may be used as command variable in a logical output.

No.	ID	Name / Function	Note
15.01	689	Flexible analog input 1 (triggered)	TRUE = limit value reached FALSE = alarm acknowledged
15.02	690	Flexible analog input 2 (triggered)	
15.03	691	Flexible analog input 3 (triggered)	
15.04	692	Flexible analog input 4 (triggered)	
15.05	693	Flexible analog input 5 (triggered)	
15.06	694	Flexible analog input 6 (triggered)	
15.07	695	Flexible analog input 7 (triggered)	
15.08	696	Flexible analog input 8 (triggered)	
15.09	697	Flexible analog input 9 (triggered)	
15.10	698	Flexible analog input 10 (triggered)	
15.11	699	Flexible analog input 11 (triggered)	
15.12	700	Flexible analog input 12 (triggered)	
15.13	701	Flexible analog input 13 (triggered)	
15.14	702	Flexible analog input 14 (triggered)	
15.15	703	Flexible analog input 15 (triggered)	
15.16	704	Flexible analog input 16 (triggered)	

Logical Command Variables: Group 18: Transistor Outputs

Transistor outputs, Logic command variables 18.01-18.04

The transistor outputs may be used as command variable in a logical output.

No.	ID	Name / Function	Note
18.05	817	Aux. Excit. active	

Factory Setting



The inputs, outputs, and internal flags, which may be programmed via the *LogicsManager* have the following factory default settings when delivered:

simple (function)	extended (configuration)	result
-------------------	--------------------------	--------

Factory Setting: Functions

[00.0x] Flag {x}; {x} = 1 to 7				
{0}	✓	If TRUE, flag {x} becomes TRUE. Deactivated by default		FALSE
{1o}	✓			
{1oc}	✓			
{2oc}	✓			
STOP	✓			
AUTO	✓			
MAN	✓			
[00.08] Flag 8 - pre-configured to engine start via timer				
{0}	✓	If TRUE, flag 8 becomes TRUE. TRUE once the configured time 1 has been reached [11.01], and the configured time 2 [11.02] has not been reached as well if the current day is the configured day [11.03] (see page 266 "Configure <i>LogicsManager</i> : Set ")		dependent on timer
{1o}	✓			
{1oc}	✓			
{2oc}	✓			
STOP	---			
AUTO	✓			
MAN	---			
[00.09] Start request in Auto				
{0}	✓	If TRUE, the engine is started in AUTOMATIC operating mode. TRUE once discrete input [DI 2] is energized. Note: This function is pre-configured and may be activated by passing through the command variables [00.08] LM: Flag 8 or [04.03] Remote request ('-' instead of '0').		dependent on [DI 2]
{1o}	✓			
{1oc}	✓			
{2oc}	✓			
STOP	---			
AUTO	✓			
MAN	---			

simple (function)	extended (configuration)	result
-------------------	--------------------------	--------

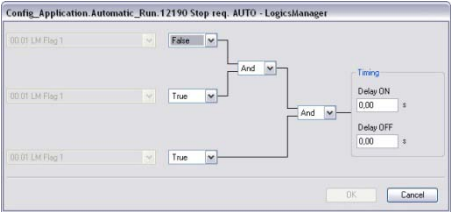
[00.10] Stop request in Auto				
{0}	✓	If TRUE, the engine is either stopped in AUTOMATIC operating mode or a start of the engine is suppressed (also an emergency operation). Deactivated by default		FALSE
{1o}	✓			
{1oc}	✓			
{2oc}	✓			
STOP	---			
AUTO	✓			
MAN	---			

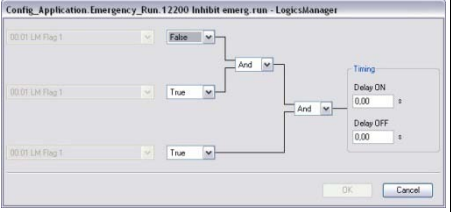
[00.11] Inhibit emergency run				
{0}	---	If TRUE, an emergency operation is inhibited or interrupted. Deactivated by default		FALSE
{1o}	---			
{1oc}	---			
{2oc}	✓			
STOP	---			
AUTO	✓			
MAN	---			

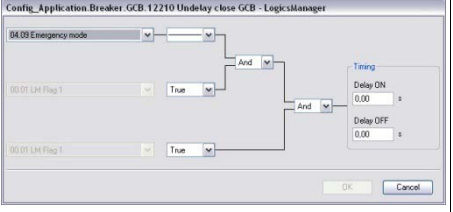
[00.12] Undelay close GCB				
{0}	---	If TRUE, the GCB will be closed in an emergency operation without waiting for expiration of the delayed engine monitoring. TRUE once emergency mode is enabled.		dependent on emergency operation
{1o}	---			
{1oc}	---			
{2oc}	✓			
STOP	---			
AUTO	✓			
MAN	✓			

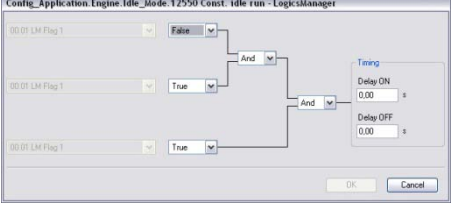
[00.14] Constant Idle run				
{0}	✓	If TRUE, the control outputs an "Constant idle run" if a start request for the generator is present Deactivated by default		FALSE
{1o}	✓			
{1oc}	✓			
{2oc}	✓			
STOP	✓			
AUTO	✓			
MAN	✓			

simple (function)	extended (configuration)	result
-------------------	--------------------------	--------

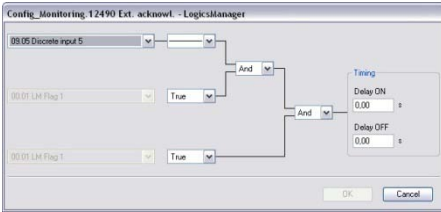
[00.15] External acknowledgment				
{0}	✓	If TRUE, all alarms are acknowledged from an external source. TRUE once discrete input [DI 5] is energized.		dependent on discrete input [DI 5]
{1o}	✓			
{1oc}	✓			
{2oc}	✓			
STOP	✓			
AUTO	✓			
MAN	✓			

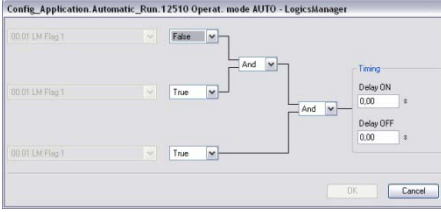
[00.16] Operation mode AUTOMATIC				
{0}	✓	If TRUE the unit changes into AUTOMATIC operating mode. Deactivated by default		FALSE
{1o}	✓			
{1oc}	✓			
{2oc}	✓			
STOP	✓			
AUTO	✓			
MAN	✓			

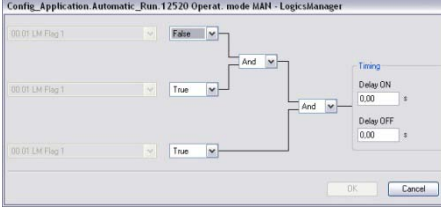
[00.17] Operation mode MANUAL				
{0}	✓	If TRUE the unit changes into MANUAL operating mode. Deactivated by default		FALSE
{1o}	✓			
{1oc}	✓			
{2oc}	✓			
STOP	✓			
AUTO	✓			
MAN	✓			

[00.18] Operation mode STOP				
{0}	✓	If TRUE the unit changes into STOP operating mode. Deactivated by default		FALSE
{1o}	✓			
{1oc}	✓			
{2oc}	✓			
STOP	✓			
AUTO	✓			
MAN	✓			

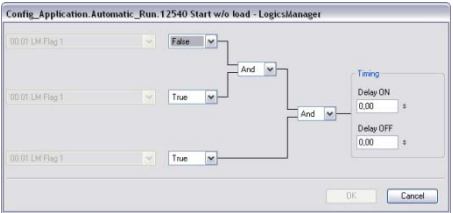
simple (function)		extended (configuration)	result
[00.19] Start without load			
{0}	✓	If TRUE, the engine is started without load transfer to the generator (closing the GCB is blocked). Deactivated by default	
{1o}	✓		
{1oc}	✓		
{2oc}	✓		
STOP	✓		
AUTO	✓		
MAN	✓		FALSE

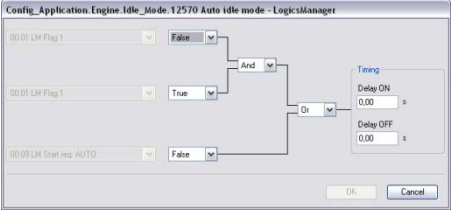
[00.20] Automatic Idle mode			
{0}	✓	If TRUE, the control performs an idle run for a configured time at start-up. Deactivated by default Note: This function is pre-configured and may be activated by passing through the command variable [00.09] Start req. in Auto ('-' instead of '0').	
{1o}	✓		
{1oc}	✓		
{2oc}	✓		
STOP	✓		
AUTO	✓		
MAN	✓		FALSE

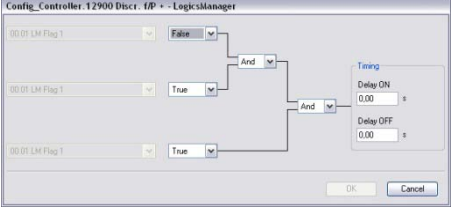
[00.21] Raise frequency/load set point			
{0}	✓	If TRUE, the frequency/load set point will be raised. Deactivated by default	
{1o}	✓		
{1oc}	✓		
{2oc}	✓		
STOP	✓		
AUTO	✓		
MAN	✓		FALSE

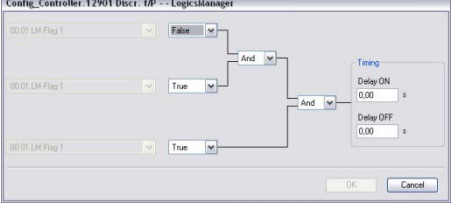
[00.22] Lower frequency/load set point			
{0}	✓	If TRUE, the frequency/load set point will be lowered. Deactivated by default	
{1o}	✓		
{1oc}	✓		
{2oc}	✓		
STOP	✓		
AUTO	✓		
MAN	✓		FALSE

simple (function)	extended (configuration)	result
-------------------	--------------------------	--------

[00.23] Raise voltage/power factor set point				
{0}	✓	If TRUE, the voltage/power factor set point will be raised. Deactivated by default		FALSE
{1o}	✓			
{1oc}	✓			
{2oc}	✓			
STOP	✓			
AUTO	✓			
MAN	✓			

[00.24] Lower voltage/power factor set point				
{0}	✓	If TRUE, the voltage/power factor set point will be lowered. Deactivated by default		FALSE
{1o}	✓			
{1oc}	✓			
{2oc}	✓			
STOP	✓			
AUTO	✓			
MAN	✓			

[00.25] Frequency droop active				
{0}	✓	If TRUE, the frequency droop is enabled. TRUE once missing members are detected on the load share bus.		dependent on missing members
{1o}	✓			
{1oc}	✓			
{2oc}	✓			
STOP	---			
AUTO	✓			
MAN	✓			

[00.26] Voltage droop active				
{0}	✓	If TRUE, the voltage droop is enabled. TRUE once missing members are detected on the load share bus.		dependent on missing members
{1o}	✓			
{1oc}	✓			
{2oc}	✓			
STOP	---			
AUTO	✓			
MAN	✓			

simple (function)		extended (configuration)	result
[00.28] Critical mode			
{0}	✓	If TRUE, the control performs a critical mode operation.	dependent on start failure and [DI 1]
{1o}	✓		
{1oc}	✓		
{2oc}	✓		
STOP	---		
AUTO	✓		
MAN	---		

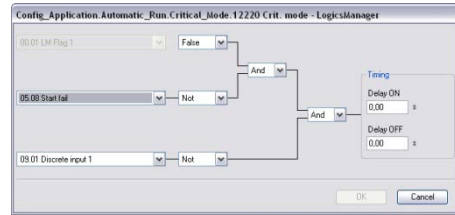

[00.29] Firing speed reached			
{0}	✓	If TRUE, the unit recognizes that the ignition speed has been reached.	FALSE
{1o}	✓		
{1oc}	✓		
{2oc}	✓		
STOP	✓		
AUTO	✓		
MAN	✓		

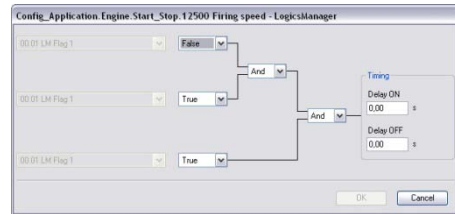

[00.3x] Flag {y}; {x} = 0 to 5, {y} = 9 to 14			
{0}	✓	If TRUE, flag {y} becomes TRUE.	FALSE
{1o}	✓		
{1oc}	✓		
{2oc}	✓		
STOP	---		
AUTO	✓		
MAN	---		

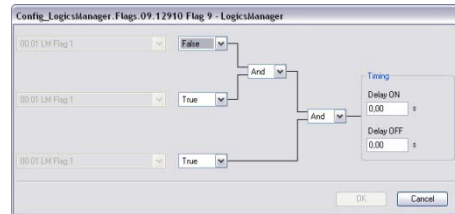

simple (function)	extended (configuration)	result
-------------------	--------------------------	--------

[00.36] Flag 15			
{0}	✓	If TRUE, flag 15 becomes TRUE. Prepared for GCB fail to close or Synchronization time GCB.	
{1o}	✓		
{1oc}	✓		
{2oc}	✓		
STOP	---		
AUTO	✓		
MAN	---		
			 <p>dependent on GCB fail to close and Synchronization time GCB</p>

[00.37] Flag 16			
{0}	✓	If TRUE, flag 16 becomes TRUE. Prepared for Critical mode or Start without load.	
{1o}	✓		
{1oc}	✓		
{2oc}	✓		
STOP	---		
AUTO	✓		
MAN	---		
			 <p>dependent on Critical mode and Start without load</p>

simple (function)	extended (configuration)	result
-------------------	--------------------------	--------

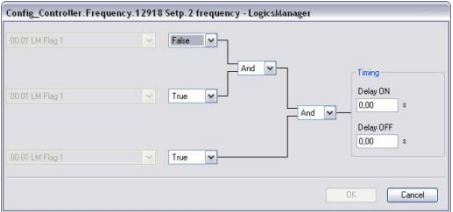
[00.81] Setpoint 2 frequency enabled			
{0}	✓	If TRUE, the frequency set point 2 is enabled.	FALSE
{1o}	✓	Deactivated by default	
{1oc}	✓		
{2oc}	✓		
STOP	---		
AUTO	✓		
MAN	---		
			

[00.82] Setpoint 2 load enabled			
{0}	✓	If TRUE, the load set point 2 is enabled.	FALSE
{1o}	✓	Deactivated by default	
{1oc}	✓		
{2oc}	✓		
STOP	---		
AUTO	✓		
MAN	---		
			

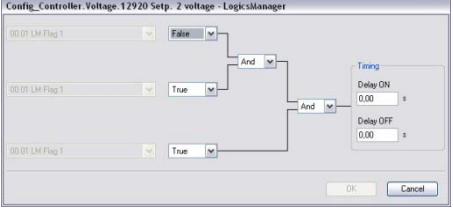
[00.83] Setpoint 2 voltage enabled			
{0}	✓	If TRUE, the voltage set point 2 is enabled.	FALSE
{1o}	✓	Deactivated by default	
{1oc}	✓		
{2oc}	✓		
STOP	---		
AUTO	✓		
MAN	---		
			

simple (function)	extended (configuration)	result
-------------------	--------------------------	--------

[00.84] Setpoint 2 power factor enabled				
{0}	✓	If TRUE, the power factor set point 2 is enabled. Deactivated by default		FALSE
{1o}	✓			
{1oc}	✓			
{2oc}	✓			
STOP	---			
AUTO	✓			
MAN	---			

[00.85] Enable MCB				
{0}	---	If TRUE, the MCB is enabled. TRUE, if discrete input [DI 6] is energized and/or MCB did not fail to close and/or no mains phase rotation mismatch is detected.		dependent on [DI 6] and MCB closure and mains phase rotation
{1o}	---			
{1oc}	---			
{2oc}	✓			
STOP	---			
AUTO	✓			
MAN	---			

[00.86] Load-dependent start/stop				
{0}	---	If TRUE, load-dependent start/stop is enabled. Deactivated by default		FALSE
{1o}	---			
{1oc}	---			
{2oc}	✓			
STOP	---			
AUTO	✓			
MAN	---			

[00.8x] Segment no.{y} active; {x} = 7 to 9; {y} = 2 to 4				
{0}	---	If TRUE, load-dependent start/stop segment no.{y} is enabled. Deactivated by default		FALSE
{1o}	---			
{1oc}	---			
{2oc}	✓			
STOP	---			
AUTO	✓			
MAN	---			

simple (function)	extended (configuration)	result
-------------------	--------------------------	--------

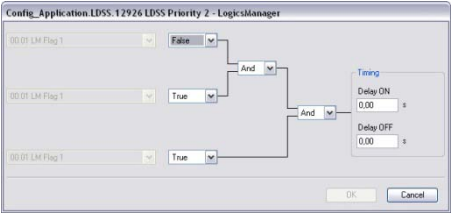
[00.9x] LDSS Priority {y}; {x} = 0 to 2; {y} = 2 to 4			
{0}	---	If TRUE, load-dependent start/stop priority {y} is enabled. Deactivated by default	
{1o}	---		
{1oc}	---		
{2oc}	✓		
STOP	---		
AUTO	✓		
MAN	---		
			FALSE

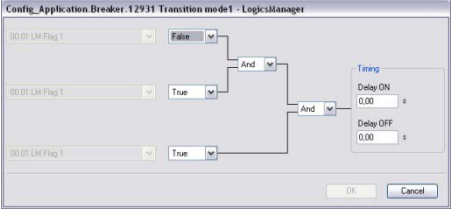
[00.9x] Transition mode {y}; {x} = 3 to 4; {y} = 1 to 2			
{0}	---	If TRUE, transition mode {x} is enabled. Deactivated by default	
{1o}	---		
{1oc}	---		
{2oc}	✓		
STOP	---		
AUTO	✓		
MAN	---		
			FALSE

simple (function)	extended (configuration)	result
-------------------	--------------------------	--------

Factory Setting: Relay Outputs

[00.41] Relay 1 [R01] - Ready for operation OFF		
{0}	✓	Relay will be de-energized if unit is not ready for operation or the logics manager output is TRUE. Deactivated by default Note: This function is pre-configured and may be activated by passing through the command variables [01.09] Shutdown alarm or [04.01] Operating mode AUTO or [00.01] LM: Flag 1 ('-' instead of '0'). The unit is only ready for operation after an start-up delay following the power supply connection.
{1o}	✓	
{1oc}	✓	
{2oc}	✓	
STOP	✓	
AUTO	✓	
MAN	✓	
		FALSE
[00.42] Relay 2 [R02] - Centralized alarm (horn) / freely configurable		
{0}	✓	Relay energizes if the internal condition "Horn" is TRUE
{1o}	✓	
{1oc}	✓	
{2oc}	✓	
STOP	✓	
AUTO	✓	
MAN	✓	
		dependent on Logics Command Variable [03.05]
[00.43] Relay 3 [R03] - Starter / freely configurable		
{0}	✓	Relay energizes if the internal condition "Starter" is TRUE
{1o}	✓	
{1oc}	✓	
{2oc}	✓	
STOP	✓	
AUTO	✓	
MAN	✓	
		dependent on Logics Command Variable [03.02]
[00.44] Relay 4 [R04] - Start/Gas / freely configurable		
{0}	✓	Relay energizes if the internal condition "Start/Gas" is TRUE to energize the start (Diesel) or gas (Gas) solenoid
{1o}	✓	
{1oc}	✓	
{2oc}	✓	
STOP	✓	
AUTO	✓	
MAN	✓	
		dependent on Logics Command Variable [03.28]

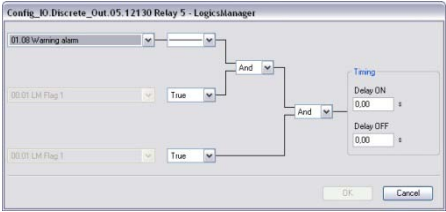
simple (function)	extended (configuration)	result
[00.45] Relay 5 [R05] – Command: open MCB / freely configurable		
{0}	✓ In application mode	
{1o}	✓ {0}, {1o} and {1oc} = freely configurable relay (unassigned)	
{1oc}	✓	
{2oc}	---	
STOP	✓ In application mode {2oc}	
AUTO	✓ "Command: close MCB"	
MAN	✓	dependent on application mode or Logics Command Variable [01.08]

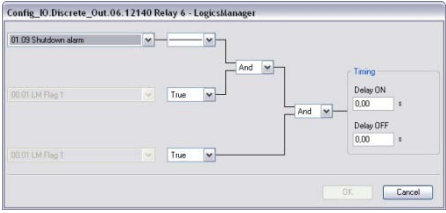
[00.46] Relay 6 [R06] - free / Command: close GCB		
{0}	✓ In application mode	
{1o}	✓ {0} and {1o} = freely configurable relay (unassigned)	
{1oc}	---	
{2oc}	---	
STOP	✓ In application mode {1oc} and {2oc}	
AUTO	✓ "Command: close GCB"	
MAN	✓ Deactivated by default	FALSE

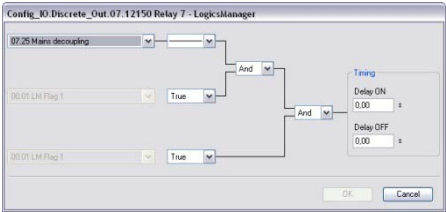
[00.47] Relay 7 [R07] - Mains decoupling / freely configurable / Command: open GCB		
{0}	✓ In application mode {0} pre-configured to mains decoupling. Relay energizes if the internal condition "Mains decoupling" is TRUE to decouple the genset from the mains.	
{1o}	---	
{1oc}	---	
{2oc}	---	
STOP	✓ In application mode	
AUTO	✓ {1o}, {1oc}, and {2oc}	
MAN	✓ "Command: open GCB"	dependent on application mode and Logics Command Variable [07.25]
	Deactivated by default	

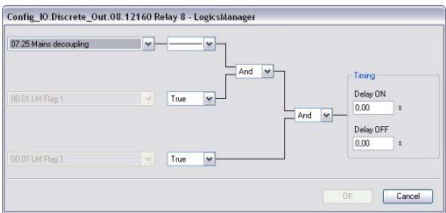
[00.48] Relay 8 [R08] - free / Command: close MCB		
{0}	✓ In application mode	
{1o}	✓ {0}, {1o}, and {1oc} = freely configurable relay (unassigned)	
{1oc}	✓	
{2oc}	---	
STOP	✓ In application mode {2oc}	
AUTO	✓ "Command: close MCB"	
MAN	✓ Deactivated by default	FALSE

simple (function)	extended (configuration)	result
-------------------	--------------------------	--------

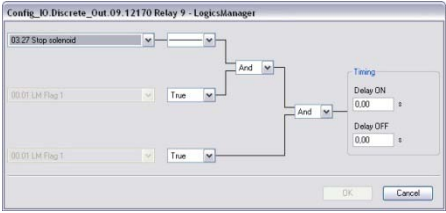
[00.49] Relay 9 [R09] – Stop solenoid / freely configurable				
{0}	✓	Relay energizes if the internal condition "Stop solenoid" is TRUE.		dependent on Logics Command Variable [03.27]
{1o}	✓			
{1oc}	✓			
{2oc}	✓			
STOP	✓			
AUTO	✓			
MAN	✓			

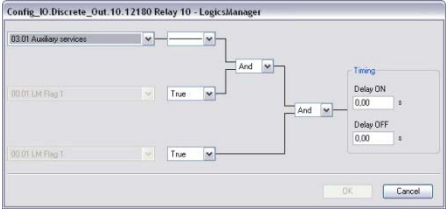
[00.50] Relay 10 [R10] - Auxiliary services / freely configurable				
{0}	✓	Relay energizes if the internal condition "Aux. services" is TRUE to activate the auxiliary services (it energizes prior to an engine start and de-energizes with the engine stop)		dependent on Logics Command Variable [03.01]
{1o}	✓			
{1oc}	✓			
{2oc}	✓			
STOP	✓			
AUTO	✓			
MAN	✓			

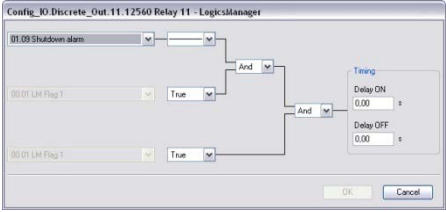
[00.51] Relay 11 [R11] - Shutdown alarm / freely configurable				
{0}	✓	Relay energizes if the internal condition "Shutdown alarm" is TRUE.		dependent on Logics Command Variable [01.09]
{1o}	✓			
{1oc}	✓			
{2oc}	✓			
STOP	✓			
AUTO	✓			
MAN	✓			

simple (function)	extended (configuration)	result
-------------------	--------------------------	--------

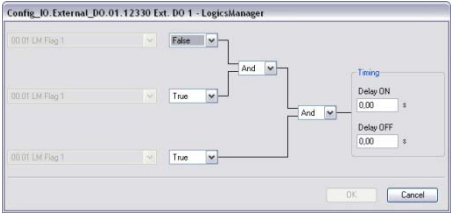
[00.xx] External digital output {y} - free (external expansion card, if connected; {xx} = 63 to 78 ; {y} = 1 to 16)			
{0}	✓	Control of the external relay {y}, if this is connected Prepared for: Deactivated by default	
{1o}	✓		
{1oc}	✓		
{2oc}	✓		
STOP	✓		
AUTO	✓		
MAN	✓		
			FALSE

Discrete Inputs

[DI01]	{0}	freely configurable, pre-assigned to EMERGENCY STOP alarm class F
	{1o}	
	{1oc}	
	{2oc}	
[DI02]	{0}	freely configurable, pre-assigned to <i>LogicsManager</i> Start in AUTO alarm class Control
	{1o}	
	{1oc}	
	{2oc}	
[DI03]	{0}	freely configurable, pre-assigned to Low oil pressure alarm class B
	{1o}	
	{1oc}	
	{2oc}	
[DI04]	{0}	freely configurable, pre-assigned to Coolant temperature alarm class B
	{1o}	
	{1oc}	
	{2oc}	
[DI05]	{0}	freely configurable, pre-assigned to <i>LogicsManager</i> External acknowledgement alarm class Control
	{1o}	
	{1oc}	
	{2oc}	
[DI06]	{0}	freely configurable, pre-assigned to <i>LogicsManager</i> Enable MCB alarm class Control
	{1o}	
	{1oc}	
	{2oc}	
[DI07]	{0}	Reply MCB (not available in the <i>LogicsManager</i>)
	{1o}	
	{1oc}	
	{2oc}	
[DI08]	{0}	Reply GCB (not available in the <i>LogicsManager</i>)
	{1o}	
	{1oc}	
	{2oc}	
[DI09]	{0}	freely configurable discrete input (unassigned) alarm class B
	{1o}	
	{1oc}	
	{2oc}	
[DI10]	{0}	freely configurable discrete input (unassigned) alarm class B
	{1o}	
	{1oc}	
	{2oc}	

Appendix C. Analog Manager



To enhance flexibility of programming the functions of the easYgen-2000 Series, an analog manager is used. All analog values, which are delivered by the easYgen may be used as data sources for the analog outputs (refer to Configure Analog Outputs on page 173), the flexible limit monitoring (refer to Configure Monitoring: Flexible Limits on page 122), and the controller set points (refer to Configure Application: Configure Controller on page 217).

Every data source is indicated by a group number and a sub-number.
Some values are percentage values and relate to reference values.

Data Sources



Group 00: Internal Values

Analog input #	Data source	Reference value
00.01	Engine speed	Rated speed
00.02	Voltage bias	0 to 10000
00.03	Speed bias	0 to 10000
00.04	Battery voltage	Battery voltage 24 V
00.05	Analog input D+ (auxiliary excitation)	Battery voltage 24 V
00.06	Calculated ground current	Generator rated current
00.07	Measured ground current	Ground current transformer ratio setting *

* Refer to parameter 1810 on page Fehler! Textmarke nicht definiert.

Group 01: Generator Values

Analog input #	Data source	Reference value
01.01	Generator voltage wye average (phase-neutral)	Generator rated voltage
01.02	Generator voltage L1-N	Generator rated voltage
01.03	Generator voltage L2-N	Generator rated voltage
01.04	Generator voltage L3-N	Generator rated voltage
01.05	Generator voltage delta average (phase-phase)	Generator rated voltage
01.06	Generator voltage L1-L2	Generator rated voltage
01.07	Generator voltage L2-L3	Generator rated voltage
01.08	Generator voltage L3-L1	Generator rated voltage
01.09	Generator frequency	Rated frequency
01.10	Generator frequency L1-L2	Rated frequency
01.11	Generator frequency L2-L3	Rated frequency
01.12	Generator frequency L3-L1	Rated frequency
01.13	Generator current average	Generator rated current
01.14	Generator current L1	Generator rated current
01.15	Generator current L2	Generator rated current
01.16	Generator current L3	Generator rated current
01.17	Generator maximum current L1	Generator rated current
01.18	Generator maximum current L2	Generator rated current
01.19	Generator maximum current L3	Generator rated current
01.20	Generator power factor	Power factor 1
01.21	Generator power factor L1	Power factor 1
01.22	Generator power factor L2	Power factor 1
01.23	Generator power factor L3	Power factor 1
01.24	Generator total real power	Generator rated real power
01.25	Generator real power L1-N	Generator rated real power
01.26	Generator real power L2-N	Generator rated real power
01.27	Generator real power L3-N	Generator rated real power
01.28	Generator total reactive power	Generator rated reactive power
01.29	Generator reactive power L1-N	Generator rated reactive power
01.30	Generator reactive power L2-N	Generator rated reactive power
01.31	Generator reactive power L3-N	Generator rated reactive power
01.32	Generator total apparent power	Generator rated real and reactive power
01.33	Generator apparent power L1-N	Generator rated real and reactive power
01.34	Generator apparent power L2-N	Generator rated real and reactive power
01.35	Generator apparent power L3-N	Generator rated real and reactive power

Group 02: Mains Values

Analog input #	Data source	Reference value
02.01	Mains voltage wye average (phase-neutral)	Mains rated voltage
02.02	Mains voltage L1-N	Mains rated voltage
02.03	Mains voltage L2-N	Mains rated voltage
02.04	Mains voltage L3-N	Mains rated voltage
02.05	Mains voltage delta average (phase-phase)	Mains rated voltage
02.06	Mains voltage L1-L2	Mains rated voltage
02.07	Mains voltage L2-L3	Mains rated voltage
02.08	Mains voltage L3-L1	Mains rated voltage
02.09	Mains frequency	Rated frequency
02.10	Mains frequency L1-L2	Rated frequency
02.11	Mains frequency L2-L3	Rated frequency
02.12	Mains frequency L3-L1	Rated frequency
02.13	Mains current average	Mains rated current
02.14	Mains current L1	Mains rated current
02.17	Maximum mains current L1	Mains rated current
02.20	Mains power factor	Power factor 1
02.21	Mains power factor L1	Power factor 1
02.24	Mains total power	Mains rated real power
02.25	Mains power L1-N	Mains rated real power
02.28	Mains total reactive power	Mains rated reactive power
02.29	Mains reactive power L1-N	Mains rated reactive power
02.32	Mains total apparent power	Mains rated real and reactive power
02.33	Mains apparent power L1-N	Mains rated real and reactive power

Group 05: Controller Set Points

Analog input #	Data source	Reference value
05.01	Internal frequency set point 1	
05.02	Internal frequency set point 2	
05.03	Interface frequency set point	
05.04	Internal power set point 1	
05.05	Internal power set point 2	
05.06	Interface power set point	
05.07	Internal voltage set point 1	
05.08	Internal voltage set point 2	
05.09	Interface voltage set point	
05.10	Internal power factor set point 1	
05.11	Internal power factor set point 2	
05.12	Interface power factor set point	
05.13	Discrete f +/-	
05.14	Discrete P +/-	
05.15	Discrete V +/-	
05.16	Discrete PF +/-	
05.17	Used frequency setpoint	
05.18	Used frequency setpoint ramp	
05.19	Used power setpoint	
05.20	Used power setpoint ramp	
05.21	Used voltage setpoint	
05.22	Used voltage setpoint ramp	
05.23	Used PF setpoint	
05.24	Used PF setpoint ramp	

Group 06: DC Analog Input Values

Analog input #	Data source	Reference value
06.01	Analog input 1	Display value format*
06.02	Analog input 2	Display value format*
06.03	Analog input 3	Display value format*
06.04	Analog input 4	Display value format*

* Refer to Table 3-122 on page 309 for more information

If the analog input type (parameter 1000 on page 162) is configured to VDO or Pt100, the following display value formats apply:

Analog input type	Display value format	Example value	Example format
Table A/B	1%	10%	10
Linear	-	453	453
Pt100	1°C	103°C	103
VDO 120°C	1°C	69°C	69
VDO 150°C	1°C	73°C	73
VDO 10 bar	0.01 bar	6.6 bar	660
VDO 5 bar	0.01 bar	5.0 bar	500
Off	-	-	-

Table 3-122: Analog Manager - display value format

Group 07: Engine Values

Analog input #	Data source	Reference value
07.01	SPN 52: Engine Intercooler	
07.02	SPN 91: Throttle Position	
07.03	SPN 92: Load At Current Speed	
07.04	SPN 94: Fuel Delivery Pressure	
07.05	SPN 95: Fuel Filter Difference Pressure	
07.06	SPN 98: Engine Oil Level	
07.07	SPN 100: Engine Oil Pressure	
07.08	SPN 101: Crankcase Pressure	
07.09	SPN 102: Boost Pressure	
07.10	SPN 105: Intake Manifold 1 Temperature	
07.11	SPN 106: Turbo Air Inlet Pressure	
07.12	SPN 107: Air Filter 1 Difference Pressure	
07.13	SPN 108: Barometric Pressure	
07.14	SPN 109: Coolant Pressure	
07.15	SPN 110: Engine Coolant Temperature	
07.16	SPN 111: Coolant Level	
07.17	SPN 127: Transmission Oil Pressure	
07.18	SPN 157: Fuel Rail Pressure	
07.19	SPN 171: Ambient Air Temperature	
07.20	SPN 172: Air Inlet Temperature	
07.21	SPN 173: Exhaust Gas Temperature	
07.22	SPN 174: Fuel Temperature	
07.23	SPN 175: Engine Oil Temperature 1	
07.24	SPN 176: Turbo Oil Temperature	
07.25	SPN 177: Transmission Oil Temperature	
07.26	SPN 183: Fuel Rate	
07.27	SPN 190: Engine Speed	
07.28	SPN 441: Auxiliary Temperature 1	
07.29	SPN 442: Auxiliary Temperature 2	
07.30	SPN 513: Actual Engine Torque	
07.31	SPN 1122: Alternator Bearing 1 Temperature	
07.32	SPN 1123: Alternator Bearing 2 Temperature	
07.33	SPN 1124: Alternator Winding 1 Temperature	
07.34	SPN 1125: Alternator Winding 2 Temperature	
07.35	SPN 1126: Alternator Winding 3 Temperature	
07.36	SPN 1131: Intake Manifold 2 Temperature	
07.37	SPN 1132: Intake Manifold 3 Temperature	
07.38	SPN 1133: Intake Manifold 4 Temperature	
07.39	SPN 1134: Engine Thermostat	
07.40	SPN 1135: Engine Oil Temperature 2	
07.41	SPN 1136: Engine ECU Temperature	
07.42	SPN 1137: Exhaust Gas Port 1 Temperature	
07.43	SPN 1138: Exhaust Gas Port 2 Temperature	
07.44	SPN 1139: Exhaust Gas Port 3 Temperature	
07.45	SPN 1140: Exhaust Gas Port 4 Temperature	
07.46	SPN 1141: Exhaust Gas Port 5 Temperature	
07.47	SPN 1142: Exhaust Gas Port 6 Temperature	
07.48	SPN 1143: Exhaust Gas Port 7 Temperature	
07.49	SPN 1144: Exhaust Gas Port 8 Temperature	
07.50	SPN 1145: Exhaust Gas Port 9 Temperature	
07.51	SPN 1146: Exhaust Gas Port 10 Temperature	
07.52	SPN 1147: Exhaust Gas Port 11 Temperature	
07.53	SPN 1148: Exhaust Gas Port 12 Temperature	
07.54	SPN 1149: Exhaust Gas Port 13 Temperature	
07.55	SPN 1150: Exhaust Gas Port 14 Temperature	
07.56	SPN 1151: Exhaust Gas Port 15 Temperature	
07.57	SPN 1152: Exhaust Gas Port 16 Temperature	
07.58	SPN 1153: Exhaust Gas Port 17 Temperature	
07.59	SPN 1154: Exhaust Gas Port 18 Temperature	
07.60	SPN 1155: Exhaust Gas Port 19 Temperature	
07.61	SPN 1156: Exhaust Gas Port 20 Temperature	
07.62	SPN 1157: Main Bearing 1 Temperature	
07.63	SPN 1158: Main Bearing 2 Temperature	
07.64	SPN 1159: Main Bearing 3 Temperature	
07.65	SPN 1160: Main Bearing 4 Temperature	
07.66	SPN 1161: Main Bearing 5 Temperature	
07.67	SPN 1162: Main Bearing 6 Temperature	

Analog input #	Data source	Reference value
07.68	SPN 1163: Main Bearing 7 Temperature	
07.69	SPN 1164: Main Bearing 8 Temperature	
07.70	SPN 1165: Main Bearing 9 Temperature	
07.71	SPN 1166: Main Bearing 10 Temperature	
07.72	SPN 1167: Main Bearing 11 Temperature	
07.73	SPN 1172: Turbo 1 Compressor Inlet Temperature	
07.74	SPN 1173: Turbo 2 Compressor Inlet Temperature	
07.75	SPN 1174: Turbo 3 Compressor Inlet Temperature	
07.76	SPN 1175: Turbo 4 Compressor Inlet Temperature	
07.77	SPN 1176: Turbo 1 Compressor Inlet pressure	
07.78	SPN 1177: Turbo 2 Compressor Inlet pressure	
07.79	SPN 1178: Turbo 3 Compressor Inlet pressure	
07.80	SPN 1179: Turbo 4 Compressor Inlet pressure	
07.81	SPN 1180: Turbo 1 Inlet Temperature	
07.82	SPN 1181: Turbo 2 Inlet Temperature	
07.83	SPN 1182: Turbo 3 Inlet Temperature	
07.84	SPN 1183: Turbo 4 Inlet Temperature	
07.85	SPN 1184: Turbo 1 Outlet Temperature	
07.86	SPN 1185: Turbo 2 Outlet Temperature	
07.87	SPN 1186: Turbo 3 Outlet Temperature	
07.88	SPN 1187: Turbo 4 Outlet Temperature	
07.89	SPN 1203: Engine Auxiliary Coolant Pressure	
07.90	SPN 1208: Pre-Filter Oil Pressure	
07.91	SPN 1212: Engine Auxiliary Coolant Temperature	
07.92	SPN 1382: Fuel Filter Difference Pressure	
07.93	SPN 1800: Battery 1 Temperature	
07.94	SPN 1801: Battery 2 Temperature	
07.95	SPN 1802: Intake Manifold 5 Temperature	
07.96	SPN 1803: Intake Manifold 6 Temperature	
07.97	SPN 2433: Right Exhaust Gas Temperature	
07.98	SPN 2434: Left Exhaust Gas Temperature	
07.99	SPN 2639: Turbocharger 1 Compressor Outlet Temperature	

Reference Values



NOTE

Refer to the **Configure Analog Outputs** section on page 173 for a description of the configuration parameters for the analog output.

Refer to the **Configure Monitoring: Flexible Limits** section on page 121 for a description of the configuration parameters for the flexible limits.

Generator Rated Voltage

All generator voltage values (wye, delta, and average values) refer to the generator rated voltage (parameter 1766 on page 40).

Analog output example:

The generator rated voltage (parameter 1766 on page 40) is configured to 400 V

The source value at maximum output is configured to 110.00% (of the rated voltage i.e. 440 V)

The source value at minimum output is configured to 10.00% (of the rated voltage i.e. 40 V)

The analog output range is configured to 0 to 20 mA

If a generator voltage of 40 V (or below) is measured, the analog output issues its lower limit (i.e. 0 mA)

If a generator voltage of 440 V (or above) is measured, the analog output issues its upper limit (i.e. 20 mA)

If a generator voltage of 240 V is measured, the analog output issues 50 % of its upper limit (i.e. 10 mA)

If a generator voltage of 400 V is measured, the analog output issues 90 % of its upper limit (i.e. 18 mA)

Flexible limit example:

The generator rated voltage (parameter 1766 on page 40) is configured to 400 V

If the flexible limit is to be configured to 110.00% (of the rated voltage i.e. 440 V), it must be entered as 11000

Mains Rated Voltage

All mains voltage values (wye, delta, average, and peak values) refer to the mains rated voltage (parameter 1768 on page 40).

Analog output example:

The mains rated voltage (parameter 1768 on page 40) is configured to 400 V

The source value at maximum output is configured to 110.00% (of the rated voltage i.e. 440 V)

The source value at minimum output is configured to 10.00% (of the rated voltage i.e. 40 V)

The analog output range is configured to 0 to 20 mA

If a mains voltage of 40 V (or below) is measured, the analog output issues its lower limit (i.e. 0 mA)

If a mains voltage of 440 V (or above) is measured, the analog output issues its upper limit (i.e. 20 mA)

If a mains voltage of 240 V is measured, the analog output issues 50 % of its upper limit (i.e. 10 mA)

If a mains voltage of 400 V is measured, the analog output issues 90 % of its upper limit (i.e. 18 mA)

Flexible limit example:

The mains rated voltage (parameter 1768 on page 40) is configured to 400 V

If the flexible limit is to be configured to 110.00% (of the rated voltage i.e. 440 V), it must be entered as 11000

Rated Frequency

All frequency values (generator, mains, busbar 1) refer to the rated system frequency (parameter 1750 on page 39).

Analog output example:

The rated system frequency (parameter 1750 on page 39) is configured to 50 Hz

The source value at maximum output is configured to 110.00% (of the rated frequency i.e. 55 Hz)

The source value at minimum output is configured to 90.00% (of the rated frequency i.e. 45 Hz)

The analog output range is configured to 0 to 20 mA

If a frequency of 45 Hz (or below) is measured, the analog output issues its lower limit (i.e. 0 mA)

If a frequency of 55 Hz (or above) is measured, the analog output issues its upper limit (i.e. 20 mA)

If a frequency of 50 Hz is measured, the analog output issues 50 % of its upper limit (i.e. 10 mA)

If a frequency of 51 Hz is measured, the analog output issues 60 % of its upper limit (i.e. 12 mA)

Flexible limit example:

The rated system frequency (parameter 1750 on page 39) is configured to 50 Hz

If the flexible limit is to be configured to 105.00% (of the rated frequency i.e. 52.5 Hz), it must be entered as 10500

Generator Rated Active Power

All generator active power values refer to the generator rated active power (parameter 1752 on page 40).

Analog output example:

The generator rated active power (parameter 1752 on page 40) is configured to 500 kW

The source value at maximum output is configured to 120.00% (of the rated active power i.e. 600 kW)

The source value at minimum output is configured to 0.00% (of the rated active power i.e. 0 kW)

The analog output range is configured to 0 to 20 mA

If an active power of 0 kW is measured, the analog output issues its lower limit (i.e. 0 mA)

If an active power of 600 kW (or above) is measured, the analog output issues its upper limit (i.e. 20 mA)

If an active power of 300 kW is measured, the analog output issues 50 % of its upper limit (i.e. 10 mA)

If an active power of 120 kW is measured, the analog output issues 20 % of its upper limit (i.e. 4 mA)

Flexible limit example:

The generator rated active power (parameter 1752 on page 40) is configured to 500 kW

If the flexible limit is to be configured to 120.00% (of the rated active power i.e. 600 kW), it must be entered as 12000

Generator Rated Reactive Power

All generator reactive power values refer to the generator rated reactive power (parameter 1758 on page 40).

Analog output example:

The generator rated reactive power (parameter 1758 on page 40) is configured to 500 kvar
The source value at maximum output is configured to 120.00% (of the rated reactive power i.e. 600 kvar)
The source value at minimum output is configured to 0.00% (of the rated reactive power i.e. 0 kvar)
The analog output range is configured to 0 to 20 mA

If a reactive power of 0 kvar is measured, the analog output issues its lower limit (i.e. 0 mA)
If a reactive power of 600 kvar (or above) is measured, the analog output issues its upper limit (i.e. 20 mA)
If a reactive power of 300 kvar is measured, the analog output issues 50 % of its upper limit (i.e. 10 mA)
If a reactive power of 120 kvar is measured, the analog output issues 20 % of its upper limit (i.e. 4 mA)

Flexible limit example:

The generator rated reactive power (parameter 1758 on page 40) is configured to 500 kvar
If the flexible limit is to be configured to 120.00% (of the rated reactive power i.e. 600 kvar), it must be entered as 12000



NOTE

Above example is valid for inductive/lagging power. If capacitive/leading power is to be output, the settings for the source value at min/max output must be negative.

Mains Rated Active Power

All mains active power values refer to the mains rated active power (parameter 1748 on page 40).

Analog output example:

The mains rated active power (parameter 1748 on page 40) is configured to 500 kW
The source value at maximum output is configured to 120.00% (of the rated active power i.e. 600 kW)
The source value at minimum output is configured to 0.00% (of the rated active power i.e. 0 kW)
The analog output range is configured to 0 to 20 mA

If a real power of 0 kW is measured, the analog output issues its lower limit (i.e. 0 mA)
If a real power of 600 kW (or above) is measured, the analog output issues its upper limit (i.e. 20 mA)
If a real power of 300 kW is measured, the analog output issues 50 % of its upper limit (i.e. 10 mA)
If a real power of 120 kW is measured, the analog output issues 20 % of its upper limit (i.e. 4 mA)

Flexible limit example:

The mains rated active power (parameter 1748 on page 40) is configured to 500 kW
If the flexible limit is to be configured to 120.00% (of the rated active power i.e. 600 kW), it must be entered as 12000

Mains Rated Reactive Power

All mains reactive power values refer to the mains rated reactive power (parameter 1746 on page 41).

Analog output example:

The mains rated reactive power (parameter 1746 on page 41) is configured to 500 kvar

The source value at maximum output is configured to 120.00% (of the rated reactive power i.e. 600 kvar)

The source value at minimum output is configured to 0.00% (of the rated reactive power i.e. 0 kvar)

The analog output range is configured to 0 to 20 mA

If a reactive power of 0 kvar is measured, the analog output issues its lower limit (i.e. 0 mA)

If a reactive power of 600 kvar (or above) is measured, the analog output issues its upper limit (i.e. 20 mA)

If a reactive power of 300 kvar is measured, the analog output issues 50 % of its upper limit (i.e. 10 mA)

If a reactive power of 120 kvar is measured, the analog output issues 20 % of its upper limit (i.e. 4 mA)

Flexible limit example:

The mains rated reactive power (parameter 1746 on page 41) is configured to 500 kvar

If the flexible limit is to be configured to 120.00% (of the rated reactive power i.e. 600 kvar), it must be entered as 12000

Generator Rated Apparent Power

All generator apparent power values refer to the generator rated active power (parameter 1752 on page 40) and generator rated reactive power (parameter 1758 on page 40). The generator rated apparent power S is calculated using the real power P and the reactive power Q according to this formula: $S = \sqrt{P^2 + Q^2}$

Analog output example:

The generator rated active power (parameter 1752 on page 40) is configured to 200 kW

The generator rated reactive power (parameter 1758 on page 40) is configured to 200 kvar

The generator rated apparent power is $\sqrt{200^2 + 200^2} = 282.84$ kVA

The source value at maximum output is configured to 120.00% (of the rated apparent power i.e. 339.41 kVA)

The source value at minimum output is configured to 0.00% (of the rated apparent power i.e. 0 kVA)

The analog output range is configured to 0 to 20 mA

If an apparent power of 0 kVA is measured, the analog output issues its lower limit (i.e. 0 mA)

If an apparent power of 339.41 kVA (or above) is measured, the analog output issues its upper limit (i.e. 20 mA)

If an apparent power of 169.71 kVA is measured, the analog output issues 50 % of its upper limit (i.e. 10 mA)

If an apparent power of 67.88 kVA is measured, the analog output issues 20 % of its upper limit (i.e. 4 mA)

Flexible limit example:

The generator rated active power (parameter 1752 on page 40) is configured to 200 kW

The generator rated reactive power (parameter 1758 on page 40) is configured to 200 kvar

The generator rated apparent power is $\sqrt{200^2 + 200^2} = 282.84$ kVA

If the flexible limit is to be configured to 120.00% (of the rated apparent power i.e. 339.41 kVA), it must be entered as 12000

Mains Rated Apparent Power

All mains apparent power values refer to the mains rated active power (parameter 1748 on page 40) and mains rated reactive power (parameter 1746 on page 41). The mains rated apparent power S is calculated using the real power P and the reactive power Q according to this formula: $S = \sqrt{P^2 + Q^2}$

Analog output example:

The mains rated active power (parameter 1748 on page 40) is configured to 200 kW

The mains rated reactive power (parameter 1746 on page 41) is configured to 200 kvar

The mains rated apparent power is $\sqrt{200^2 + 200^2} = 282.84$ kVA

The source value at maximum output is configured to 120.00% (of the rated apparent power i.e. 339.41 kVA)

The source value at minimum output is configured to 0.00% (of the rated apparent power i.e. 0 kVA)

The analog output range is configured to 0 to 20 mA

If an apparent power of 0 kVA is measured, the analog output issues its lower limit (i.e. 0 mA)

If an apparent power of 339.41 kVA (or above) is measured, the analog output issues its upper limit (i.e. 20 mA)

If an apparent power of 169.71 kVA is measured, the analog output issues 50 % of its upper limit (i.e. 10 mA)

If an apparent power of 67.88 kVA is measured, the analog output issues 20 % of its upper limit (i.e. 4 mA)

Flexible limit example:

The mains rated active power (parameter 1748 on page 40) is configured to 200 kW

The mains rated reactive power (parameter 1746 on page 41) is configured to 200 kvar

The mains rated apparent power is $\sqrt{200^2 + 200^2} = 282.84$ kVA

If the flexible limit is to be configured to 120.00% (of the rated apparent power i.e. 339.41 kVA), it must be entered as 12000

Generator / Mains Power Factor

The power factor is scaled linear over a range from 0001 to 9999 according to the following:

Power factor leading 0.01	corresponds with a value of	0001 (i.e. 00.01% of the value range)
Power factor leading 0.50	corresponds with a value of	2500 (i.e. 25.00% of the value range)
Power factor leading 0.80	corresponds with a value of	4000 (i.e. 40.00% of the value range)
Power factor 1.00	corresponds with a value of	5000 (i.e. 50.00% of the value range)
Power factor lagging 0.80	corresponds with a value of	6000 (i.e. 60.00% of the value range)
Power factor lagging 0.50	corresponds with a value of	7500 (i.e. 75.00% of the value range)
Power factor lagging 0.01	corresponds with a value of	9999 (i.e. 99.99% of the value range)

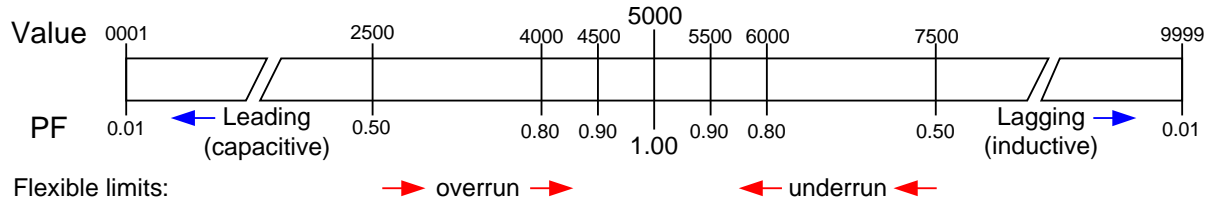

Figure 3-35: Reference values - power factor scaling

Analog output example:

The source value at maximum output is configured to 10000
 The source value at minimum output is configured to 00000
 The analog output range is configured to 0 to 20 mA

If a power factor of leading 0.8 is measured, the analog output issues 40% of its upper limit (i.e. 8 mA)
 If a power factor of leading 1 is measured, the analog output issues 50% of its upper limit (i.e. 10 mA)
 If a power factor of lagging 0.9 is measured, the analog output issues 55% of its upper limit (i.e. 11 mA)

Flexible limit example:

If a power factor of leading 0.95 is measured, the issued value is 4750
 If a power factor of leading 1 is measured, the issued value is 5000
 If a power factor of lagging 0.8 is measured, the issued value is 6000

Generator Rated Current

All generator current values (line, average, and peak values) refer to the generator rated current (parameter 1754 on page 40).

Analog output example:

The generator rated current (parameter 1754 on page 40) is configured to 1000 A

The source value at maximum output is configured to 110.00% (of the rated current i.e. 1100 A)

The source value at minimum output is configured to 10.00% (of the rated current i.e. 100 A)

The analog output range is configured to 0 to 20 mA

If a generator current of 100 A (or below) is measured, the analog output issues its lower limit (i.e. 0 mA)

If a generator current of 1100 A (or above) is measured, the analog output issues its upper limit (i.e. 20 mA)

If a generator current of 600 A is measured, the analog output issues 50 % of its upper limit (i.e. 10 mA)

If a generator current of 300 A is measured, the analog output issues 20 % of its upper limit (i.e. 4 mA)

Flexible limit example:

The generator rated current (parameter 1754 on page 40) is configured to 1000 A

If the flexible limit is to be configured to 110.00% (of the rated current i.e. 1100 A), it must be entered as 11000

Mains Rated Current

All mains current values (line, average, and peak values) refer to the mains rated current (parameter 1785 on page 41).

Analog output example:

The mains rated current (parameter 1785 on page 41) is configured to 1000 A

The source value at maximum output is configured to 110.00% (of the rated current i.e. 1100 A)

The source value at minimum output is configured to 10.00% (of the rated current i.e. 100 A)

The analog output range is configured to 0 to 20 mA

If a mains current of 100 A (or below) is measured, the analog output issues its lower limit (i.e. 0 mA)

If a mains current of 1100 A (or above) is measured, the analog output issues its upper limit (i.e. 20 mA)

If a mains current of 600 A is measured, the analog output issues 50 % of its upper limit (i.e. 10 mA)

If a mains current of 300 A is measured, the analog output issues 20 % of its upper limit (i.e. 4 mA)

Flexible limit example:

The mains rated current (parameter 1785 on page 41) is configured to 1000 A

If the flexible limit is to be configured to 110.00% (of the rated current i.e. 1100 A), it must be entered as 11000

Rated Speed

The measured speed refers to the rated speed (parameter 1601 on page 39).

Analog output example:

The rated speed (parameter 1601 on page 39) is configured to 1500 rpm

The source value at maximum output is configured to 120.00% (of the rated speed i.e. 1800 rpm)

The source value at minimum output is configured to 0.00% (of the rated speed i.e. 0 rpm)

The analog output range is configured to 0 to 20 mA

If a speed of 0 rpm is measured, the analog output issues its lower limit (i.e. 0 mA)

If a speed of 1800 rpm (or above) is measured, the analog output issues its upper limit (i.e. 20 mA)

If a speed of 900 rpm is measured, the analog output issues 50 % of its upper limit (i.e. 10 mA)

If a speed of 1500 rpm is measured, the analog output issues ~83 % of its upper limit (i.e. 16.7 mA)

Flexible limit example:

The rated speed (parameter 1601 on page 39) is configured to 1500 rpm

If the flexible limit is to be configured to 120.00% (of the rated speed i.e. 1800 rpm), it must be entered as 12000

Battery Voltage

The measured battery and auxiliary excitation voltage refer to the fix rated battery voltage of 24 V.

Analog output example:

The source value at maximum output is configured to 120.00% (of the rated voltage i.e. 28.8 V)

The source value at minimum output is configured to 20.00% (of the rated voltage i.e. 4.8 V)

The analog output range is configured to 0 to 20 mA

If a battery voltage of 4.8 V (or below) is measured, the analog output issues its lower limit (i.e. 0 mA)

If a battery voltage of 28.8 V (or above) is measured, the analog output issues its upper limit (i.e. 20 mA)

If a battery voltage of 16.8 V is measured, the analog output issues 50 % of its upper limit (i.e. 10 mA)

If a battery voltage of 24 V is measured, the analog output issues 80 % of its upper limit (i.e. 16 mA)

Flexible limit example:

If the flexible limit is to be configured to 120.00% (of the rated voltage i.e. 28.8 V), it must be entered as 12000

Busbar 1 Rated Voltage

The busbar 1 delta voltage values refer to the busbar 1 rated voltage (parameter 1781 on page 40).

Analog output example:

The busbar 1 rated voltage (parameter 1781 on page 40) is configured to 400 V

The source value at maximum output is configured to 110.00% (of the rated voltage i.e. 440 V)

The source value at minimum output is configured to 10.00% (of the rated voltage i.e. 40 V)

The analog output range is configured to 0 to 20 mA

If a busbar 1 voltage of 40 V (or below) is measured, the analog output issues its lower limit (i.e. 0 mA)

If a busbar 1 voltage of 440 V (or above) is measured, the analog output issues its upper limit (i.e. 20 mA)

If a busbar 1 voltage of 240 V is measured, the analog output issues 50 % of its upper limit (i.e. 10 mA)

If a busbar 1 voltage of 400 V is measured, the analog output issues 90 % of its upper limit (i.e. 18 mA)

Flexible limit example:

The busbar 1 rated voltage (parameter 1781 on page 40) is configured to 400 V

If the flexible limit is to be configured to 110.00% (of the rated voltage i.e. 440 V), it must be entered as 11000

Display Value Format

The analog input values refer to the display value format (refer to parameter 1035 on page 167). Delimiters like decimal points or commas are ignored. If the display value format is 0.01 bar for example, a value of 5 bar corresponds with 00500.

Analog output example:

An analog input is configured to VDO 120°C characteristic.

The source value at maximum output is configured to 00100 (i.e. 100°C)

The source value at minimum output is configured to 00020 (i.e. 20°C)

The analog output range is configured to 0 to 20 mA

If a value of 20°C (or below) is measured, the analog output issues its lower limit (i.e. 0 mA)

If a value of 100°C (or above) is measured, the analog output issues its upper limit (i.e. 20 mA)

If a value of 60°C is measured, the analog output issues 50 % of its upper limit (i.e. 10 mA)

If a value of 84°C is measured, the analog output issues 80 % of its upper limit (i.e. 16 mA)

Flexible limit example:

An analog input is configured to VDO 10 bar characteristic.

If the flexible limit is to be configured to 5.23 bar, it must be entered as 00523

Note: Refer to Table 3-122 on page 309 for more information on the fixed display value formats.

Appendix D. Event History

The event history is a 300-entry FIFO (First In/First Out) memory for logging alarm events and operation states of the unit. As new event messages are entered into the history, the oldest messages are deleted once 300 events have occurred. Refer to the Operation Manual 37428 for additional information about the event history.

Resetting the Event History



NOTE

Be sure to be in the appropriate code level to reset the event history. If you have not entered the correct password for the required code level, the parameters for resetting the event history are not available (refer to the System Management section on page 33 for more information).

The event history can be reset using the parameter "Clear event log" via the front panel.

Resetting the Event History Using the Front Panel

Make sure that you are in code level CL2 or higher (refer to the Enter Password section on page 31). Set the parameter "Clear event log" to Yes (refer to the System Management section on page 33). The complete event history is now being cleared.

Event List

Index	English event text	German event text	Description
14353	AUTO mode	BAW AUTO	Auto mode
14354	STOP mode	BAW STOP	Stop mode
14355	MAN mode	BAW HAND	Manual mode
14700	MCB open	NLS AUF	MCB open
14701	MCB close	NLS ZU	MCB close
14702	GCB open	GLS AUF	GCB open
14703	GCB close	GLS ZU	GCB close
14704	Mains failure	Netzausfall	Mains failure
14705	Emergency run	Notstrombetrieb	Emergency run
14706	Engine is running	Aggregat läuft	Engine is running
14707	Critical mode	Sprinklerbetrieb	Critical mode

Table 3-123: Event history - event list

Alarm List

Index	English event text	German event text	Description
1714	EEPROM failure	EEPROM Fehler	Internal error. EEPROM checksum corrupted.
1912	Gen. overfrequency 1	Gen.Überfrequenz 1	Alarm overfrequency generator threshold 1
1913	Gen. overfrequency 2	Gen.Überfrequenz 2	Alarm overfrequency generator threshold 2
1962	Gen.underfrequency 1	Gen.Unterfrequenz 1	Alarm underfrequency generator threshold 1
1963	Gen.underfrequency 2	Gen.Unterfrequenz 2	Alarm underfrequency generator threshold 2
2012	Gen. overvoltage 1	Gen.Überspannung 1	Alarm overvoltage generator threshold 1
2013	Gen. overvoltage 2	Gen.Überspannung 2	Alarm overvoltage generator threshold 2
2062	Gen. undervoltage 1	Gen.Unterspannung 1	Alarm undervoltage generator threshold 1
2063	Gen. undervoltage 2	Gen.Unterspannung 2	Alarm undervoltage generator threshold 2
2112	Overspeed 1	Überdrehzahl 1	Alarm engine overspeed threshold 1
2113	Overspeed 2	Überdrehzahl 2	Alarm engine overspeed threshold 2
2162	Underspeed 1	Unterdrehzahl 1	Alarm engine underspeed threshold 1
2163	Underspeed 2	Unterdrehzahl 2	Alarm engine underspeed threshold 2
2218	Gen. overcurrent 1	Gen.Überstrom 1	Alarm overcurrent generator threshold 1
2219	Gen. overcurrent 2	Gen.Überstrom 2	Alarm overcurrent generator threshold 2
2220	Gen. overcurrent 3	Gen.Überstrom 3	Alarm overcurrent generator threshold 3
2262	Gen. rev./red. pwr.1	Gen.Rück/Minderlast1	Alarm reverse/reduced power generator threshold 1
2263	Gen. rev./red. pwr.2	Gen.Rück/Minderlast2	Alarm reverse/reduced power generator threshold 2
2314	Gen. overload IOP 1	Gen. Überlast IPB 1	Alarm overload generator IOP threshold 1
2315	Gen. overload IOP 2	Gen. Überlast IPB 2	Alarm overload generator IOP threshold 2
2337	Gen. PF lagging 1	Gen. cos.phi ind. 1	Monitoring generator power factor on exceeding a power factor limit 1. Alarm generator power factor lagging threshold 1.

Index	English event text	German event text	Description
2338	Gen. PF lagging 2	Gen. cos.phi ind. 2	Monitoring generator power factor on exceeding a power factor limit 2. Alarm generator power factor lagging threshold 2.
2362	Gen. overload MOP 1	Gen. Überlast NPB 1	Alarm overload generator MOP threshold 1
2363	Gen. overload MOP 2	Gen. Überlast NPB 2	Alarm overload generator MOP threshold 2
2387	Gen. PF leading 1	Gen. cos.phi kap. 1	Monitoring generator power factor on fall below a power factor limit 1. Alarm generator power factor leading threshold 1.
2388	Gen. PF leading 2	Gen. cos.phi kap. 2	Monitoring generator power factor on fall below a power factor limit 2. Alarm generator power factor leading threshold 2.
2412	Unbalanced load 1	Schiefast 1	Alarm generator unbalanced load threshold 1
2413	Unbalanced load 2	Schiefast 2	Alarm generator unbalanced load threshold 2
2457	Speed/freq. mismatch	Alarm Drehz.erkennng.	Alarm speed detection implausible (generator frequency, pickup, DI are not matching)
2504	Eng. stop malfunct.	Abstellstörung	Alarm shutdown malfunction
2560	Maint. days exceeded	Wartungstage abgel.	Alarm maintenance days overdue
2561	Maint. hrs exceeded	Wartungsstd. abgel.	Alarm maintenance hours overdue
2603	GCB fail to close	GLS ZU Störung	Alarm failed to close GCB
2604	GCB fail to open	GLS AUF Störung	Alarm failed to open GCB
2623	MCB fail to close	NLS ZU Störung	Alarm failed to close MCB
2624	MCB fail to open	NLS AUF Störung	Alarm failed to open MCB
2652	Unintended stop	Ungewollter Stop	Alarm unintended stop
2664	Operat. range failed	Arbeitsber. verfehlt	Alarm operating range failed monitoring
2862	Mains overfreq. 1	Netz Überfrequenz 1	Alarm mains overfrequency threshold 1 (for mains decoupling)
2863	Mains overfreq. 2	Netz Überfrequenz 2	Alarm mains overfrequency threshold 2 (for mains decoupling)
2912	Mains underfreq. 1	Netz Unterfrequenz 1	Alarm mains underfrequency threshold 1 (for mains decoupling)
2913	Mains underfreq. 2	Netz Unterfrequenz 2	Alarm mains underfrequency threshold 2 (for mains decoupling)
2924	Gen act.pwr mismatch	Abweichg. Gen.Wirkl.	Alarm generator active power mismatch
2934	Mns act.pwr mismatch	Abweichg. Netzwirkl.	Alarm mains active power mismatch
2944	Ph.rotation mismatch	Drehfeldfehler	Alarm phase rotation mismatch
2962	Mains overvoltage 1	Netz Überspannung 1	Alarm mains overvoltage threshold 1 (for mains decoupling)
2963	Mains overvoltage 2	Netz Überspannung 2	Alarm mains overvoltage threshold 2 (for mains decoupling)
2985	Mains PF lagging 1	Netz cos.phi ind. 1	Monitoring mains power factor on exceeding a power factor limit 1. Alarm mains power factor lagging threshold 1.
2986	Mains PF lagging 2	Netz cos.phi ind. 2	Monitoring mains power factor on exceeding a power factor limit 2. Alarm mains power factor lagging threshold 2.
3012	Mains undervoltage 1	Netz Unterspannung 1	Alarm mains undervoltage threshold 1 (for mains decoupling)
3013	Mains undervoltage 2	Netz Unterspannung 2	Alarm mains undervoltage threshold 2 (for mains decoupling)
3035	Mains PF leading 1	Netz cos.phi kap. 1	Monitoring mains power factor on fall below a power factor limit 1. Alarm mains power factor leading threshold 1.
3036	Mains PF leading 2	Netz cos.phi kap. 2	Monitoring mains power factor on fall below a power factor limit 2. Alarm mains power factor leading threshold 2.
3057	Mains phase shift	Netz Phasensprung	Alarm mains phase shift for mains decoupling
3064	GCB syn. timeout	GLS Synchron. Zeit	Alarm timeout synchronization GCB
3074	MCB syn. timeout	NLS Synchron. Zeit	Alarm timeout synchronization MCB
3114	Mains decoupling	Netzcentkopplung	Alarm mains decoupling triggered. The mains decoupling function has recognized a mains failure and tripped the breaker.
3124	Gen. unloading fault	Gen. Abschaltstg.	Alarm generator unloading fault. It was not possible to unload the generator within the configurable time.
3217	Mains import power 1	Netz Bezugsstg. 1	Alarm mains import power threshold 1
3218	Mains import power 2	Netz Bezugsstg. 2	Alarm mains import power threshold 2
3241	Mains export power 1	Netz Lieferstg. 1	Alarm mains export power threshold 1
3242	Mains export power 2	Netz Lieferstg. 2	Alarm mains export power threshold 2
3263	Ground fault 1	Erdschluß 1	Alarm ground fault threshold 1
3264	Ground fault 2	Erdschluß 2	Alarm ground fault threshold 2
3325	Start fail	Startfehler	Alarm start fail
3907	Gen. volt. asymmetry	Gen. Spg. Asymmetrie	Alarm generator voltage asymmetry alarm message
3955	Gen.ph.rot. mismatch	Gen. Drehfeld Fehler	Alarm generator phase rotation miswired
3975	Mns.ph.rot. mismatch	Netz Drehfeld Fehler	Alarm mains phase rotation miswired
4038	Inv. time overcurr.	Überstrom AMZ	Alarm generator inverse time overcurrent
4056	Charge alt. low volt	Lichtm. Unterspg.	Alarm battery charge fail monitoring
4064	Missing members	Anzahl Teilnehmer	Number of load share participants does not match
4073	Parameter alignment	Parameterabgleich	Load share participants are not all configured identically
10005	Bat. undervoltage 1	Bat. Unterspannung 1	Alarm battery undervoltage level 1
10006	Bat. undervoltage 2	Bat. Unterspannung 2	Alarm battery undervoltage level 2
10007	Bat. overvoltage 1	Bat. Überspannung 1	Alarm battery overvoltage level 1
10008	Bat. overvoltage 2	Bat. Überspannung 2	Alarm battery overvoltage level 2
10014	Wb:Analog input 1	Db:Analogeingang 1	Analog input1 wire break or short circuit (configurable)
10015	Wb:Analog input 2	Db:Analogeingang 2	Analog input2 wire break or short circuit (configurable)
10017	CAN fault J1939	CAN Fehler J1939	Alarm message: CAN-Error J1939
10018	Flexible limit 1	Flexibler Grenzwert 1	Alarm flexible limit 1 (configurable)
10019	Flexible limit 2	Flexibler Grenzwert 2	Alarm flexible limit 2 (configurable)
10020	Flexible limit 3	Flexibler Grenzwert 3	Alarm flexible limit 3 (configurable)
10021	Flexible limit 4	Flexibler Grenzwert 4	Alarm flexible limit 4 (configurable)

Index	English event text	German event text	Description
10022	Flexible limit 5	Flexibler Grenzwert 5	Alarm flexible limit 5 (configurable)
10023	Flexible limit 6	Flexibler Grenzwert 6	Alarm flexible limit 6 (configurable)
10024	Flexible limit 7	Flexibler Grenzwert 7	Alarm flexible limit 7 (configurable)
10025	Flexible limit 8	Flexibler Grenzwert 8	Alarm flexible limit 8 (configurable)
10026	Flexible limit 9	Flexibler Grenzwert 9	Alarm flexible limit 9 (configurable)
10027	Flexible limit 10	Flexibler Grenzwert 10	Alarm flexible limit 10 (configurable)
10028	Flexible limit 11	Flexibler Grenzwert 11	Alarm flexible limit 11 (configurable)
10029	Flexible limit 12	Flexibler Grenzwert 12	Alarm flexible limit 12 (configurable)
10030	Flexible limit 13	Flexibler Grenzwert 13	Alarm flexible limit 13 (configurable)
10031	Flexible limit 14	Flexibler Grenzwert 14	Alarm flexible limit 14 (configurable)
10032	Flexible limit 15	Flexibler Grenzwert 15	Alarm flexible limit 15 (configurable)
10033	Flexible limit 16	Flexibler Grenzwert 16	Alarm flexible limit 16 (configurable)
10060	Wb:Analog input 3	Db:Analogeingang 3	Wire break or short circuit at analog input 3
10087	CANopen Interface 1	CANopen Interface 1	No data received on CAN bus 1
10088	CANopen Interface 2	CANopen Interface 2	No data received on CAN bus 2
10089	CAN bus overload	CAN-Bus Überlast	Too much messages on all CAN buses
10600	Discrete input 1	Digitaleingang 1	Alarm DI1 (configurable)
10601	Discrete input 2	Digitaleingang 2	Alarm DI2 (configurable)
10602	Discrete input 3	Digitaleingang 3	Alarm DI3 (configurable)
10603	Discrete input 4	Digitaleingang 4	Alarm DI4 (configurable)
10604	Discrete input 5	Digitaleingang 5	Alarm DI5 (configurable)
10605	Discrete input 6	Digitaleingang 6	Alarm DI6 (configurable)
10607	Discrete input 7	Digitaleingang 7	Alarm DI7
10608	Discrete input 8	Digitaleingang 8	Alarm DI8
10609	Discrete input 9	Digitaleingang 9	Alarm DI9 (configurable)
10610	Discrete input 10	Digitaleingang 10	Alarm DI10 (configurable)
15125	Red stop lamp	Rote Stoplampe	Red lamp alarm of J1939
15126	Amber warning lamp	Gelbe Warnlampe	Amber lamp alarm of J1939
16360	Ext. Discrete input 1	Ext. Digitaleingang 1	Alarm external DI1 (configurable)
16361	Ext. Discrete input 2	Ext. Digitaleingang 2	Alarm external DI2 (configurable)
16362	Ext. Discrete input 3	Ext. Digitaleingang 3	Alarm external DI3 (configurable)
16364	Ext. Discrete input 4	Ext. Digitaleingang 4	Alarm external DI4 (configurable)
16365	Ext. Discrete input 5	Ext. Digitaleingang 5	Alarm external DI5 (configurable)
16366	Ext. Discrete input 6	Ext. Digitaleingang 6	Alarm external DI6 (configurable)
16367	Ext. Discrete input 7	Ext. Digitaleingang 7	Alarm external DI7 (configurable)
16368	Ext. Discrete input 8	Ext. Digitaleingang 8	Alarm external DI8 (configurable)
16369	Ext. Discrete input 9	Ext. Digitaleingang 9	Alarm external DI9 (configurable)
16370	Ext. Discrete input 10	Ext. Digitaleingang 10	Alarm external DI10 (configurable)
16371	Ext. Discrete input 11	Ext. Digitaleingang 11	Alarm external DI11 (configurable)
16372	Ext. Discrete input 12	Ext. Digitaleingang 12	Alarm external DI12 (configurable)
16373	Ext. Discrete input 13	Ext. Digitaleingang 13	Alarm external DI13 (configurable)
16374	Ext. Discrete input 14	Ext. Digitaleingang 14	Alarm external DI14 (configurable)
16375	Ext. Discrete input 15	Ext. Digitaleingang 15	Alarm external DI15 (configurable)
16376	Ext. Discrete input 16	Ext. Digitaleingang 16	Alarm external DI16 (configurable)

Table 3-124: Event history - alarm list

Appendix E. Triggering Characteristics

Time-Dependent Overshoot Monitoring



This triggering characteristic is used for time-dependent overcurrent monitoring.

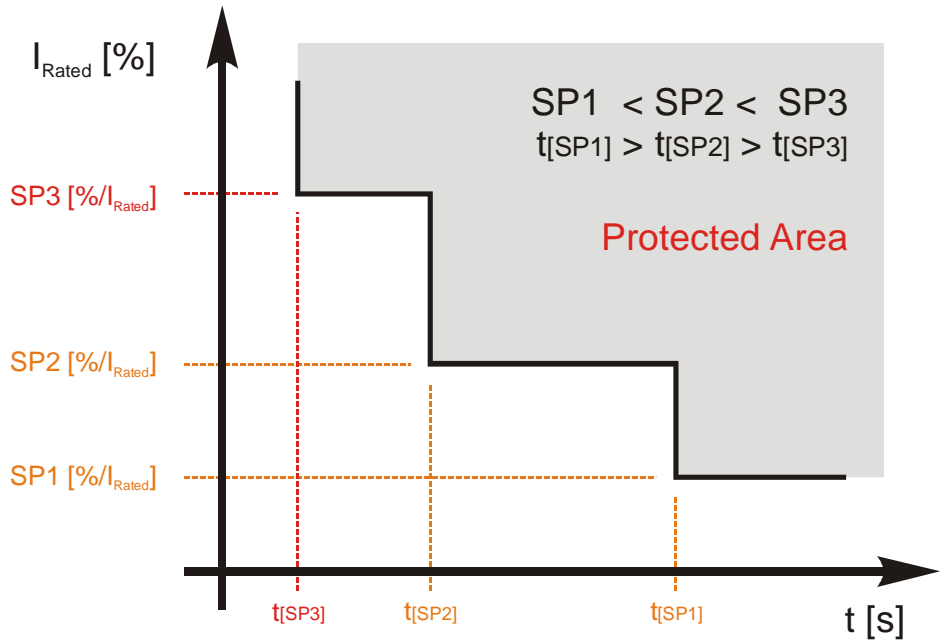

Figure 3-36: Triggering characteristics - three-level time-dependent overshoot monitoring

Two-Level Overshoot Monitoring



This triggering characteristic is used for generator, mains & battery overvoltage, generator & mains overfrequency, overload IOP & MOP, and engine overspeed monitoring.

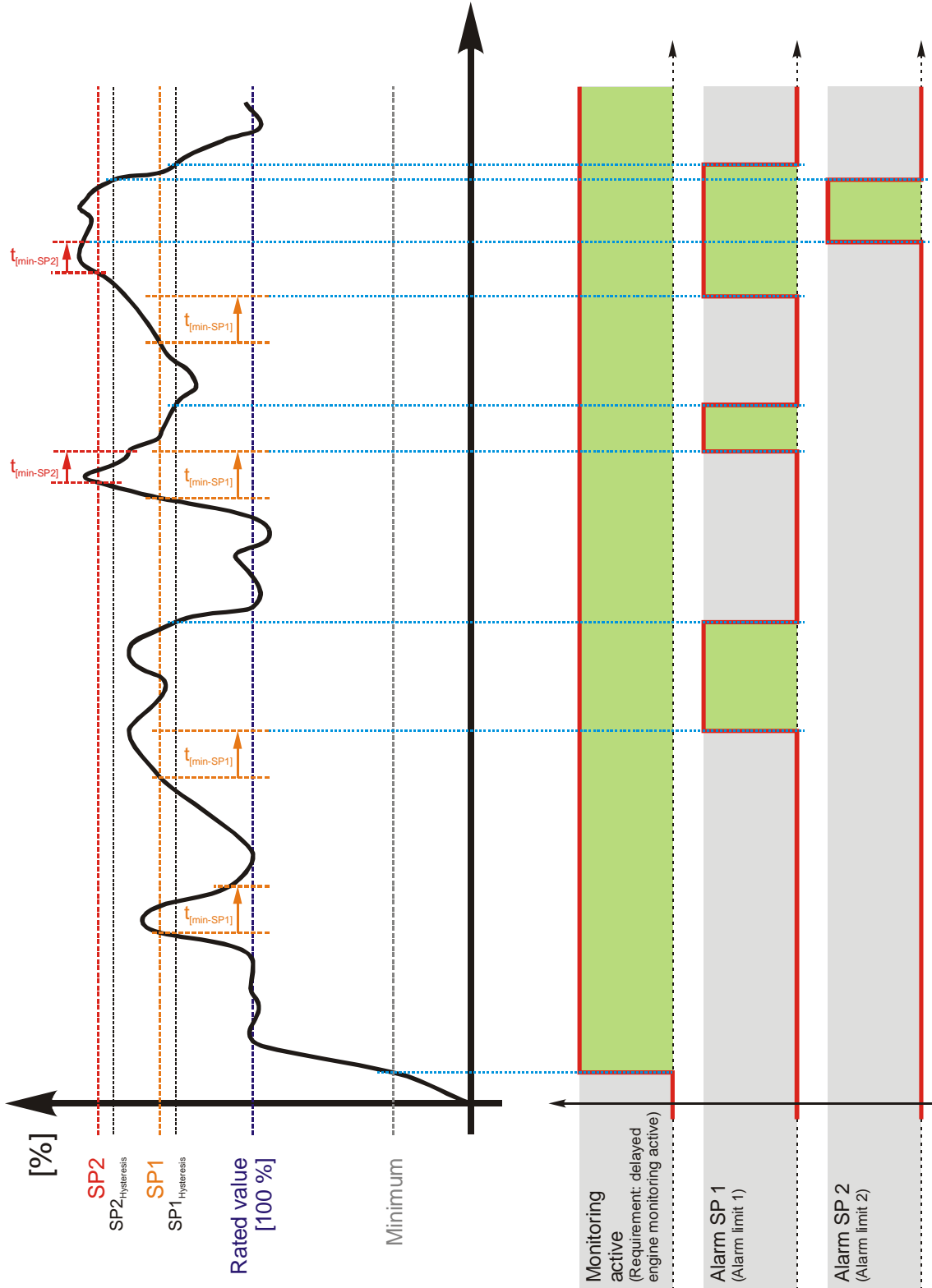

Figure 3-37: Triggering characteristics - two-level overshoot monitoring

Two-Level Undershoot Monitoring



This triggering characteristic is used for generator, mains & battery undervoltage, generator & mains underfrequency, and engine underspeed monitoring.

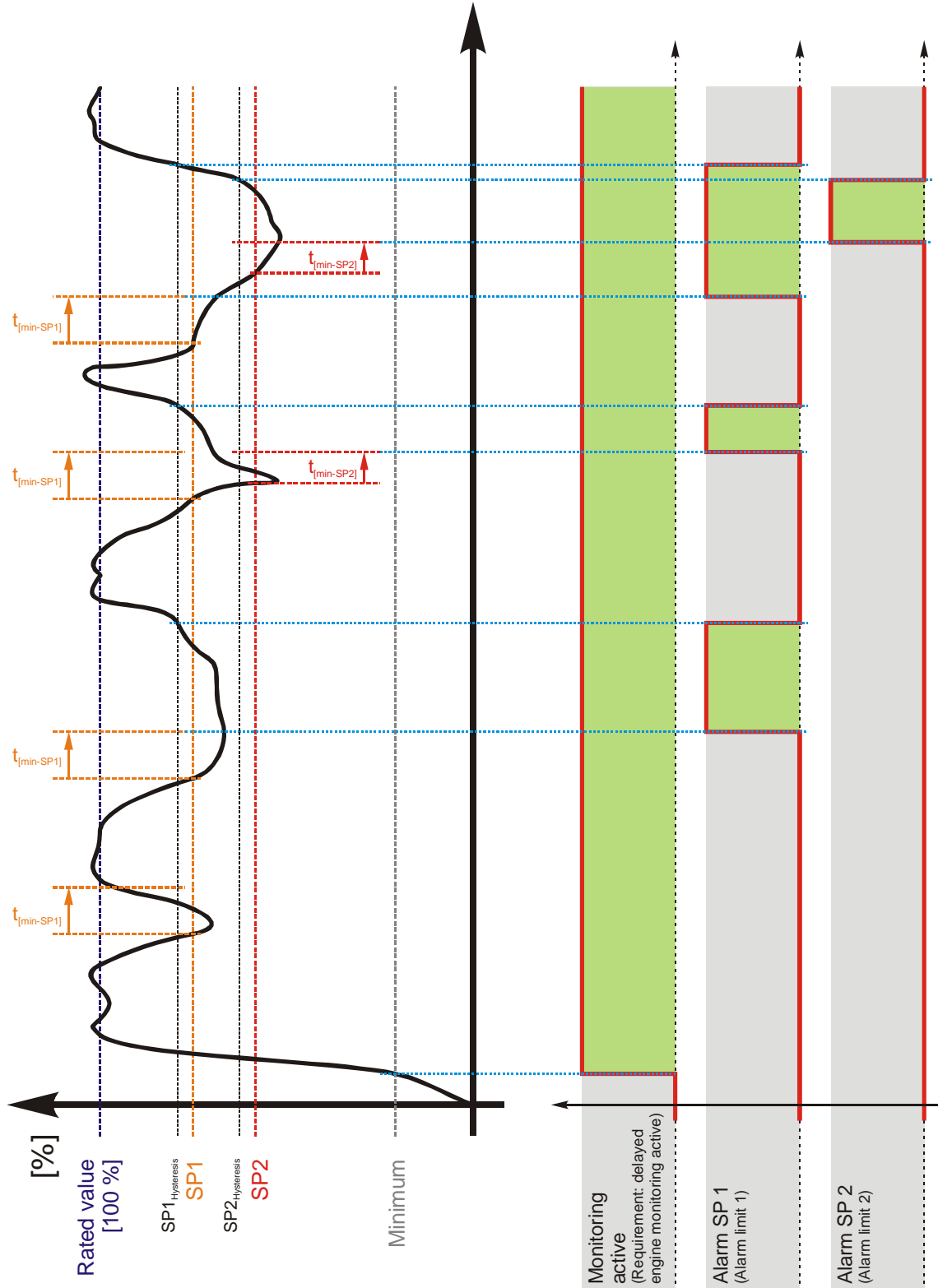

Figure 3-38: Triggering characteristics - two-level undershoot monitoring

Two-Level Reversed/Reduced Load Monitoring



This triggering characteristic is used for generator reversed/reduced load monitoring.

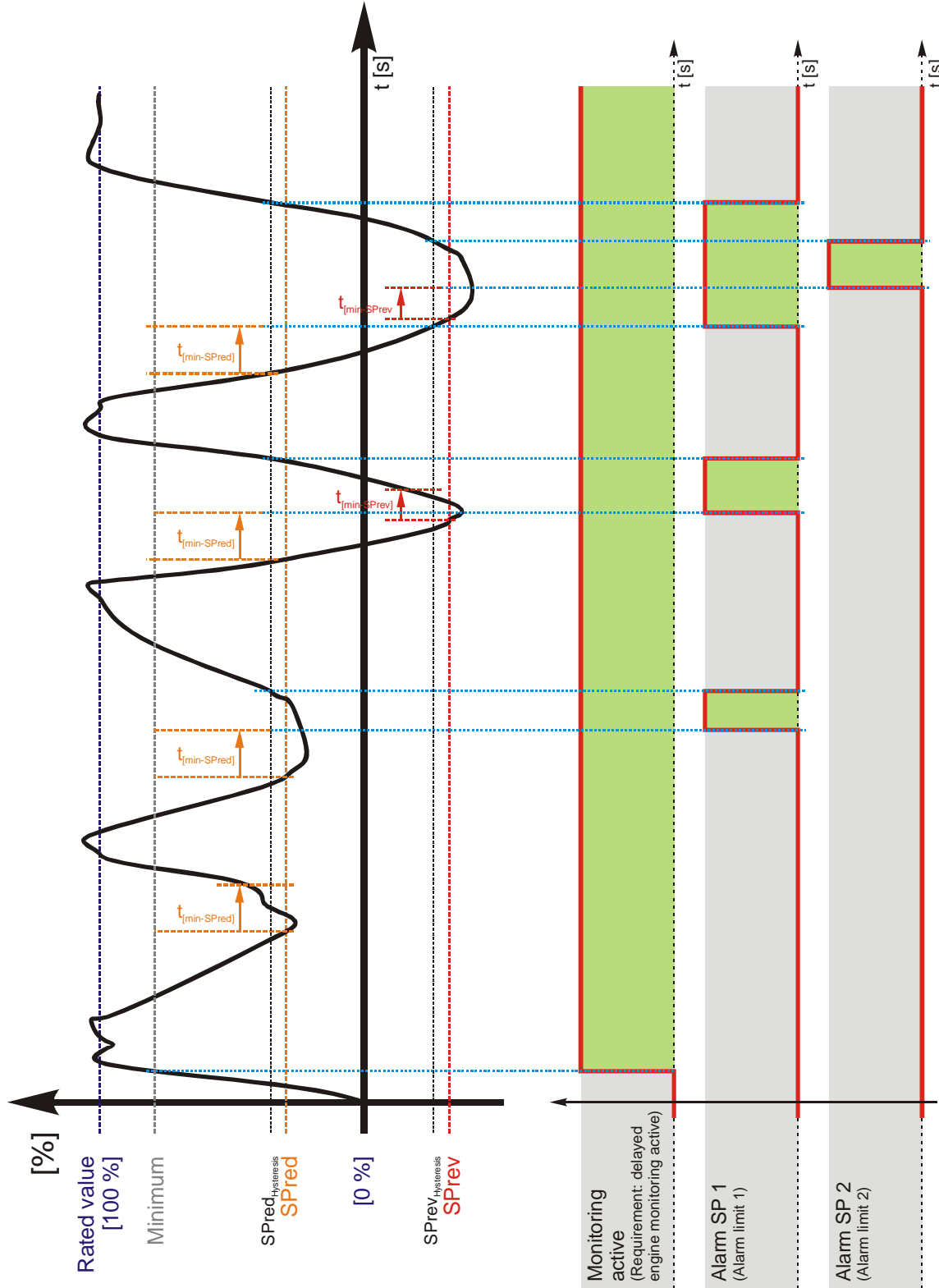

Figure 3-39: Triggering characteristics - two-level reversed/reduced load monitoring

Two-Level Unbalanced Load Monitoring



This triggering characteristic is used for generator unbalanced load monitoring.

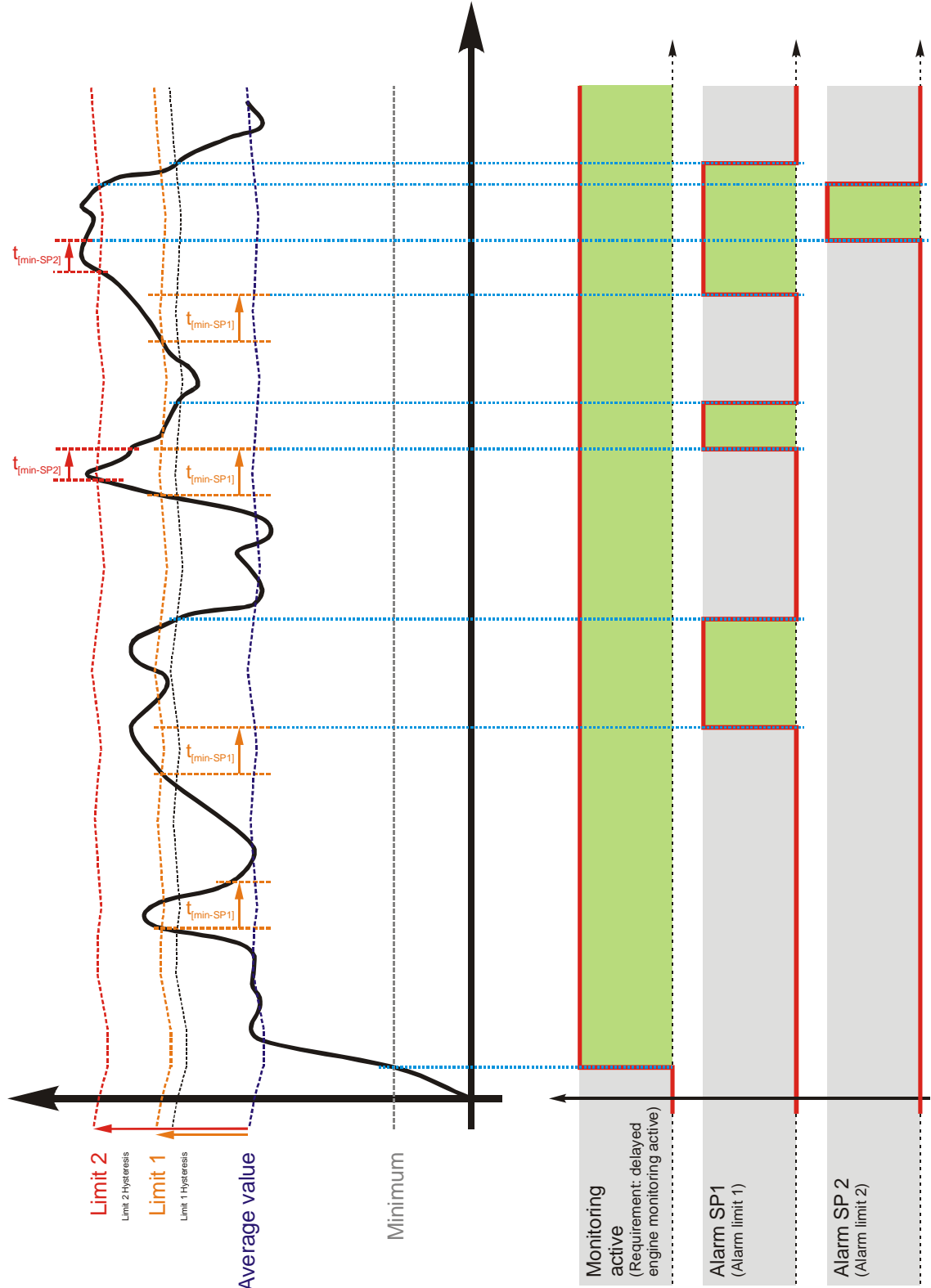

Figure 3-40: Triggering characteristics - two-level unbalanced load monitoring

One-Level Asymmetry Monitoring



This triggering characteristic is used for generator voltage asymmetry monitoring.

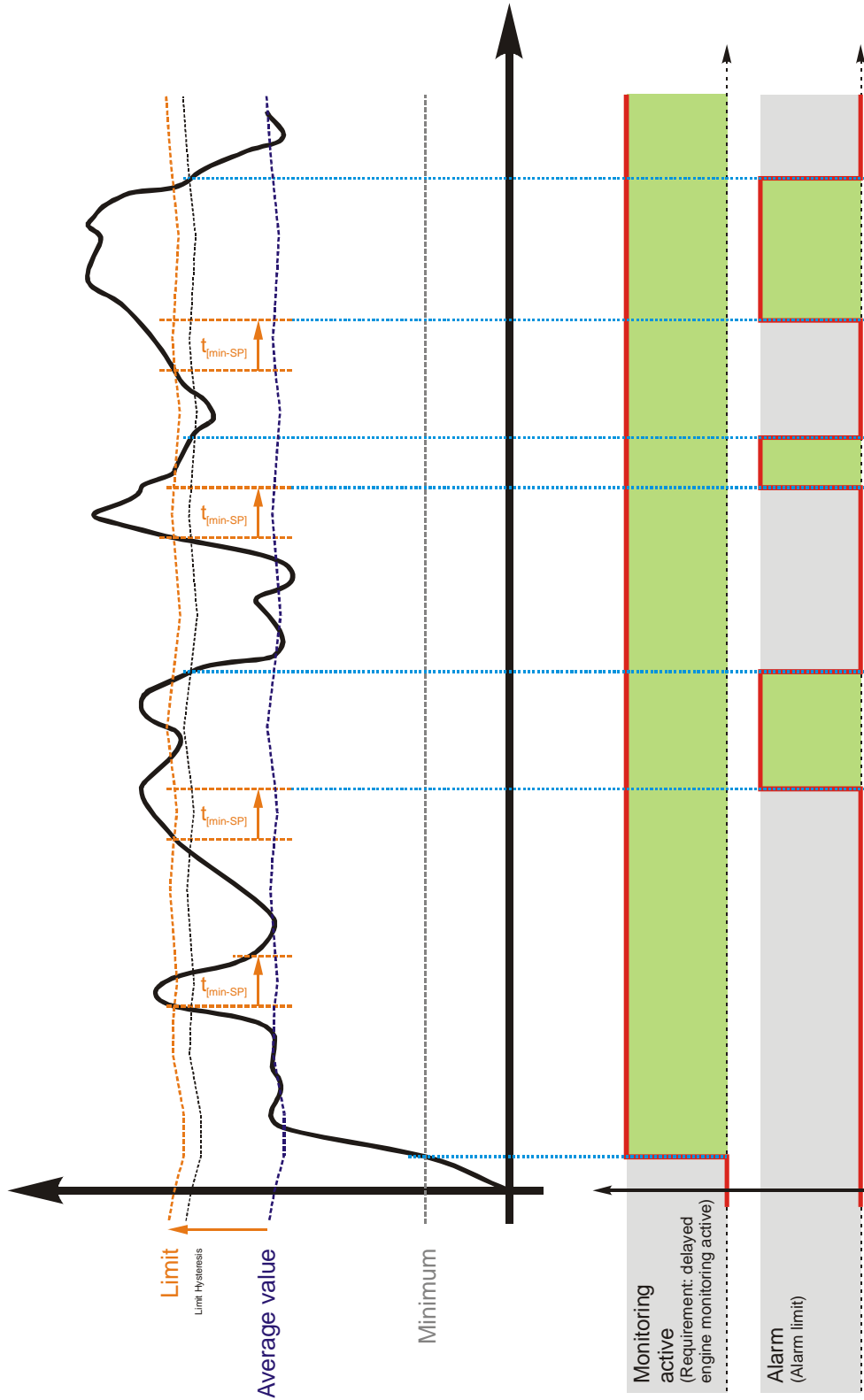

Figure 3-41: Triggering characteristics - one-level asymmetry monitoring

Appendix F. Characteristics Of The VDO Inputs

Since VDO sensors are available in various different types, the Index Numbers of the characteristic curve tables are listed. The customer must observe to order a sensor with the correct characteristic curve when selecting a VDO sensor. Manufacturers of VDO sensors usually list these tables in their catalogs.

VDO Input "Pressure" (0 to 5 bar / 0 to 72 psi) - Index "III"



VDO Pres. 0-5 bar Index "III"

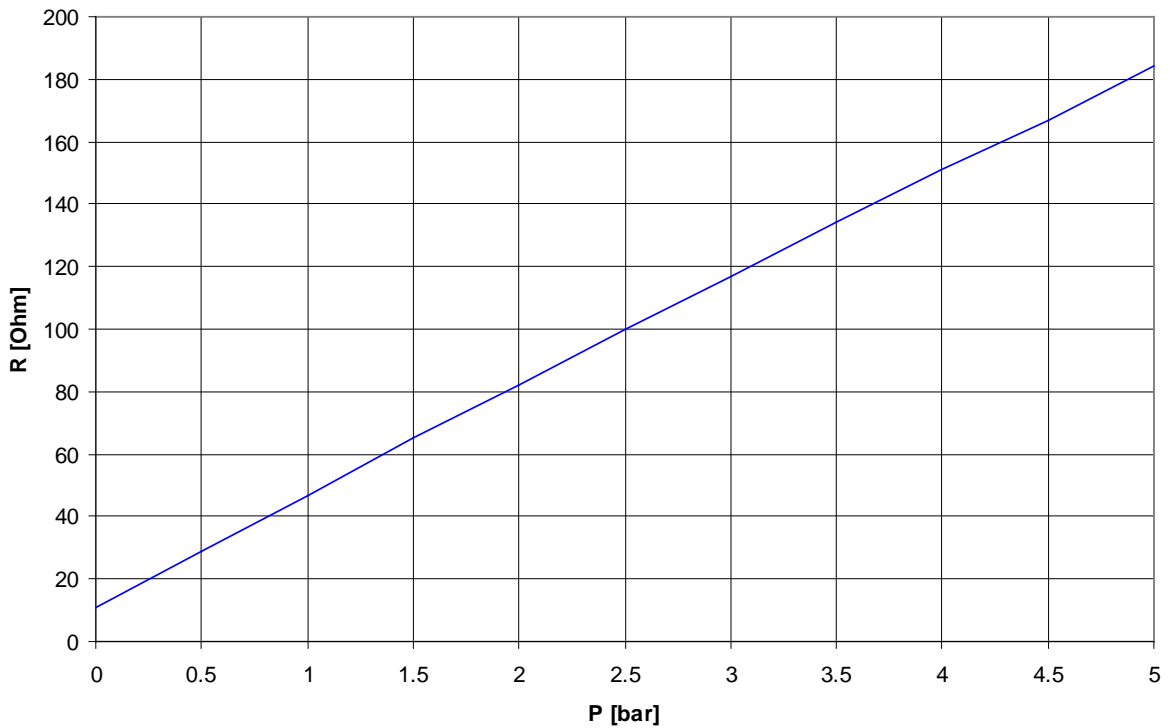

Figure 3-42: Analog inputs - characteristics diagram VDO 0 to 5 bar, Index "III"

P [bar]	0	0.5	1	1.5	2	2.5	3	3.5	4	4.5	5
P [psi}	0	7.25	14.50	21.76	29.00	36.26	43.51	50.76	58.02	65.27	72.52
R [Ohm]	11	29	47	65	82	100	117	134	151	167	184

Table 3-125: Analog inputs - characteristics diagram VDO 0 to 5 bar, Index "III"

VDO Input "Pressure" (0 to 10 bar / 0 to 145 psi) - Index "IV"



VDO Pres. 0-10 bar Index "IV"

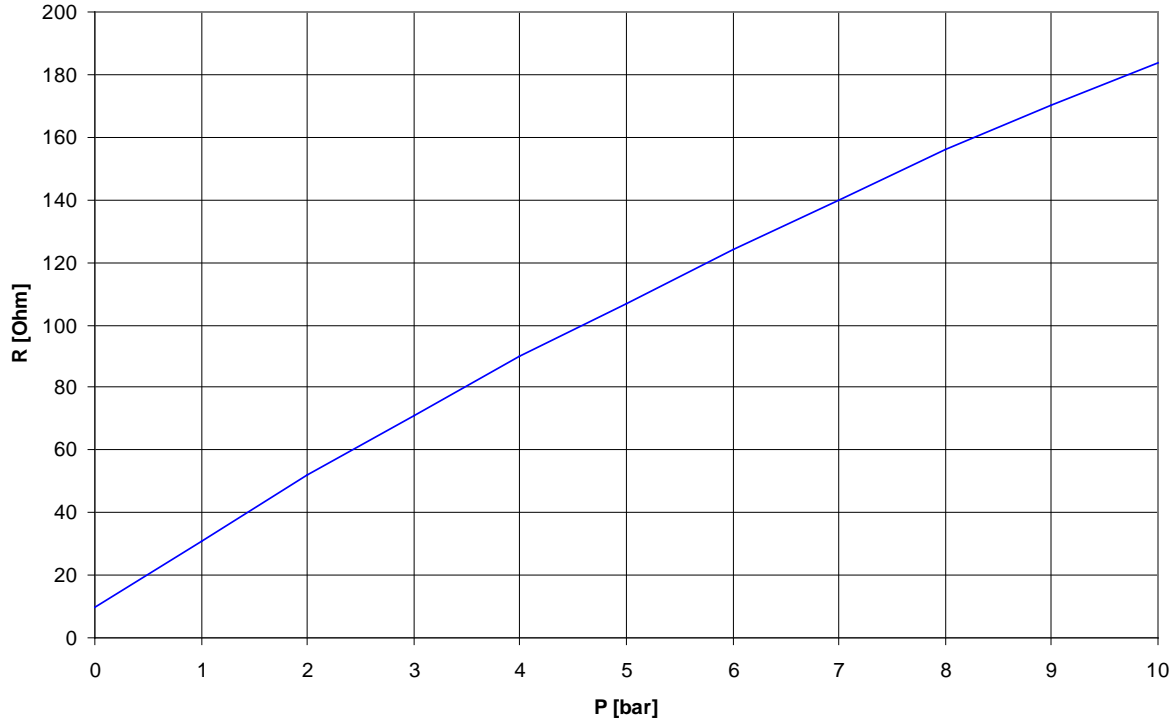

Figure 3-43: Analog inputs - characteristics diagram VDO 0 to 10 bar, Index "IV"

P [bar]	0	0.5	1	1.5	2	3	4	5	6	7	8	8.5	9	10
P [psi]	0	7.25	14.50	21.76	29.00	43.51	58.02	72.52	87.02	101.53	116.03	123.28	130.53	145.04
R [Ohm]	10	21	31	42	52	71	90	107	124	140	156	163	170	184

Table 3-126: Analog inputs - characteristics diagram VDO 0 to 10 bar, Index "IV"

VDO Input "Temperature" (40 to 120 °C / 104 to 248 °F) - Index "92-027-004"



VDO Temp. 40-120 °C 92-027-004

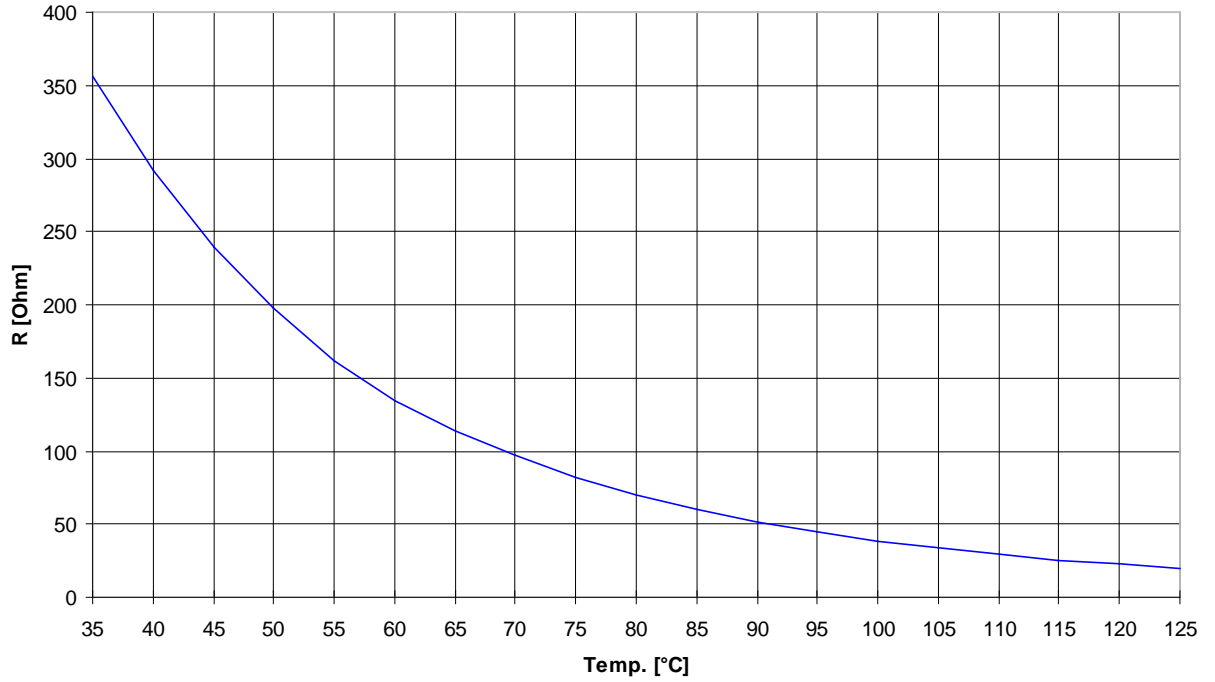

Figure 3-44: Analog inputs - characteristics diagram VDO 40 to 120 °C, Index "92-027-004"

Temp. [°C]	40	45	50	55	60	65	70	75	80
Temp. [°F]	104	113	122	131	140	149	158	167	176
R [Ohm]	291.46	239.56	197.29	161.46	134.03	113.96	97.05	82.36	70.12
Temp. [°C]	85	90	95	100	105	110	115	120	
Temp. [°F]	185	194	203	212	221	230	239	248	
R [Ohm]	59.73	51.21	44.32	38.47	33.40	29.12	25.53	22.44	

Table 3-127: Analog inputs - characteristics diagram VDO 40 to 120 °C, Index "92-027-004"

VDO Input "Temperature" (50 to 150 °C / 122 to 302 °F) - Index "92-027-006"



VDO Temp. 50-150 °C 92-027-006

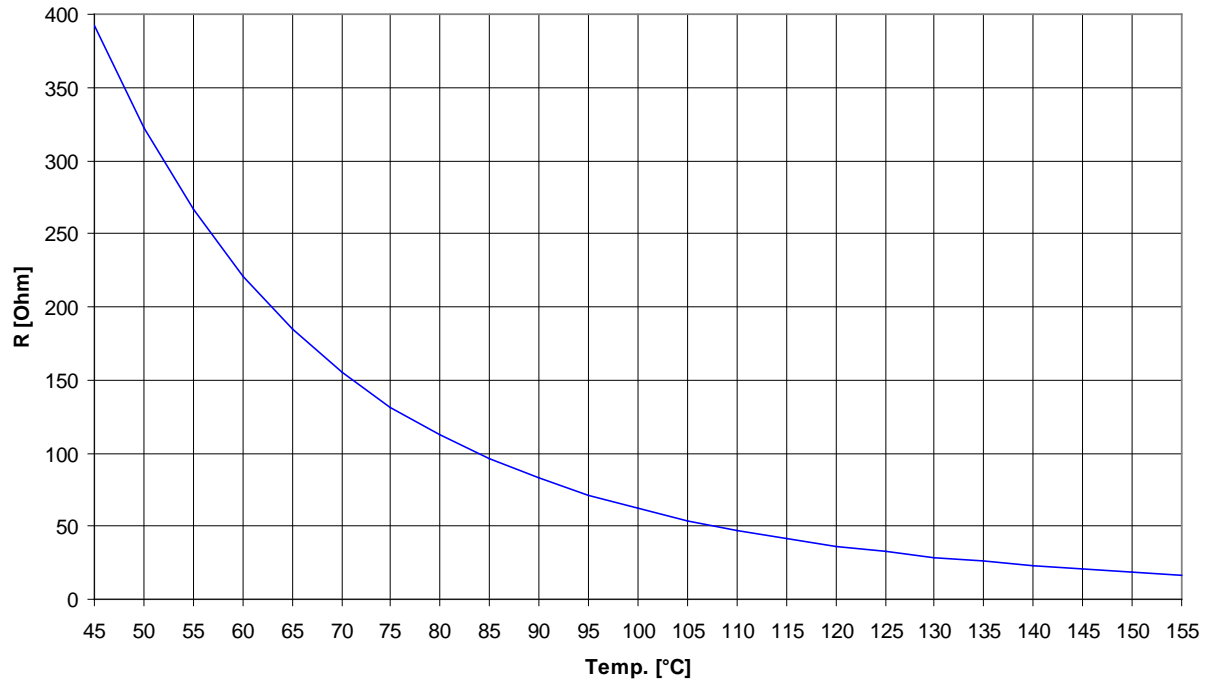

Figure 3-45: Analog inputs - characteristics diagram VDO 50 to 150 °C, Index "92-027-006"

Temp. [°C]	50	55	60	65	70	75	80	85	90	95	100
Temp. [°F]	122	131	140	149	158	167	176	185	194	203	212
R [Ohm]	322.17	266.19	221.17	184.72	155.29	131.38	112.08	96.40	82.96	71.44	61.92
Temp. [°C]	105	110	115	120	125	130	135	140	145	150	
Temp. [°F]	221	230	239	248	257	266	275	284	293	302	
R [Ohm]	54.01	47.24	41.42	36.51	32.38	28.81	25.70	23.00	20.66	18.59	

Table 3-128: Analog inputs - characteristics diagram VDO 50 to 150 °C, Index "92-027-006"

Pt100 RTD

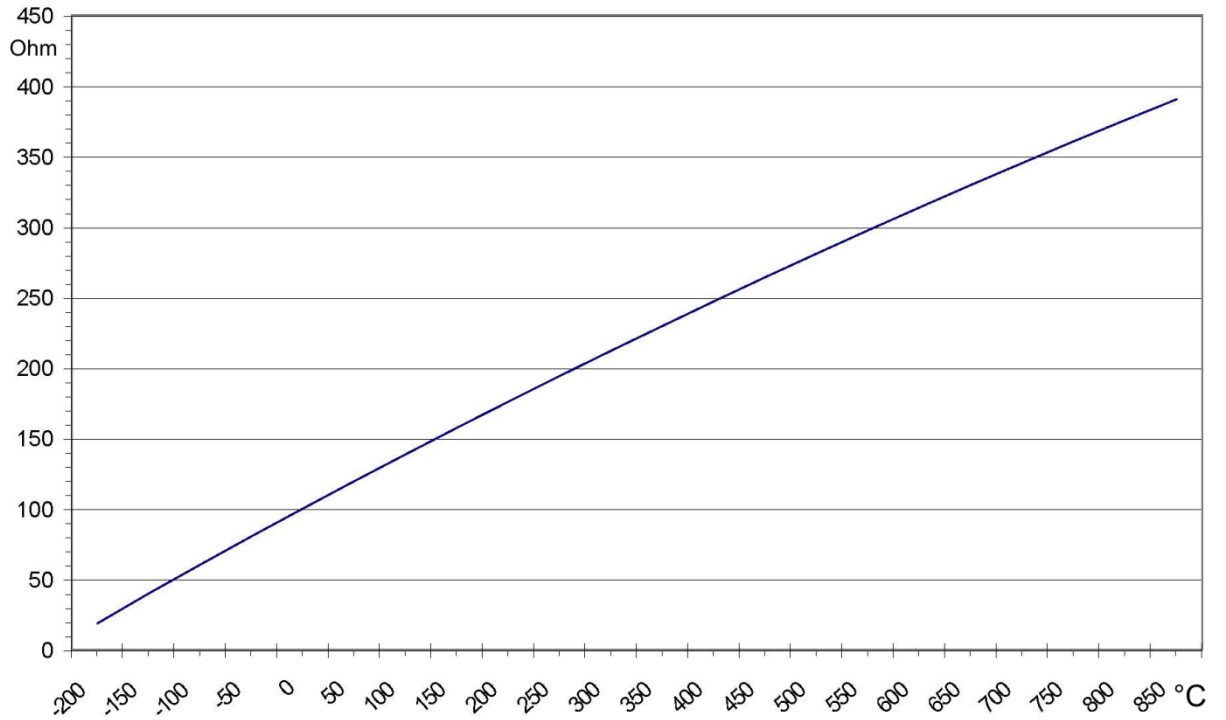

Figure 3-46: Analog inputs - characteristics diagram Pt100

Temp. [°C]	-200	-150	-100	-50	0	10	20	30	40	50	60
Temp. [°F]	-328	-238	-148	-58	32	50	68	86	104	122	140
R [Ohm]	18.5	39.7	60.25	80.7	100	103.9	107.8	111.7	115.5	119.4	123.2
Temp. [°C]	70	80	90	100	125	150	175	200	225	250	300
Temp. [°F]	158	176	194	212	257	302	347	392	437	482	572
R [Ohm]	127.1	130.9	134.7	138.5	147.9	157.3	166.6	175.8	188.6	194.1	212.0
Temp. [°C]	350	400	450	500	550	600	650	700	750	800	850
Temp. [°F]	662	752	842	932	1022	1112	1202	1292	1382	1472	1562
R [Ohm]	229.7	247.0	264.1	280.9	297.4	313.6	329.5	345.1	360.5	375.5	390.25

Table 3-129: Analog inputs - characteristics diagram Pt100

Appendix G. LDSS Formulas



The following formulas are used by the load-dependent start/stop function to determine whether a genset is to be started or stopped.

Abbreviations



$P_{GN \text{ real active}}$	Momentary active generator real power on the busbar
$P_{\text{rated active}}$	Momentary active generator rated power on the busbar
P_{reserve}	$P_{\text{rated active}} - P_{GN \text{ real active}}$
$P_{\text{reserve isolated}}$	Parameter 5760; minimum permissible reserve power on busbar in isolated operation
$P_{\text{hysteresis IOP}}$	Parameter 5761; hysteresis in isolated operation
$P_{MN \text{ setpoint}}$	Export / import power control setpoint
$P_{MN \text{ real}}$	Momentary active power at the interchange point
$P_{MOP \text{ minimum}}$	Parameter 5767; minimum requested generator load
$P_{\text{reserve parallel}}$	Parameter 5768; minimum permissible reserve power on busbar in mains parallel operation
$P_{\text{hysteresis MOP}}$	Parameter 5769; hysteresis in mains parallel operation
$P_{\text{max. load isolated}}$	Parameter 5762; maximum permissible generator load in isolated operation
$P_{\text{min. load isolated}}$	Parameter 5763; minimum permissible generator load in isolated operation
$P_{\text{max. load parallel}}$	Parameter 5770; maximum permissible generator load in mains parallel operation
$P_{\text{min. load parallel}}$	Parameter 5771; minimum permissible generator load in mains parallel operation

LDSS Mode Reserve Power



Isolated Operation

Changing the Engine Combination to Increase Rated Power

$$P_{GN \text{ real active}} + P_{\text{reserve isolated}} > P_{\text{rated active}}$$

Changing the Engine Combination to Reduce Rated Power

$$P_{GN \text{ real active}} + P_{\text{reserve isolated}} + P_{\text{hysteresis IOP}} < P_{\text{rated active}}$$

Mains Parallel Operation (Import/Export Control)

Starting the First Engine Combination (no engine supplies the busbar)

$$P_{MN \text{ setpoint}} - P_{MN \text{ real}} + P_{GN \text{ real active}} > P_{MOP \text{ minimum}}$$

Changing the Engine Combination to Increase Rated Power

$$P_{MN \text{ setpoint}} - P_{MN \text{ real}} + P_{GN \text{ real active}} + P_{\text{reserve parallel}} > P_{\text{rated active}}$$

Changing the Engine Combination to Reduce Rated Power

$$P_{MN \text{ setpoint}} - P_{MN \text{ real}} + P_{GN \text{ real active}} + P_{\text{reserve parallel}} + P_{\text{hysteresis MOP}} < P_{\text{rated active}}$$

Stopping the Last Engine Combination (load close to minimum load)

$$P_{MN \text{ setpoint}} - P_{MN \text{ real}} + P_{GN \text{ real active}} < P_{MOP \text{ minimum}} - P_{\text{hysteresis MOP}}$$

LDSS Mode Generator Load



Isolated Operation

Changing the Engine Combination to Increase Rated Power

$$P_{GN \text{ real active}} > P_{\text{max. load isolated}}$$

Changing the Engine Combination to Reduce Rated Power (except dynamic set point is not matched)

$$P_{GN \text{ real active}} < P_{\text{min. load isolated}}$$

Mains Parallel Operation (Import/Export Control)

Starting the First Engine Combination (no engine supplies the busbar)

$$P_{MN \text{ setpoint}} - P_{MN \text{ real}} + P_{GN \text{ real active}} > P_{MOP \text{ minimum}}$$

Changing the Engine Combination to Increase Rated Power

$$P_{GN \text{ real active}} > P_{\text{max. load parallel}}$$

Changing the Engine Combination to Reduce Rated Power (except dynamic set point is not matched)

$$P_{GN \text{ real active}} < P_{\text{min. load parallel}}$$

Stopping the Last Engine Combination (load close to minimum load)

$$P_{MN \text{ setpoint}} - P_{MN \text{ real}} + P_{GN \text{ real active}} < P_{MOP \text{ minimum}} - P_{\text{hysteresis MOP}}$$

LDSS Dynamic



$$\text{Dynamic characteristic} = [(\text{max. generator load} - \text{min. generator load}) * \text{dynamic}] + (\text{min. generator load})$$

$$\text{Dynamic power level} = (\text{dynamic characteristic}) * (\text{generator rated power})$$

Constants:

Low dynamic = 25 %

Moderate dynamic = 50 %

High dynamic = 75 %

Example for Moderate dynamic:

$$\text{Dynamic characteristic} = [(80 \% - 40 \%) * 50 \%) + (40 \%) = 60 \%$$

$$\text{Dynamic power level} = (60 \%) * (200 \text{ kW}) = 120 \text{ kW}$$

Appendix H. Service Options



Product Service Options



The following factory options are available for servicing Woodward equipment, based on the standard Woodward Product and Service Warranty (5-01-1205) that is in effect at the time the product is purchased from Woodward or the service is performed. If you are experiencing problems with installation or unsatisfactory performance of an installed system, the following options are available:

- Consult the troubleshooting guide in the manual.
- Contact Woodward technical assistance (see "How to Contact Woodward" later in this chapter) and discuss your problem. In most cases, your problem can be resolved over the phone. If not, you can select which course of action you wish to pursue based on the available services listed in this section.

Returning Equipment For Repair



If a control (or any part of an electronic control) is to be returned to Woodward for repair, please contact Woodward in advance to obtain a Return Authorization Number. When shipping the unit(s), attach a tag with the following information:

- name and location where the control is installed;
- name and phone number of contact person;
- complete Woodward part numbers (P/N) and serial number (S/N);
- description of the problem;
- instructions describing the desired type of repair.



CAUTION

To prevent damage to electronic components caused by improper handling, read and observe the precautions in Woodward manual 82715, *Guide for Handling and Protection of Electronic Controls, Printed Circuit Boards, and Modules*.

Packing A Control

Use the following materials when returning a complete control:

- protective caps on any connectors;
- antistatic protective bags on all electronic modules;
- packing materials that will not damage the surface of the unit;
- at least 100 mm (4 inches) of tightly packed, industry-approved packing material;
- a packing carton with double walls;
- a strong tape around the outside of the carton for increased strength.

Return Authorization Number RAN

When returning equipment to Woodward, please telephone and ask for the Customer Service Department in Stuttgart [+49 (0) 711 789 54-0]. They will help expedite the processing of your order through our distributors or local service facility. To expedite the repair process, contact Woodward in advance to obtain a Return Authorization Number, and arrange for issue of a purchase order for the unit(s) to be repaired. No work can be started until a purchase order is received.



NOTE

We highly recommend that you make arrangement in advance for return shipments. Contact a Woodward customer service representative at +49 (0) 711 789 54-0 for instructions and for a Return Authorization Number.

Replacement Parts



When ordering replacement parts for controls, include the following information:

- the part numbers P/N (XXXX-XXX) that is on the enclosure nameplate;
- the unit serial number S/N, which is also on the nameplate.

How To Contact Woodward



Please contact following address if you have questions or if you want to send a product for repair:

Woodward GmbH
Handwerkstrasse 29
70565 Stuttgart - Germany

Phone: +49 (0) 711 789 54-0 (8.00 - 16.30 German time)
Fax: +49 (0) 711 789 54-100
e-mail: stgt-info@woodward.com

For assistance outside Germany, call one of the following international Woodward facilities to obtain the address and phone number of the facility nearest your location where you will be able to get information and service.

Facility	Phone number
USA	+1 (970) 482 5811
India	+91 (129) 409 7100
Brazil	+55 (19) 3708 4800
Japan	+81 (476) 93 4661
The Netherlands	+31 (23) 566 1111

You can also contact the Woodward Customer Service Department or consult our worldwide directory on Woodward's website (www.woodward.com) for the name of your nearest Woodward distributor or service facility. [For worldwide directory information, go to www.woodward.com/ic/locations.]

Engineering Services



Woodward Industrial Controls Engineering Services offers the following after-sales support for Woodward products. For these services, you can contact us by telephone, by e-mail, or through the Woodward website.

- Technical support
- Product training
- Field service during commissioning

Technical Support is available through our many worldwide locations, through our authorized distributors, or through GE Global Controls Services, depending on the product. This service can assist you with technical questions or problem solving during normal business hours. Emergency assistance is also available during non-business hours by phoning our toll-free number and stating the urgency of your problem. For technical engineering support, please contact us via our toll-free or local phone numbers, e-mail us, or use our website and reference technical support.

Product Training is available on-site from several of our worldwide facilities, at your location, or from GE Global Controls Services, depending on the product. This training, conducted by experienced personnel, will assure that you will be able to maintain system reliability and availability. For information concerning training, please contact us via our toll-free or local phone numbers, e-mail us, or use our website and reference *customer training*.

Field Service engineering on-site support is available, depending on the product and location, from our facility in Colorado, or from one of many worldwide Woodward offices or authorized distributors. Field engineers are experienced on both Woodward products as well as on much of the non-Woodward equipment with which our products interface. For field service engineering assistance, please contact us via our toll-free or local phone numbers, e-mail us, or use our website and reference *field service*.

Technical Assistance



If you need to telephone for technical assistance, you will need to provide the following information. Please write it down here before phoning:

Contact

Your company _____

Your name _____

Phone number _____

Fax number _____

Control (see name plate)

Unit no. and revision: P/N: _____ REV: _____

Unit type easYgen- _____

Serial number S/N _____

Description of your problem

Please be sure you have a list of all parameters available. You can print this using ToolKit. Additionally you can save the complete set of parameters (standard values) and send them to our Service department via e-mail.

We appreciate your comments about the content of our publications.
Please send comments to: stgt-documentation@woodward.com
Please include the manual number from the front cover of this publication.



Woodward GmbH
Handwerkstrasse 29 - 70565 Stuttgart - Germany
Phone +49 (0) 711 789 54-0 • Fax +49 (0) 711 789 54-100
stgt-info@woodward.com

Homepage

<http://www.woodward.com/power>

Woodward has company-owned plants, subsidiaries, and branches, as well as authorized distributors and other authorized service and sales facilities throughout the world.

Complete address/phone/fax/e-mail information for all locations is available on our website (www.woodward.com).

2010/06/Stuttgart