

3103 Gas Valve with EM-35MR Electric Powered Actuator

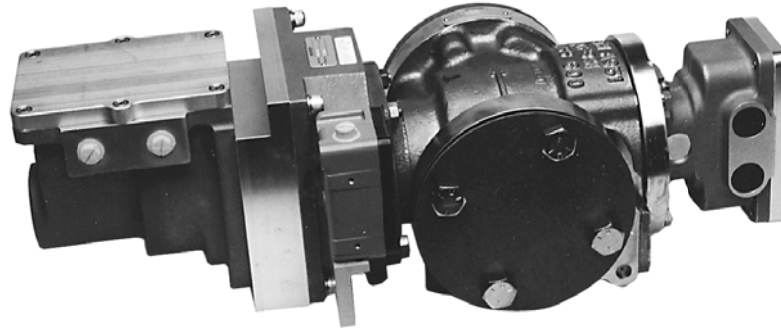

Applications

The 3103 gas valve is a stainless steel valve capable of metering gas flow between 23 kg/h and 18 144 kg/h (50 lb/h and 40 000 lb/h). It is designed to be corrosion resistant and self-cleaning, allowing it to operate in sour gas environments (high sulfur content gas) that can cause problems for other valves. When used in conjunction with an EM-35MR actuator and EM 24 V digital driver, the 3103 valve delivers the demanding accuracy needed for DLE applications.

The EM-35MR actuator is all electric, so hydraulic contamination and maintenance problems are eliminated. Cost is reduced since there is no HPU to maintain or replace. In addition, the EM-35MR actuator is designed for long life, although it may be replaced in the field if necessary.

Description

The 3103 gas valve is a rotary sleeve-and-shoe type throttling valve. The metering port area is determined by input shaft position from the actuator. Valve position feedback to the actuator driver is accomplished using a high accuracy resolver. The EM-35MR actuator is designed for use with the EM 24 V digital driver. The motor is a brushless dc motor with a motor clutch and gearhead assembly. The motor uses Samarium Cobalt permanent magnets bonded and sleeved to the rotor element. Rotor position sensing is performed through the use of a resolver.

Features

The EM-35MR motor assembly is housed in a cast aluminum, explosion-proof housing. A thermal potting compound is used to transfer heat generated by the motor to the cast housing and out to the ambient environment. The motor output shaft is directly coupled to the valve input shaft through the use of a stainless steel torsional coupling.

EM 24 V Digital Driver

The driver contains an analog position controller that receives a demand signal via a (4 to 20) mA input. The feedback signal is generated by a brushless resolver that is mounted on the fuel metering valve. The driver contains fault detection circuitry which provides the status of the (4 to 20) mA interface, position controller, driver, and feedback to the shutdown logic. A fault condition or an external shutdown command will disable the output (removing power to the motor), which in turn causes the valve return spring to close the valve.

This driver, designed for use with a Woodward NetCon[®] or MicroNet[™] control system, consists of a real-time SIO and a driver. The real-time SIO and the digital driver exchange information over a serial communication line. The digital form of the data preserves the 16-bit feedback resolution necessary to meet the system accuracy requirements. The real-time SIO is configured during the system initialization with data selected off-line by the GAP[™] (Graphical Application Program) software.

- Highly accurate
- Ideal for demanding DLE applications
- All electric
- Low maintenance
- Designed for long life
- Integral part of the total turbine control system
- Models are available with certifications for North American Hazardous Locations
- Models are available compliant with the applicable CE Directives – ATEX, Pressure Equipment, Machinery, EMC

3103 Gas Valve Specifications

SUPPLY CHARACTERISTICS

Contaminants

Solid particles
 <10 µm diameter 30 ppm by volume maximum
 >10 µm diameter 0.3 ppm by volume maximum

Metered Fuel Types

Natural, propane, methane service

Specific Gravity

0.5 to 1.05

Temperature

(-40 to +149) °C / (-40 to +300) °F
 (-29 to +149) °C / (-20 to +300) °F (restriction for CE Marking)

GAS FLOW REQUIREMENTS

Inlet Pressure

6205 kPa (900 psia) maximum
 4964 kPa (720 psia) maximum (restriction for CE Marking)

Pressure Differential

(172 to 6205) kPa / (25 to 900) psi

Gas Flow Range

(23 to 18144) kg/h / (50 to 40000) lb/h (0.6 sp gr) maximum
 flow capacity is dependent upon available gas conditions

Accuracy Standard

+5 % of point, or +0.25 % of maximum flow, whichever is larger

High Accuracy Dry Low Emissions Applications

2 % of point (consult Woodward)

EM-35MR Actuator

MECHANICAL

Output Shaft Rotation

60° (rotation limited by valve stops)

Continuous Output Torque

+24.9 N·m (+220 lb-in) maximum

Peak Output Torque

+62.4 N·m (+552 lb-in) minimum

ELECTRICAL

Power Input

28 V (dc) nominal
 (18 to 32) V (dc) operating

Current

37 A, maximum for 50 ms
 15 A, maximum continuous

PERFORMANCE

Slew Rate

150 ms to open the valve and 80 ms to close the valve
 (internal spring adding) at a nominal line voltage of 28 V (dc)

Bandwidth

>5 Hz

Position Accuracy

0.50° analog
 0.10° digital

Regulatory Compliance

European Compliance for CE Marking:

These listings are limited only to those units bearing the CE Marking. Compliance with the European regulations is the result of compliance of the individual components:

EMC Directive: Declared to 89/336/EEC COUNCIL DIRECTIVE of 03 May 1989 on the approximation of the laws of the Member States relating to electromagnetic compatibility.

Pressure Equipment Directive: Certified to Pressure Equipment Directive 97/23/EC of 29 May 1997 on the approximation of the laws of the Member States concerning pressure equipment, Category II

ATEX – Potentially Explosive Atmospheres Directive: Declared to 94/9/EC COUNCIL DIRECTIVE of 23 March 1994 on the approximation of the laws of the Member States concerning equipment and protective systems intended for use in potentially explosive atmospheres.

EM 24 V Digital Driver: DEMKO 02 ATEX 152309
 Zone 2, Category 3, Group II G, EEx nL IIC T4 at 68 °C ambient

EM Resolver: LCIE 02 ATEX 6141 X

EM-35MR

Actuator: LCIE 02 ATEX 6140 X
 Zone 1, Category 2, Group II G, EEx d IIB T3

Special Conditions for Safe Use:

Operating ambient temperature from -29 °C to +149 °C (restriction for CE Marking).

Use supply wires suitable for a maximum ambient temperature of +149 °C.

The Minimum Position Switch option is not available for use in an ATEX environment.

Other European Compliance:

Compliance with the following European Directives or standards does not qualify this product for application of the CE Marking:

Machinery Directive: Compliant as a component with 98/37/EC COUNCIL DIRECTIVE of 23 July 1998 on the approximation of the laws of the Member States relating to machinery.

North American Compliance:

Suitability for use in North American Hazardous Locations is the result of compliance of the individual components:

EM-35MR Actuator: CSA Certified for Class I, Division 1, Groups C & D, Class I, Division 2, Groups B, C, D, T3 at 149 °C Ambient. For use in Canada and the United States.

EM Resolver: CSA Certified for Class I, Division 1, Groups C & D, Class I, Division 2, Groups B, C, D, T3 at 150 °C Ambient. For use in Canada and the United States.

EM 24 V Digital Driver: UL Listed for Class I, Division 2, Groups A, B, C, D, T4 at 68 °C Ambient. For use in Canada and the United States.

Minimum Position Switch: CSA Certified for Class I, Division 1, Groups C & D. For use in Canada.
 UL Listed for Class I, Division 1, Groups C & D. For use in the United States.

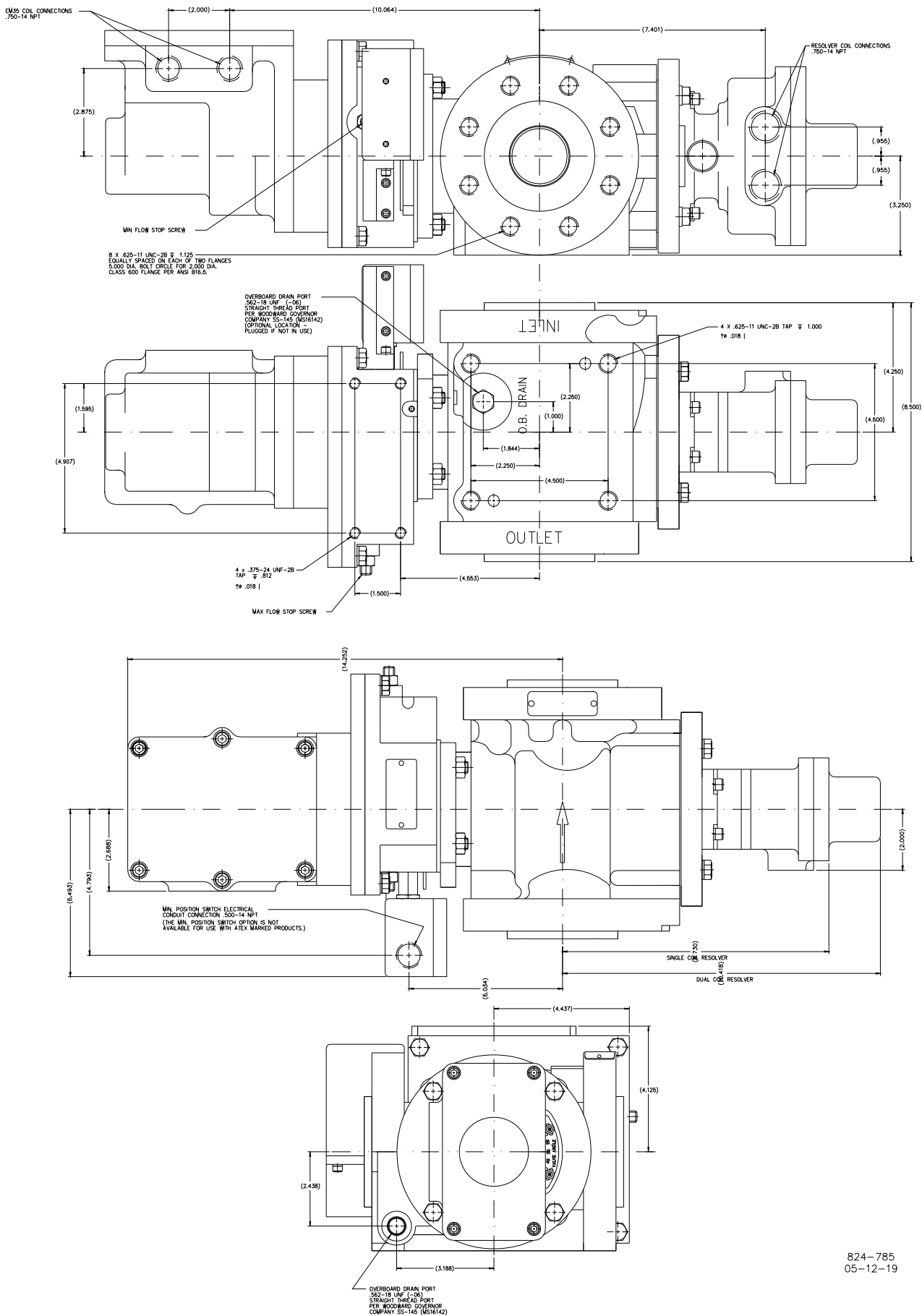

Outline Drawing of EM-35MR Actuator/3103 Gas Valve
(Do not use for construction)

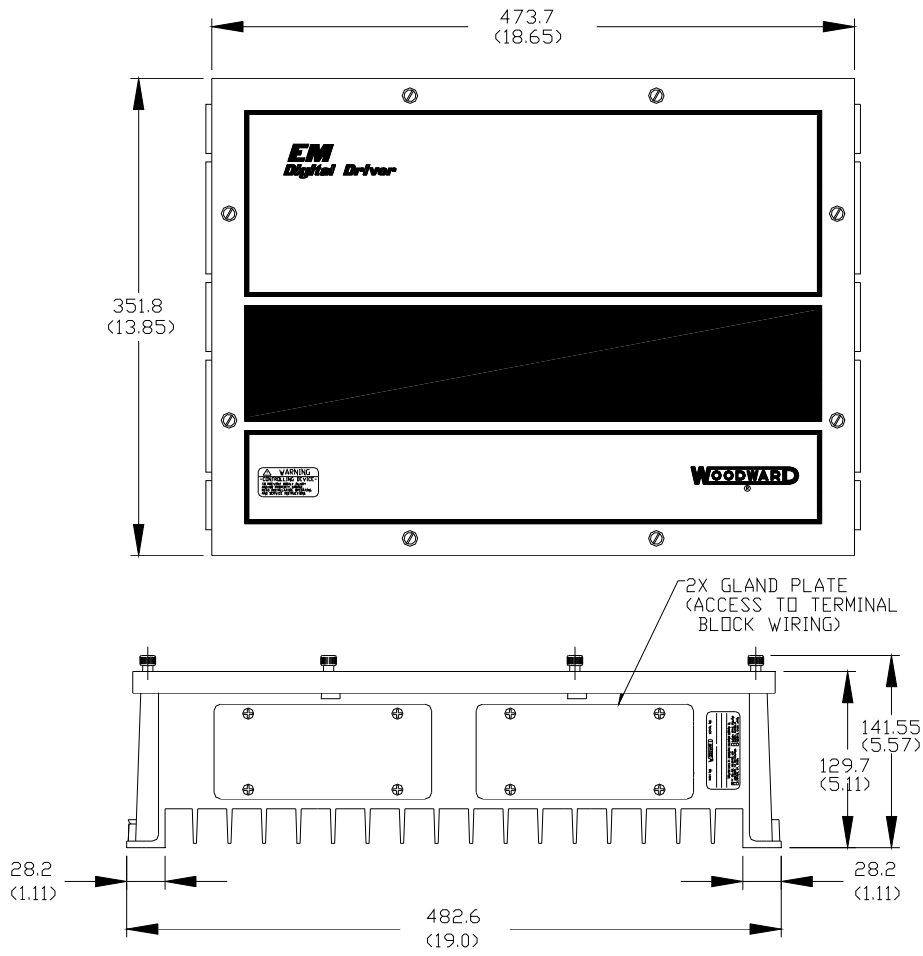

400-321a
98-09-30 JMM/skw

Dimensions of Driver Box
(Do not use for construction)

Technical Manual 40185



PO Box 1519, Fort Collins CO, USA 80522-1519
1000 East Drake Road, Fort Collins CO 80525
Tel.: +1 (970) 482-5811 ♦ Fax: +1 (970) 498-3058
www.woodward.com

Distributors & Service

Woodward has an international network of distributors and service facilities. For your nearest representative, call the Fort Collins plant or see the Worldwide Directory on our website.

This document is distributed for informational purposes only. It is not to be construed as creating or becoming part of any Woodward contractual or warranty obligation unless expressly stated in a written sales contract.

© Woodward 1999, All Rights Reserved

For more information contact:

2011/9/Colorado