

Magnetic Pickups

SAE THREADS

3/8-24 Pickup DYNT 17000 Series

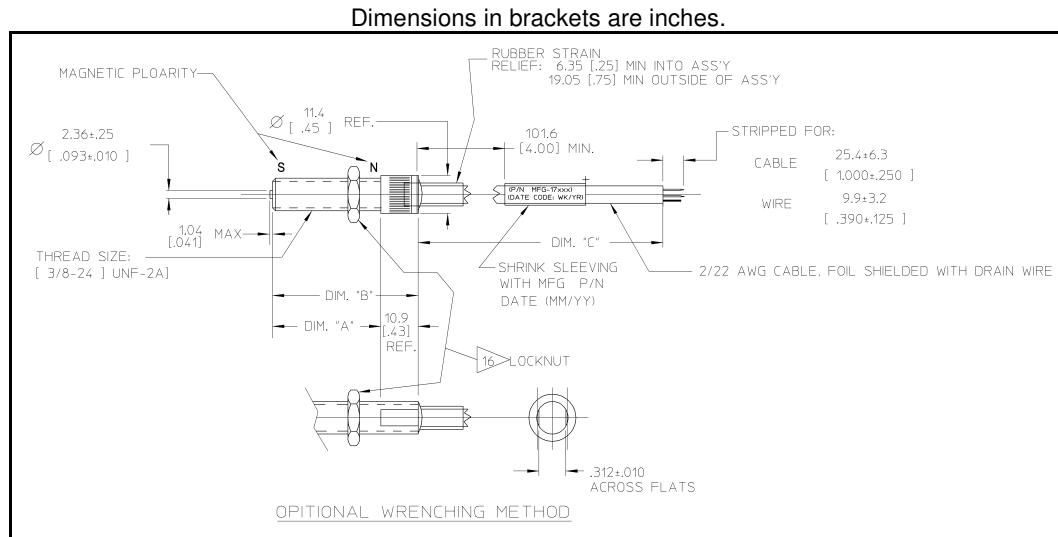

Figure 1. DYNT 17000 Series Dimensions

FIGURE 1 NOTES

Note 16 Hex jam-nut

Size: 14.27mm (0.562") across flats; thickness 4.5 / 5.1mm (0.180" / 0.200")

Material to be:

- 1) Corrosion resistant steel
- 2) Zinc plated steel with supplemental clear chromate dip
- 3) Zinc plated brass with supplemental clear chromate dip

Specifications & Dimensions

PART NUMBER	OUTPUT VOLTAGE *	RESISTANCE (MAXIMUM)	DIMENSIONS		
			Dim. A	Dim. B	Dim. C
DYNT-17100	3.6 V	100,000 Ohms	25.40mm (1.00")	36.32mm (1.43")	1828.8mm (72.00")
DYNT-17150	3.6 V	100,000 Ohms	42.54mm (1.68")	53.34mm (2.10")	1828.8mm (72.00")
DYNT-17200	3.6 V	100,000 Ohms	57.66mm (2.27")	68.58mm (2.70")	1828.8mm (72.00")
DYNT-17400	3.6 V	100,000 Ohms	101.60mm (4.0")	112.52mm (4.43")	1828.8mm (72.00")

(*) Tested at surface speed of 280 inches/second with a 20-pitch, 60-tooth gear at 0.025 (0.635) air gap and a resistive load of 100,000 Ohms

Temperature Range:

-100°F to +225°F (-73.3°C to +107.2°C)

Polarity:

Red or white lead to go positive when magnetic flux linkage is increased

Case:

Non-magnetic stainless steel

Sealing:

Capable of functioning immersed in motor oil or diesel fuel.

Capable of functioning in 95% humidity.

5/8-18 Pickup DYNT 10000 Series & 15000 Series

Dimensions in brackets are inches.

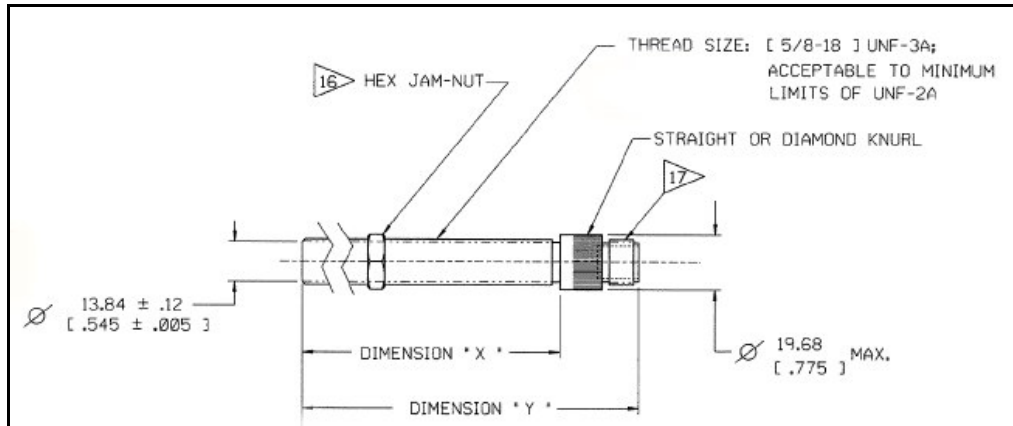

Figure 2. DYNT Series 10000 and Series 15000 Dimensions

FIGURE 2 NOTES

Note 16 Hex jam-nut

Size: 19.05 mm (0.75") across flats;
thickness 5.1 / 6.6 mm (0.200" / 0.260")

Material to be:

- 1) Corrosion resistant steel
- 2) Zinc plated steel with supplemental clear chromate dip
- 3) Zinc plated brass with supplemental clear chromate dip

Note 17 Output connector

Connector to mate with MS3106A 10SL-4S connector or equivalent (see Figure 8)

Note: Material for the straight or diamond knurl barrel is non-magnetic stainless steel or aluminum

Specifications & Dimensions

PART NUMBER	OUTPUT VOLTAGE *		RESISTANCE (MAXIMUM)		DIMENSIONS	
	3.6V	10V	250 Ohms	1200 Ohms	Dim. X	Dim. Y
DYNT-10100	●		●		63.5 mm (2.5")	91.4 mm (3.6")
DYNT-10200	●		●		101.6 mm (4.0")	129.5 mm (5.1")
DYNT-15200		●		●		
DYNT-10300	●		●		25.4 mm (1.0")	53.3 mm (2.1")
DYNT-10400	●		●		76.2 mm (3.0")	104.1 mm (4.1")
DYNT-15400		●		●		
DYNT-10500	●		●		152.4 mm (6.0")	180.3 mm (7.1")
DYNT-10600	●		●		127.0 mm (5.0")	154.9 mm (6.1")
DYNT-15600		●		●		

(*) Tested at surface speed of 280 inches/second with a 20-pitch, 60-tooth gear at 0.025 (0.635) air gap and a resistive load of 100,000 Ohms

Temperature Range:

-100 °F to +225 °F (-73.3 °C to +107.2 °C)

Polarity:

Pin "B" to go positive when magnetic flux linkage is increased

Case:

Non-magnetic stainless steel

Sealing:

Sealed to withstand 3 psi (20.68 Kpa) applied at tip end with no leakage out connector or lead end.

Capable of functioning immersed in motor oil or diesel fuel.

Capable of functioning in 95% humidity.

5/8-18 Pickup with Leads DYNT 12000 Series

Dimensions in brackets are inches.

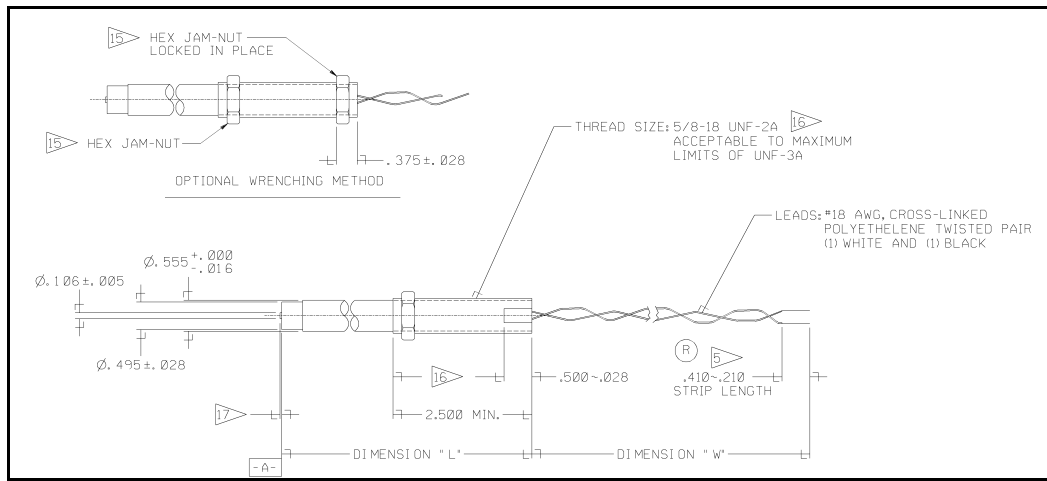

Figure 3. DYNT 12000 Series Dimensions

FIGURE 3 NOTES

Note 15 Hex jam-nut

Size: 19.05mm (0.750”) across flats;
thickness 5.1 / 6.6mm (0.200” / 0.260”)

Material to be:

- 1) Corrosion resistant steel
- 2) Zinc plated steel with supplemental clear chromate dip
- 3) Zinc plated brass with supplemental clear chromate dip

Note 16

Thread size should be up to wrenching flats as shown

Note 17

The tip to be flush to ± 0.12mm (± 0.005”) from surface

Specifications & Dimensions

PART NUMBER	OUTPUT VOLTAGE *	RESISTANCE (MAXIMUM)	INDUCTANCE (MAXIMUM) †	DIMENSIONS		
				Dim. L	Dimension W	
					Min	Max
DYNT-12100	3.6V	385 Ohms	150 mH	72.70mm (3.00")	127.00mm (5.0")	—
DYNT-12200	3.6V	385 Ohms	150 mH	114.30mm (4.50")	127.00mm (5.0")	—
DYNT-12700	3.6V	385 Ohms	150 mH	114.30mm (4.50")	127.00mm (5.00")	—

(*) Tested at surface speed of 280 inches/second with a 20-pitch, 60-tooth gear at 0.025 (0.635) air gap and a resistive load of 100,000 Ohms

(†) @ 1000 Hz test frequency

Temperature Range:

-100°F to +225°F (-73.3°C to +107.2°C)

Case:

Non-magnetic stainless steel

Sealing:

Capable of functioning immersed in motor oil or diesel fuel.

Capable of functioning in 95% humidity.

3/4-16 Pickup with Leads DYNT 13000 Series

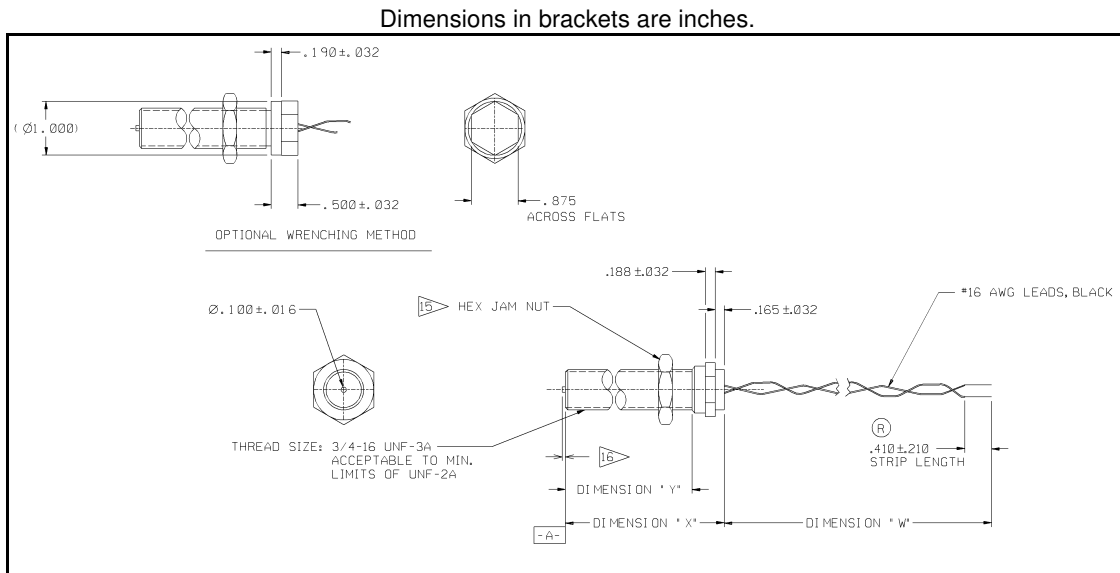

Figure 4. DYNT 13000 Series Dimensions

FIGURE 4 NOTES

Note 15 Hex jam-nut

Size: 28.5mm (1.125”) across flats;
thickness 5.1 / 6.6mm (0.200” / 0.260”)

Material to be:

- 1) Corrosion resistant steel
- 2) Zinc plated steel with supplemental clear chromate dip
- 3) Zinc plated brass with supplemental clear chromate dip

Note 16

The tip to be flush to ± 0.12mm (± 0.005”) from surface

Specifications & Dimensions

PART NUMBER	OUTPUT VOLTAGE *	RESISTANCE (MAXIMUM)	DIMENSIONS			
			Dim. X	Dim. Y	Dimension W	
					Min	Max
DYNT-13200	3.6 V	3575 Ohms	75.43mm (2.97")	60.20mm (2.37")	889.00mm (35.00")	939.80 mm (37.00")
DYNT-13300	3.6 V	3575 Ohms	99.06mm (3.90")	83.82mm (3.30")	889.00mm (35.00")	939.80 mm (37.00")
DYNT-13400	3.6 V	3575 Ohms	75.43mm (2.97")	60.20mm (2.37")	127.00mm (5.00")	—
DYNT-13500	3.6 V	3575 Ohms	99.06mm (3.90")	83.82mm (3.30")	127.00mm (5.00")	—

(*) Tested at surface speed of 280 inches/second with a 20-pitch, 60-tooth gear at 0.025 (0.635) air gap and a resistive load of 100,000 Ohms

Temperature Range:

-100°F to +225°F (-73.3°C to +107.2°C)

Polarity:

Pin "B" to go positive when magnetic flux linkage is increased

Case:

Non-magnetic with corrosion protective finish

Sealing:

Capable of functioning immersed in motor oil or diesel fuel.

Capable of functioning in 95% humidity.

3/4-16 Pickup w/Shielded Leads DYNT-19200

Dimensions in brackets are inches.

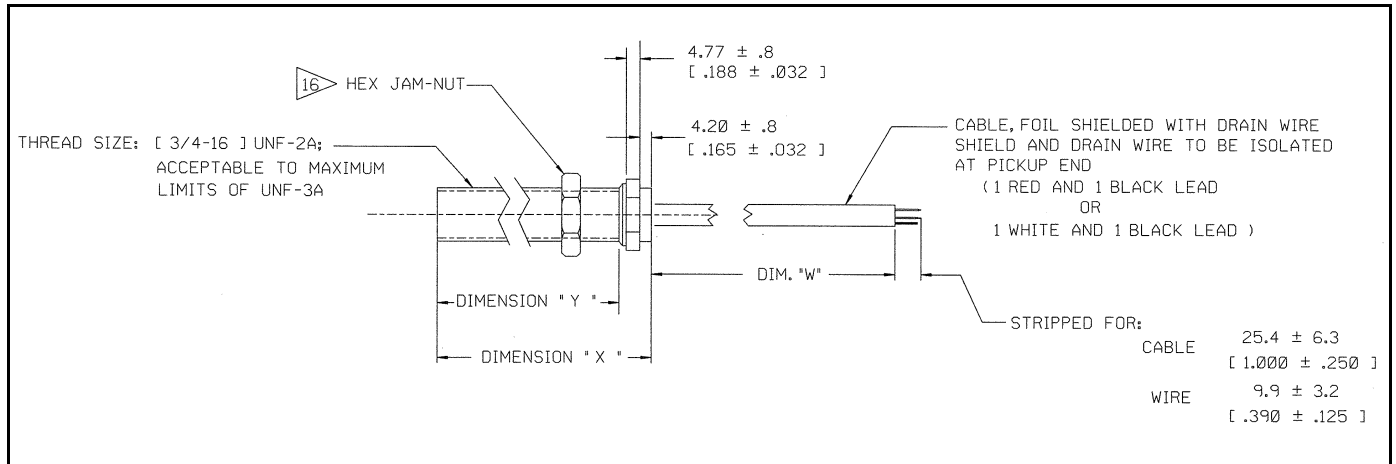
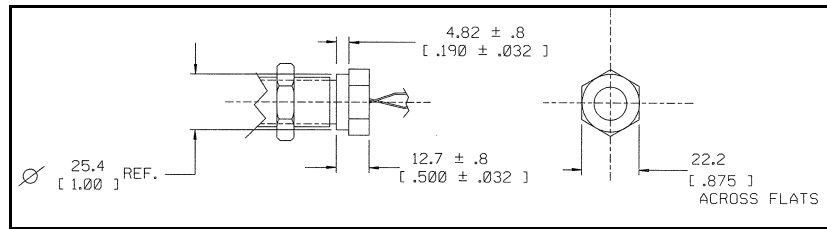

Figure 5. DYNT-19200 Dimensions



Optional Wrenching Method

FIGURE 5 NOTES

Note 16 Hex jam-nut

Size: 19.05mm (0.750") across flats; thickness 5.1 / 6.6mm (0.200" / 0.260")

Material to be:

- 1) Corrosion resistant steel
- 2) Zinc plated steel with supplemental clear chromate dip
- 3) Zinc plated brass with supplemental clear chromate dip

Specifications & Dimensions

PART NUMBER	OUTPUT VOLTAGE *	RESISTANCE (MAXIMUM)	DIMENSIONS		
			Dim. X	Dim. Y	Dim. W
DYNT-19200	3.6 V	3575 Ohms	75.43mm (2.97")	60.20mm (2.37")	1828.8mm (72.00")

(*) Tested at surface speed of 280 inches/second with a 20-pitch, 60-tooth gear at 0.025 (0.635) air gap and a resistive load of 100,000 Ohms

Temperature Range:

-100°F to +225°F (-73.3°C to +107.2°C)

Polarity:

Red or white lead to go positive when magnetic flux linkage is increased

Case:

Non-magnetic, with corrosion protective finish

Sealing:

Capable of functioning immersed in motor oil or diesel fuel.

Capable of functioning in 95% humidity.

M12 Pickup w/Leads DYNT 18100

Dimensions in brackets are inches.

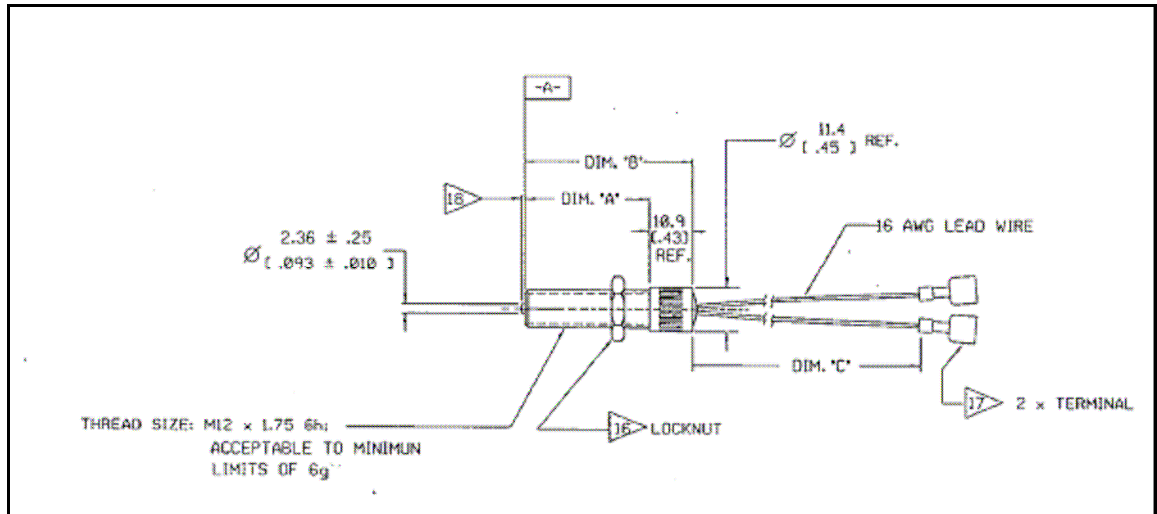

Figure 6. DYNT-18100 Dimensions

FIGURE 6 NOTES

Note 16 Hex jam-nut

Size: 19.05mm (0.75") across flats;
thickness 5.1 / 6.6mm (0.200" / 0.260")

Material to be:

- 1) Corrosion resistant steel
- 2) Zinc plated steel with supplemental clear chromate dip
- 3) Zinc plated brass with supplemental clear chromate dip

Note 17 Terminals

6.35mm (0.25") insulated tab terminal AMP p/n:
3-520107-2 or 3-520106-2
OR equivalent that will mate with AMP 6.35
(0.25) insulated receptacle terminal.

Note 18

The tip to be flush to ± 0.12mm (± 0.005") from surface

Specifications & Dimensions

PART NUMBER	OUTPUT VOLTAGE *	RESISTANCE (MAXIMUM)	DIMENSIONS		
	3.6V	1000 Ohms	Dim. A	Dim. B	Dim. C
DYNT-18100	●	●	70 mm (2.76")	88.39 mm (3.48")	40 mm (1.57")

(*) Tested at surface speed of 280 inches/second with a 20-pitch, 60-tooth gear at 0.025 (0.635) air gap and a resistive load of 100,000 Ohms

Temperature Range:

-100 °F to +225 °F (-73.3 °C to +107.2 °C)

Polarity:

Pin "B" to go positive when magnetic flux linkage is increased

Case:

Non-magnetic stainless steel

Sealing:

Capable of functioning immersed in motor oil or diesel fuel.

Capable of functioning in 95% humidity.

M16 Pickup DYNT 11000 Series & 16000 Series

Dimensions in brackets are inches.

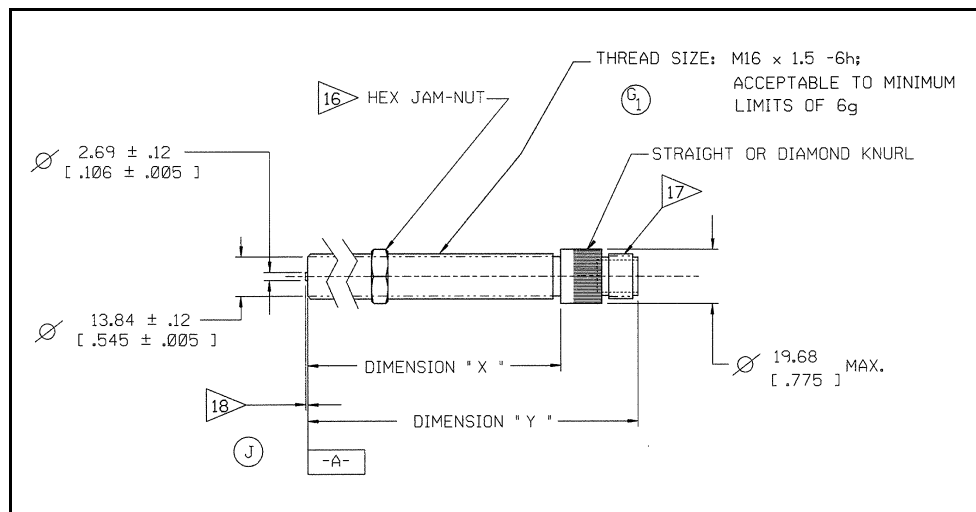
**Figure 7. DYNT Series 11000 and Series 16000 Dimensions****FIGURE 7 NOTES****Note 16 Hex jam-nut**

DYNT-11000 Series: Size: 24.00-23.67 mm (0.944-0.931") across flats;
thickness 8.00 / 7.42 mm (0.314" / 0.292")

DYNT-16000 Series: Size: 23.85 mm (0. 0.938") across flats;
thickness 5.1 / 6.6 mm (0.200" / 0.260")

Material to be:

- 1) Corrosion resistant steel
- 2) Zinc plated steel with supplemental clear chromate dip
- 3) Zinc plated brass with supplemental clear chromate dip

Note 17 Output connector

Connector to mate with MS3106A 10SL-4S connector
or equivalent (see Figure 8)

Note 18 Output connector

The tip to be flush to $\pm 0.12\text{mm}$ (± 0.005 ") from surface

Note: Material for the straight or diamond knurl barrel is
non-magnetic stainless steel or aluminum

M16 Pickup**Specifications & Dimensions**

PART NUMBER	OUTPUT VOLTAGE *		RESISTANCE (MAXIMUM)		DIMENSIONS	
	3.6V	10V	250 Ohms	1200 Ohms	Dim. X	Dim. Y
DYNT-11100	●		●		63.5 mm (2.5")	91.4 mm (3.6")
DYNT-16100		●		●		
DYNT-11200	●		●		101.6 mm (4.0")	129.5 mm (5.1")
DYNT-11300	●		●		25.4 mm (1.0")	53.3 mm (2.1")
DYNT-11400	●		●		76.2 mm (3.0")	104.1 mm (4.1")
DYNT-11500	●		●		152.4 mm (6.0")	180.3 mm (7.1")
DYNT-11600	●		●		127.0 mm (5.0")	154.9 mm (6.1")

(*) Tested at surface speed of 200 inches/second with a 20-pitch, 60-tooth gear at 0.025 (0.635) air gap and a resistive load of 100,000 Ohms

Temperature Range:

DYNT 11000 Series: -100°F to +248°F (-73.3°C to +120°C)

DYNT 16000 Series: -100°F to +225°F (-73.3°C to +107.2°C)

Polarity:

Pin "B" to go positive when magnetic flux linkage is increased

Case:

Non-magnetic stainless steel

Sealing:

Sealed to withstand 3 psi (20.68 Kpa) applied at tip end with no leakage out connector or lead end.

Capable of functioning immersed in motor oil or diesel fuel.

Capable of functioning in 95% humidity.

For DYNT Series magnetic pickup wire connections using MS-3106A-10SL-4S mating connector

Dimensions in brackets are inches.

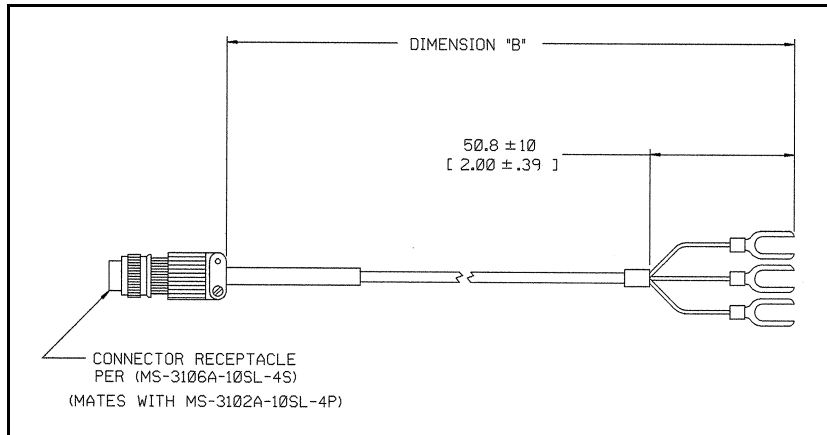
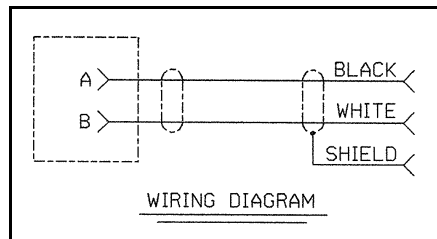

Figure 8. DK81-00X-0-00 Cable Harness Dimensions

PART NUMBER	DIMENSION B
DK81-001-0-00	3000.0 ± 51.0 mm (118.1 ± 2.0")
DK81-002-0-00	914.4 ± 51.0 mm (36.0 ± 2.0")
DK81-003-0-00	1524.0 ± 51.0 mm (60.0 ± 2.0")
DK81-007-0-00	4267.2 ± 51.0 mm (168.0 ± 2.0")
DK81-009-0-00	1066.8 ± 51.0 mm (42.0 ± 2.0")
DK81-010-0-00	1778.0 ± 51.0 mm (70.0 ± 2.0")



WARNING—OVERSPEED PROTECTION

The engine, turbine, or other type of prime mover should be equipped with an overspeed shutdown device to protect against runaway or damage to the prime mover with possible personal injury, loss of life, or property damage.

The overspeed shutdown device must be totally independent of the prime mover control system. An overtemperature or overpressure shutdown device may also be needed for safety, as appropriate.

INTERFACE SURFACE SELECTION

An optimum interface surface for either gears or flat disks with holes is essential for maximum voltage. **Figure 9** illustrates the ideal surface for gears; **Figures 10-12** illustrate surfaces for flat disks.

GEARS

In **Figure 9**, the optimum dimensions of A, B, C, and F are given as they relate to D—the diameter of pole piece of the magnetic pickup being used. The optimum relationship for maximum output is as follows:

- A. (dimension of top of tooth) equal to or greater than D
- B. (height of tooth) equal to or greater than C
- C. (space between teeth) equal to or greater than $3 \times D$
- D. diameter of pole piece
- E. (clearance) as close as possible; typically 0.38 ± 0.13 mm (0.015 ± 0.005 ")
- F. (gear thickness) equal to or greater than D

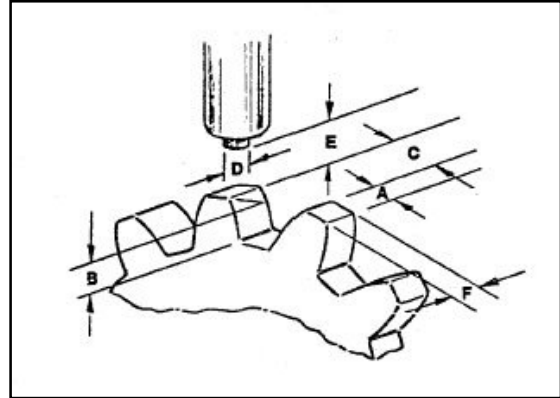

At times when maximum output is not required, a conventional stock gear can provide an output very close to the maximum if the tooth width (A) is equal to or greater than the pickup pole piece diameter (D). Gear thickness is not critical as long as it is equal to or greater than the pole piece diameter. For ease of alignment, the thickness should be two or three times the pole piece diameter. The spacing between the pole piece and any magnetic material between “dwell” periods should be equal to or greater than the pole piece diameter. These conditions are approximated when using a standard gear tooth having a diametral pitch of 8 or less. Such large tooth gears are necessary only when maximum output is desired.

FLAT DISKS

Figures 10-12 illustrate the various dimensional considerations when a flat disk is used with blind holes or through-holes drilled parallel to the shaft or with blind holes drilled perpendicular to the shaft. It is absolutely essential when using a disk with drilled holes that the holes be accurately spaced along the hole circle on the disk. Irregularly spaced holes will cause a phase shift in the magnetic pickup voltage with a resulting unwanted change in engine speed. The controller interprets the phase shift as a change in engine speed when actually it is not.)

In the figures below, the optimum dimensions of A, B, C, and E are given as they relate to D, the diameter of the pole piece of the magnetic pickup. (Dimension B does not apply in Figure 10.) The optimum relationship for maximum output is as follows:

- A. (space between holes) equal to or greater than D
- B. (depth of holes) equal to or greater than D
- C. (diameter of holes) equal to or greater than $3 \times D$
- D. (diameter of pole piece)
- E. (clearance) 0.38 ± 0.13 mm (0.015 ± 0.005 ")

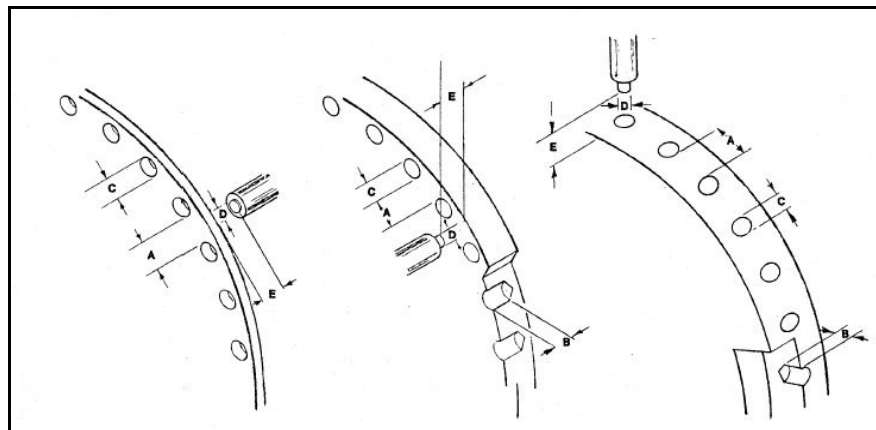

Figure 10

Figure 11

Figure 12

RELATED DOCUMENTATION

Product Specificaton 36533
5/8 and 3/4 Magnetic Pickups



PO Box 1519
Fort Collins CO, USA
80522-1519
1000 East Drake Road
Fort Collins CO 80525
Ph: +1 (970) 482-5811
Fax: +1 (970) 498-3058

Distributors & Service
Woodward has an international network of distributors and service facilities. For your nearest representative, call the Fort Collins plant or see the Worldwide Directory on our website.

Corporate Headquarters
Rockford IL, USA
Ph: +1 (815) 877-7441

www.woodward.com

This document is distributed for informational purposes only. It is not to be construed as creating or becoming part of any Woodward Governor Company contractual or warranty obligation unless expressly stated in a written sales contract.

© Woodward 2006
All Rights Reserved

06/07/M

For more information contact: