



PRODUCT FEATURES

- Flexible Helical Convolutions
- Easy Assembly and Repair
- 3/16 inch to 2 inch Diameter Systems
- Lightweight and Halogen Free Materials
- Unique Fittings Facilitate Field Polishing and Termination
- Environmentally Sealed Systems
- Crush Proof Designs
- Choose Discrete Components or Turnkey Assembly

Glenair Conduit Systems, Fittings and Bulk Tubing Protect Fiber Media from Mechanical and Environmental Damage

The Widest Range of Conduit Materials and Fittings in the Industry

Flexible, high-temperature convoluted tubing is an ideal material choice for the protection of fiber media. The material provides a durable, highly-flexible enclosure for fiber optic systems, with end-fittings and transitions to meet any installation configuration. The crush resistant, helical conduit comes in a range of standard diameters and wall thicknesses. Glenair's Gamma Processed ETFE tubing is constructed from thermally-stable ethylene tetrafluoroethylene. Other available materials include FEP, PFA, PTFE and halogen-free, light weight PEEK. Connector adapters, end-fittings and backshells for bulkhead termination of conduit to panels or junction boxes are also available.

Choose from Discrete Components or Turnkey Assembly

Glenair is uniquely positioned in the industry to offer not only fiber optic connectors, cables, termini and other discrete components, but also to provide turn-key assembly services. This capability is particularly strong in our assembly division. Glenair's fast turn-around assembly service leverages Glenair's vertically-integrated manufacturing facility. No matter what the challenge—from a custom, molded backshell to a composite junction box—Glenair is able to integrate our fiber optic conduit assemblies with a broad range of unique technologies. Factory termination of fiber optic media adds quality and reliability to the final interconnect system. And because Glenair has also developed our own line of in-house tooling and testing equipment, we are experts at delivering 100% inspected and tested assemblies—first time and every time. For more information on our conduit assemblies, consult the factory or visit us at www.glenair.com

**TYPE
A
TUBING
ONLY
NO BRAID**

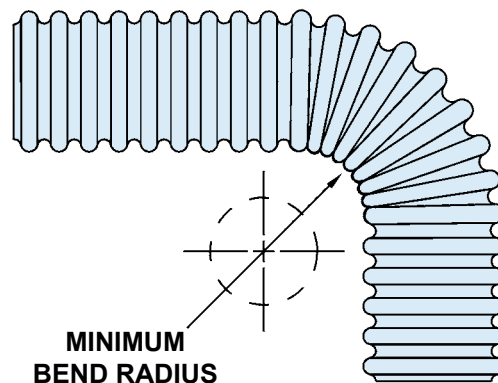
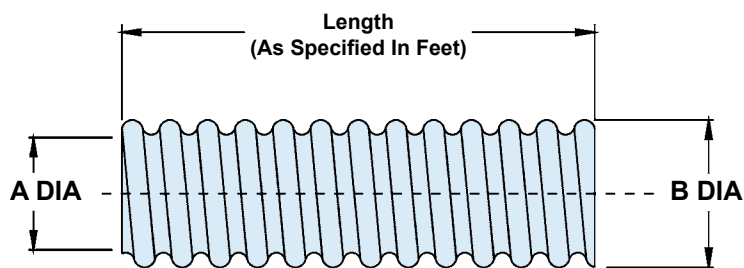
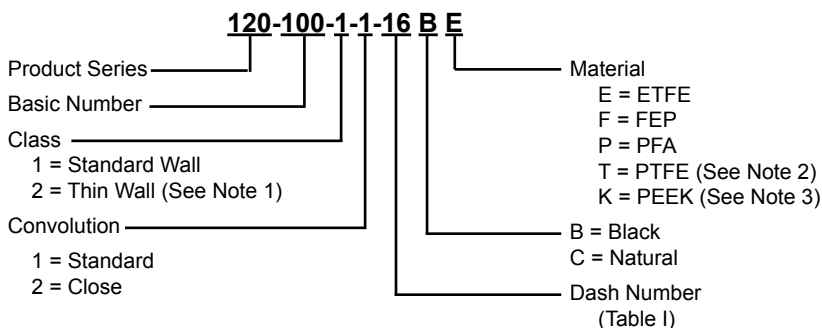

APPLICATION NOTES

1. Consult factory for thin-wall, close convolution combination.
2. Consult factory for PTFE maximum lengths.
3. Consult factory for PEEK min/max dimensions.
4. Metric dimensions (mm) are in parentheses.

TABLE I: TUBING SIZE				
Dash No.	Fractional Size Ref	A Inside Dia Min	B Dia Max	Minimum Bend Radius
06	3/16	.181 (4.6)	.320 (8.1)	.500 (12.7)
09	9/32	.273 (6.9)	.414 (10.5)	.750 (19.1)
10	5/16	.306 (7.8)	.450 (11.4)	.750 (19.1)
12	3/8	.359 (9.1)	.510 (13.0)	.880 (22.4)
14	7/16	.427 (10.8)	.571 (14.5)	1.000 (25.4)
16	1/2	.480 (12.2)	.650 (16.5)	1.250 (31.8)
20	5/8	.603 (15.3)	.770 (19.6)	1.500 (38.1)
24	3/4	.725 (18.4)	.930 (23.6)	1.750 (44.5)
28	7/8	.860 (21.8)	1.073 (27.3)	1.880 (47.8)
32	1	.970 (24.6)	1.226 (31.1)	2.250 (57.2)
40	1-1/4	1.205 (30.6)	1.539 (39.1)	2.750 (69.9)
48	1-1/2	1.437 (36.5)	1.832 (46.5)	3.250 (82.6)
56	1-3/4	1.688 (42.9)	2.156 (54.8)	3.630 (92.2)
64	2	1.937 (49.2)	2.332 (59.2)	4.250 (108.0)

120-103

Series 74 Helical Convoluted Tubing (MIL-T-81914)
 Natural or Black PFA, FEP, PTFE, Tefzel® (ETFE) or PEEK
 Type B - With External Black Dacron® Braid



Conduit and
 Conduit
 Systems

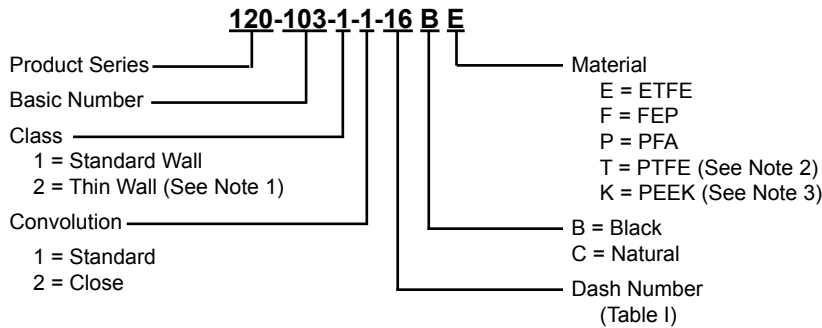

**TYPE
 B
 EXTERNAL
 BLACK
 DACRON®
 BRAID**

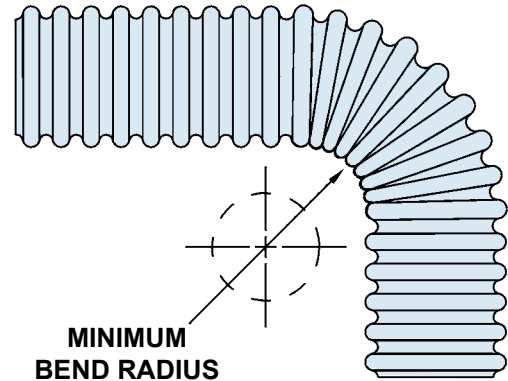
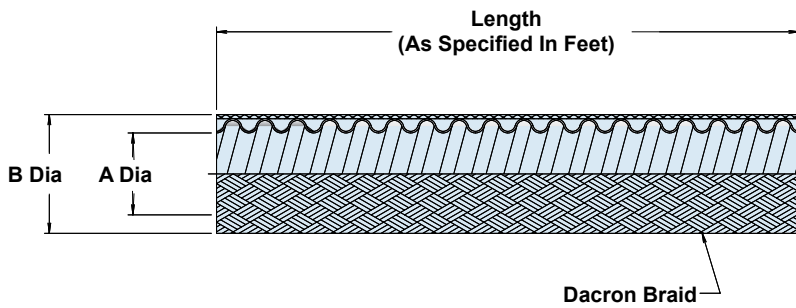

- APPLICATION NOTES**
1. Consult factory for thin-wall, close convolution combination.
 2. Consult factory for PTFE maximum lengths.
 3. Consult factory for PEEK min/max dimensions.
 4. Metric dimensions (mm) are in parentheses.

TABLE I: TUBING SIZE

Dash No.	Fractional Size Ref	A Inside Dia Min	B Dia Max	Minimum Bend Radius
06	3/16	.181 (4.6)	.430 (10.9)	.500 (12.7)
09	9/32	.273 (6.9)	.474 (12.0)	.750 (19.1)
10	5/16	.306 (7.8)	.510 (13.0)	.750 (19.1)
12	3/8	.359 (9.1)	.571 (14.6)	.880 (22.4)
14	7/16	.427 (10.8)	.631 (16.0)	1.000 (25.4)
16	1/2	.480 (12.2)	.710 (18.0)	1.250 (31.8)
20	5/8	.603 (15.3)	.830 (21.1)	1.500 (38.1)
24	3/4	.725 (18.4)	.990 (24.9)	1.750 (44.5)
28	7/8	.860 (21.8)	1.133 (28.8)	1.880 (47.8)
32	1	.970 (24.6)	1.286 (32.7)	2.250 (57.2)
40	1-1/4	1.205 (30.6)	1.599 (40.6)	2.750 (69.9)
48	1-1/2	1.437 (36.5)	1.892 (48.1)	3.250 (82.6)
56	1-3/4	1.688 (42.9)	2.192 (55.7)	3.630 (92.2)
64	2	1.937 (49.2)	2.442 (62.0)	4.250 (108.0)

189-014

Backshell for PEEK Convuluted Tubing to be used with MIL-PRF-28876 Fiber Optic Connectors

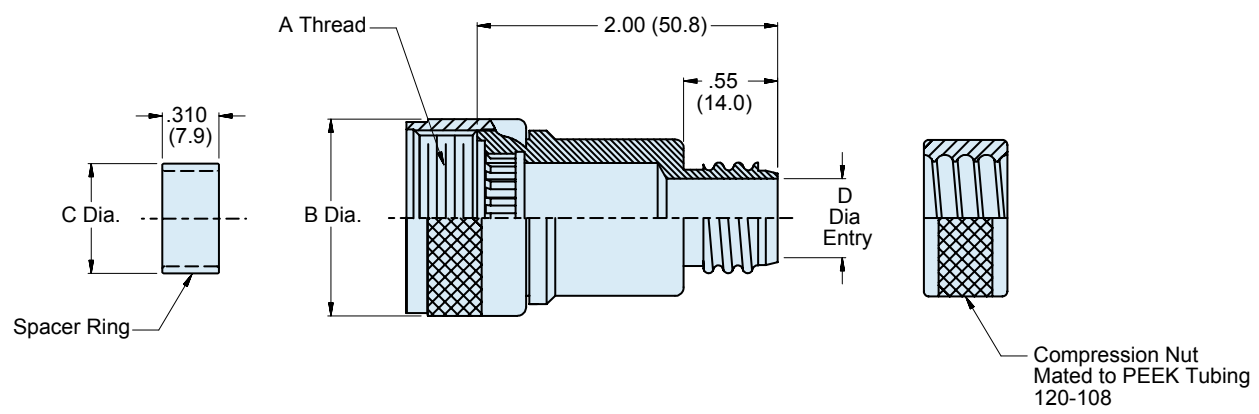
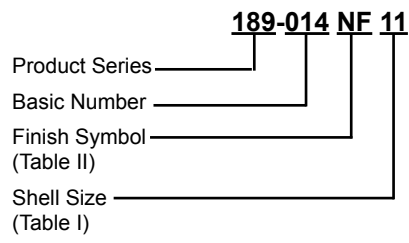

- ### APPLICATION NOTES
1. Assembly identified with manufacturer's name and P/N, space permitting.
 2. Material/ Finish:
Adapter, Coupling Nut, Ferrule, and Spacer Ring—See Table II.
 3. Spacer Ring is packaged loose and must be installed with connector at time of assembly to retain Terminus Insert.
 4. For 45° and 90° Backshell Option see Glenair drawing 189-021.
 5. Metric dimensions (mm) are indicated in parentheses.

189-014
Backshell for PEEK Convuluted Tubing
to be used with MIL-PRF-28876 Fiber Optic Connectors



TABLE I: SHELL SIZE

Shell Size	Connector Designator	A Thread CLASS 2B	B Dia. Max	C Dia. Max	D Dia Entry	PEEK Conduit Size Frac. Size	Dash No.
11	A	3/4 - 20 UNEF	.960 (10.4)	.410 (10.4)	.390 (9.9)	1/2	16
13	B	7/8 - 20 UNEF	1.085 (27.6)	.532 (13.5)	.390 (9.9)	1/2	16
15	C	1 - 20 UNEF	1.255 (31.9)	.710 (18.0)	.390 (9.9)	1/2	16
23	F	1 7/16 - 18 UNEF	1.695 (43.1)	1.116 (28.3)	.890 (22.6)	1	32

TABLE II: FINISH

SYM	MATERIAL	FINISH
NF	Aluminum	Cadmium/Olive Drab over Electroless Nickel (500 Hr. Salt Spray)
B	Aluminum	Cadmium Plate/Olive Drab
J	Aluminum	Gold Iridite over Cadmium Plate over Nickel
N	Aluminum	Cadmium Plate/Olive Drab over Nickel
M	Aluminum	Electroless Nickel
T	Aluminum	Cadmium Plate/Bright Dip over Nickel

189-038
Composite Connector Backshell Adapter
 for Helical Convoluted Tubing to be used with
MIL-DTL-38999 Series III & IV Fiber Optic Connectors

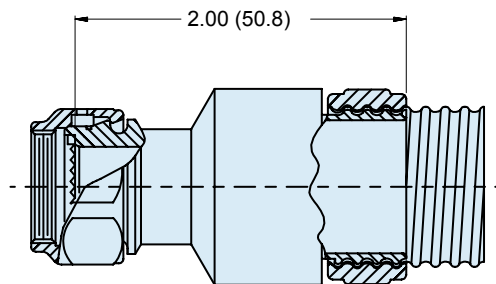
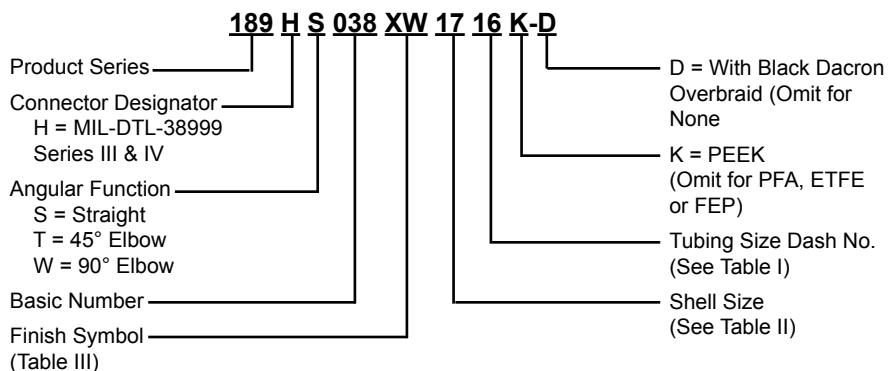

ONE PIECE SET UP

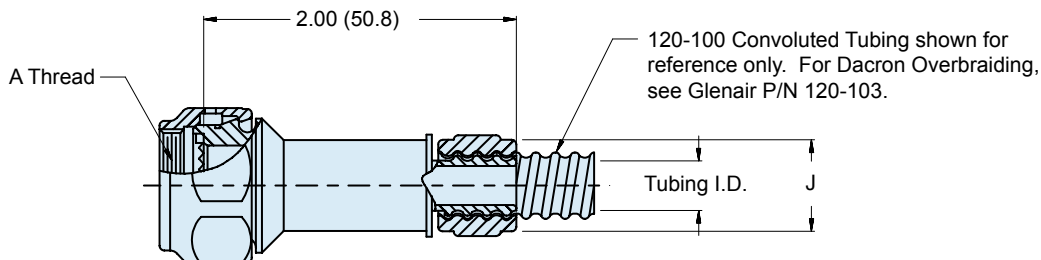

S - STRAIGHT

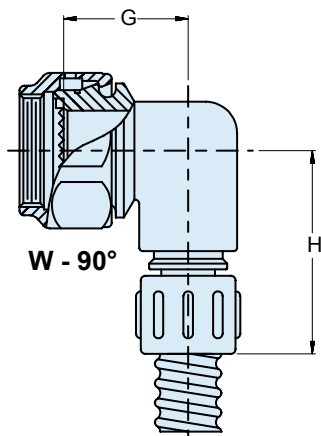

W - 90°

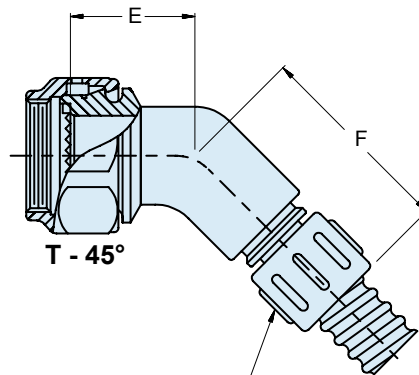

T - 45°

Knurl or Flute Style Mfr Option

189-038

**Composite Connector Backshell Adapter
for Helical Convolute Tubing to be used with
MIL-DTL-38999 Series III & IV Fiber Optic Connectors**



Conduit and
Conduit
Systems

TABLE I: TUBING SIZE

Dash No.	Conduit I.D.	J Dia Max
06	.188 (4.8)	.790 (20.1)
09	.281 (7.1)	.985 (25.0)
10	.312 (7.9)	.985 (25.0)
12	.375 (9.5)	1.035 (26.3)
14	.437 (11.1)	1.100 (27.9)
16	.500 (12.7)	1.160 (29.5)
20	.625 (15.9)	1.285 (32.6)
24	.750 (19.1)	1.480 (37.6)
28	.875 (22.2)	1.670 (42.4)
32	1.000 (25.4)	1.720 (43.7)
40	1.250 (31.8)	2.100 (53.3)
48	1.500 (38.1)	2.420 (61.5)

TABLE III: FINISH

SYM	MATERIAL	FINISH
XM	Composite	Electroless Nickel
XW	Composite	Cadmium Plate/Olive Drab over Electroless Nickel
XO	Composite	No Plating—Base Composite

TABLE II: SHELL SIZE

Shell Size	A Thread ISO Metric	E ±.060 (1.5)	F ±.090 (2.3)	G ±.060 (1.5)	H ±.090 (2.3)	Max Entry Max Tubing Size
11	M15 x 1 - 6H	.750 (19.1)	.950 (24.1)	.750 (19.1)	1.160 (29.5)	12
13	M18 x 1 - 6H	.750 (19.1)	1.020 (25.9)	.810 (20.6)	1.220 (31.0)	16
15	M22 x 1 - 6H	.760 (19.3)	1.050 (26.7)	.880 (22.4)	1.290 (32.8)	20
17	M25 x 1 - 6H	.780 (19.8)	1.070 (27.2)	.940 (23.9)	1.350 (34.3)	24
19	M28 x 1 - 6H	.790 (20.1)	1.080 (27.4)	.970 (24.6)	1.380 (35.1)	28
21	M31 x 1 - 6H	.820 (20.8)	1.110 (28.2)	1.060 (26.9)	1.470 (37.3)	32
23	M34 x 1 - 6H	.860 (21.8)	1.150 (29.2)	1.130 (28.7)	1.540 (39.1)	32
25	M37 x 1 - 6H	.890 (22.6)	1.180 (30.0)	1.190 (30.2)	1.730 (43.9)	40

APPLICATION NOTES

- Material/ Finish:
Adapter, Elbow- High Grade Engineering Thermoplastic/ See Table III.
Coupling and Compression Nuts- High Grade Engineering Thermoplastic/ N.A.
O- Ring- Fluorosilicone or Silicone/ N.A.
Anti- Rotation device: Corrosion resistant material.
- Metric Dimensions are in parentheses and are for reference only.

189-039 Composite Connector Backshell Adapter for MIL-PRF-28876 Fiber Optic Connectors Straight, 45° and 90°

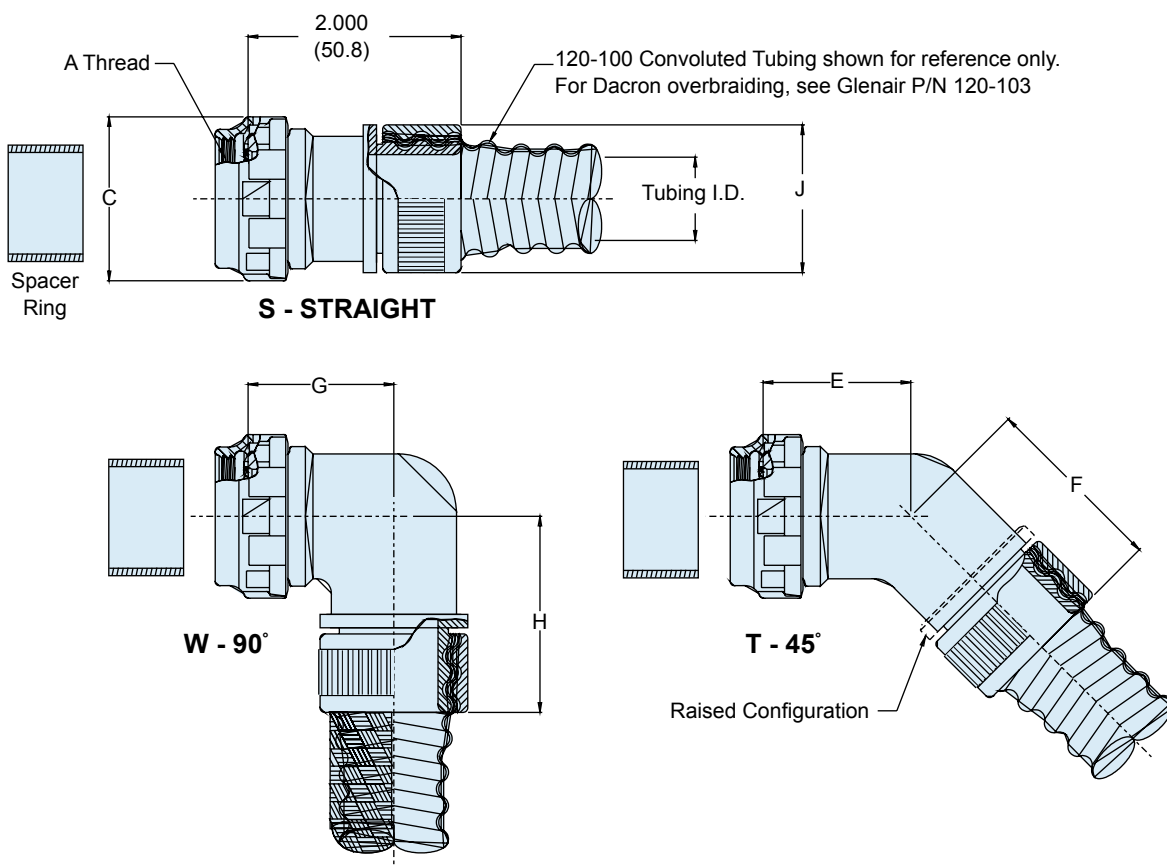
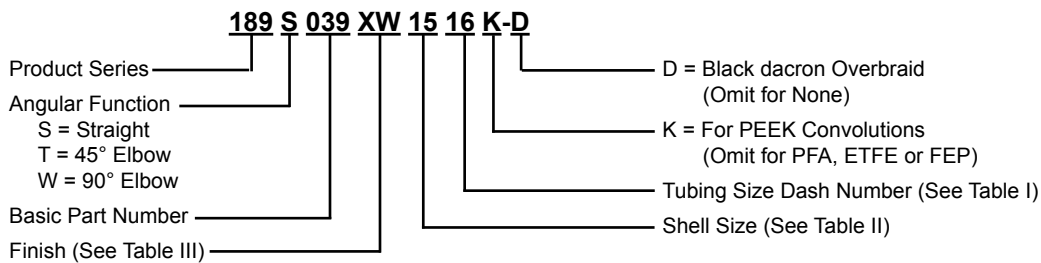

APPLICATION NOTES

- | | |
|--|--|
| <p>1. Metric dimensions (mm) are in parentheses and are for reference only.</p> <p>2. Material:
 Adapter, Coupling and Compression Nuts - High-Grade Engineering Thermoplastic.
 O-Ring - Fluorosilicone or Silicone.
 Anti-Rotation Device: Corrosion Resistant Material.</p> | <p>3. Unless otherwise specified, the backshell body to be supplied finished per Table III. All other components to be supplied without plating.</p> <p>4. CAUTION: Style T 45° and Style W 90° low profile elbows may cause signal loss due to abrupt bend radius. Suggest using 189-010, 1.0 R Style elbows where possible.</p> <p>5. Spacer Ring packaged loose with backshell. Install ring against connector insert prior to coupling backshell.</p> |
|--|--|

189-039
Composite Connector Backshell Adapter for
MIL-PRF-28876 Fiber Optic Connectors
Straight, 45° and 90°



TABLE I: TUBING SIZE

Dash No.	Conduit I.D.	J Dia Max
06	.188 (4.8)	.790 (20.1)
09	.281 (7.1)	.985 (25.0)
10	.312 (7.9)	.985 (25.0)
12	.375 (9.5)	1.035 (26.3)
14	.437 (11.1)	1.100 (27.9)
16	.500 (12.7)	1.160 (29.5)
20	.625 (15.9)	1.285 (32.6)
24	.750 (19.1)	1.480 (37.6)
28	.875 (22.2)	1.670 (42.4)
32	1.000 (25.4)	1.720 (43.7)
40	1.250 (31.8)	2.100 (53.3)
48	1.500 (38.1)	2.420 (61.5)

TABLE II: SHELL SIZE

Shell Size	A Thread Class 2B	E ±.060 (1.5)	F ±.090 (2.3)	G ±.060 (1.5)	H ±.090 (2.3)	Tubing Size Max
11	3/4-20 UNEF	.750 (19.1)	1.020 (25.9)	.810 (20.6)	1.220 (31.0)	16
13	7/8-20 UNEF	.760 (19.3)	1.050 (26.7)	.880 (22.4)	1.290 (32.8)	20
15	1-20 UNEF	.780 (19.8)	1.070 (27.2)	.940 (23.9)	1.350 (34.3)	24
23	1 7/16-18 UNEF	.890 (22.6)	1.180 (30.0)	1.190 (30.2)	1.730 (43.9)	40

TABLE III: FINISH

SYM	MATERIAL	FINISH
XM	Composite	Electroless Nickel
XW	Composite	Cadmium O.D. Over Electroless Nickel
XO	Composite	No Plating—Base

712-416 • PEEK Only

Composite Straight Backshell Adapter for MIL-DTL-38999 Series III and IV Fiber Optic Connectors

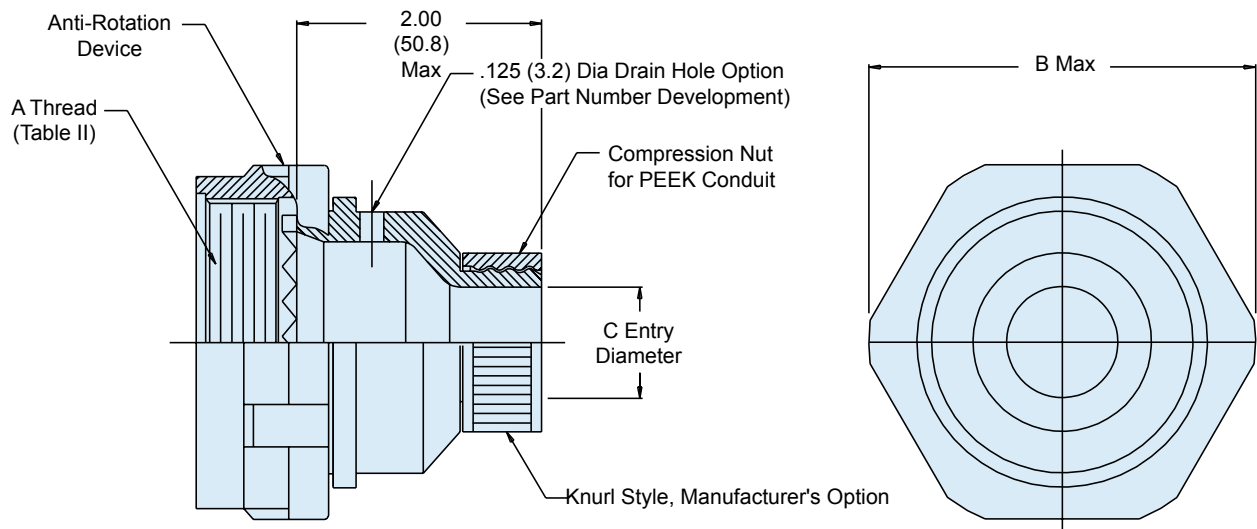
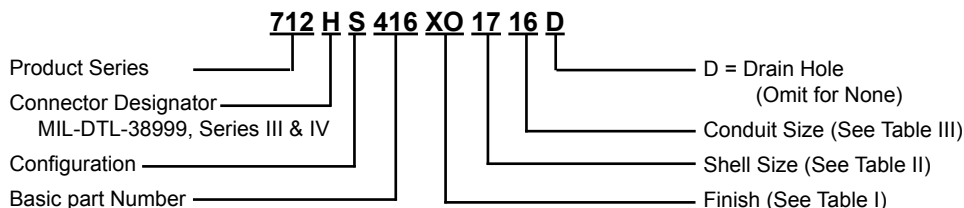

TABLE I: FINISH		
SYM	MATERIAL	FINISH
XM	Composite	Electroless Nickel
XW	Composite	Cadmium O.D. Over Electroless Nickel
XO	Composite	No Plating—Base

TABLE II: SHELL SIZE		
Shell Size	A Thread ISO Metric	B Max
11	M15 x 1 - 6H	.980 (24.0)
13	M18 x 1 - 6H	1.160 (28.4)
15	M22 x 1 - 6H	1.280 (32.5)
17	M25 x 1 - 6H	1.410 (35.8)
19	M28 x 1 - 6H	1.520 (38.6)
21	M31 x 1 - 6H	1.640 (41.7)
23	M34 x 1 - 6H	1.770 (43.4)
25	M37 x 1 - 6H	1.890 (48.0)

TABLE III: PEEK TUBING SIZE		
Dash No.	Fractional Size	C Entry Dia
06	3/16	.100 (2.5)
09	9/32	.171 (4.2)
12	3/8	.265 (6.7)
16	1/2	.390 (9.6)
20	5/8	.515 (12.6)
24	3/4	.640 (15.7)
28	7/8	.765 (18.7)
32	1	.890 (21.8)

- ### APPLICATION NOTES
- Metric dimensions (mm) are in parentheses and are for reference only.
 - Material:
 Adapter, Coupling and Compression Nuts - High-Grade Engineering Thermoplastic.
 O-Ring - Fluorosilicone or Silicone.
 Anti-Rotation Device: Corrosion Resistant Material.
 - Unless otherwise specified, the backshell body to be supplied finished per Table I. All other components to be supplied without plating.

Custom Conduit Assemblies

Wired, Terminated and Tested—Ready for Use

Glenair Custom Fiber Optic Conduit Assemblies

Glenair's complete capability in interconnect systems extends to the design, manufacture and test of custom conduit assemblies - built to your exact specifications. Our turn-key service includes everything from engineering and design assistance to the on-time delivery of completely wired, terminated and tested assemblies—ready for immediate use.

Glenair's has established an enviable reputation for consistently high quality. Regardless of simplicity or complexity, or whether quantities are large or small, the same high standards of quality assurance are applied uniformly. Our zero-defect quality

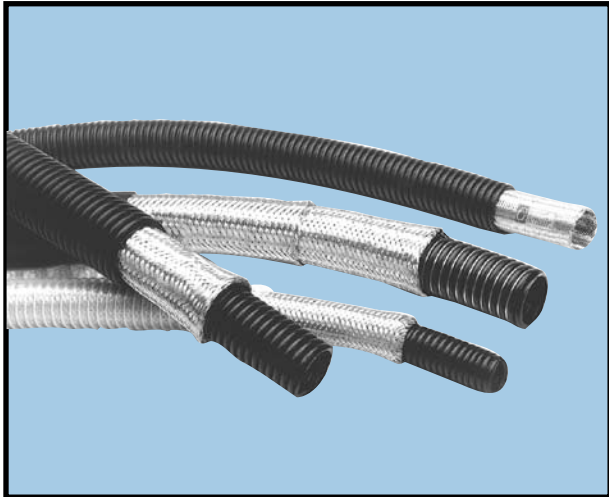

systems and strict adherence to military and commercial testing standards ensures each conduit assembly is thoroughly inspected at each stage of the assembly process. Each system undergoes a final inspection process which includes appearance, identification, dielectric, continuity, and insulation tests



conducted on a 100% basis in preparation for final customer source inspection.

Glenair has built electrical, optical and hybrid assemblies for military, commercial and industrial customers since the 1950's. Our expertise extends from simple point to point assemblies to complex multi-branch and fiber optic systems. Today, we're building everything from overmolded fiber optic assemblies for marine use, to wheel-well assemblies for the world's leading aircraft manufacturers.

Our in-house braiding and sleeving capabilities enable us to build both repairable and non-repairable assemblies suitable for use in harsh electromagnetic and environmental conditions. We offer a complete range of jacketing, shielding and braided protective covering options including NBC (nuclear, biological, chemical) materials.

From unique, one-of-a-kind conduit system, to high volume mass production needs, Glenair can provide you with consistent quality, reliable service and cost-effective wire media protection solutions.

189 M* 052 Convolute Tubing Backshell for Series 80 "Mighty Mouse" Fiber Optic Connectors

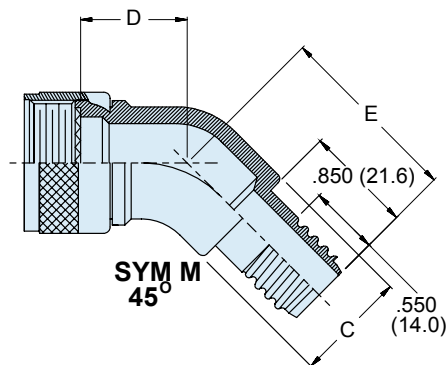
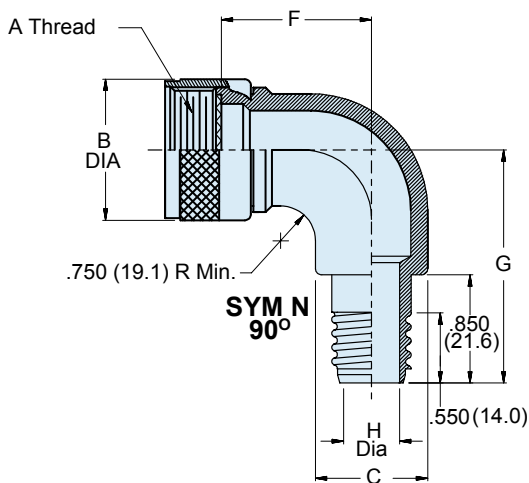
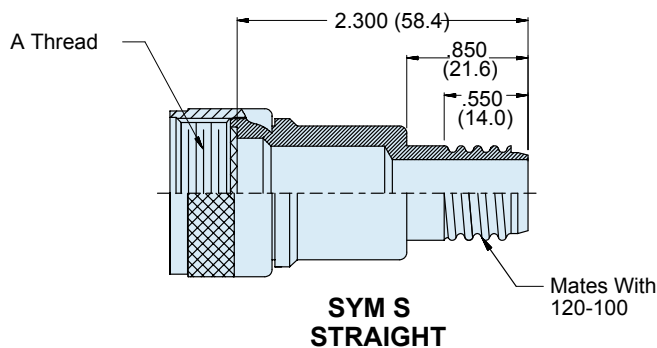
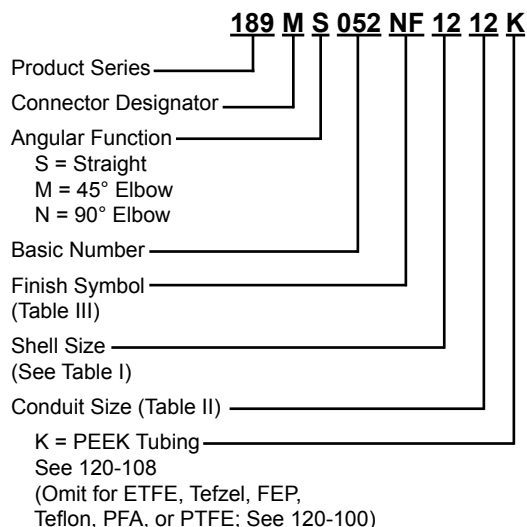

APPLICATION NOTES

1. Material/ Finish:
Adapter, Coupling Nut and Ferrule- Al Alloy/ See Table II.
O-Ring: Fluorosilicone/ N.A.
Detent Spring: Torton/ N.A.
2. Assembly to be identified with manufacturer's name and P/N, space permitting.
3. Metric dimensions (mm) are indicated in parentheses.

189 M* 052
Convolute Tubing Backshell
for Series 80 "Mighty Mouse" Fiber Optic Connectors



TABLE I: SHELL SIZE

Shell Size	A Thread Class 2B	B Max	C	D Max	E Max	F Max	G Max
12	.6875-24 UNEF-2A	.910 (23.1)	.620 (15.7)	.910 (23.1)	1.250 (31.8)	1.985 (50.4)	2.395 (60.8)
14	.9375-20 UNEF-2A	1.250 (31.8)	.875 (22.2)	1.020 (25.9)	1.370 (34.8)	2.115 (53.7)	2.465 (62.6)
15	.9375-20 UNEF-2A	1.250 (31.8)	.875 (22.2)	1.020 (25.9)	1.370 (34.8)	2.115 (53.7)	2.465 (62.6)

TABLE II: PEEK CONDUIT SIZE

Conduit Size		H Max
Frac. Size	Dash No.	
3/8	12	.320 (8.1)
1/2	16	.425 (10.8)
5/8	20	.550 (14.0)
3/4	24	.680 (17.3)

TABLE III: FINISH

SYM	MATERIAL	FINISH
NF	Aluminum	Cadmium/Olive Drab over Electroless Nickel (500 Hr. Salt Spray)
B	Aluminum	Cadmium Plate/Olive Drab
J	Aluminum	Gold Iridite over Cadmium Plate over Nickel
N	Aluminum	Cadmium Plate/Olive Drab over Nickel
M	Aluminum	Electroless Nickel
T	Aluminum	Cadmium Plate/Bright Dip over Nickel

Q: What's the Difference Between a Fly-by-Wire Flight Control System and a Fly-by-Light Version?

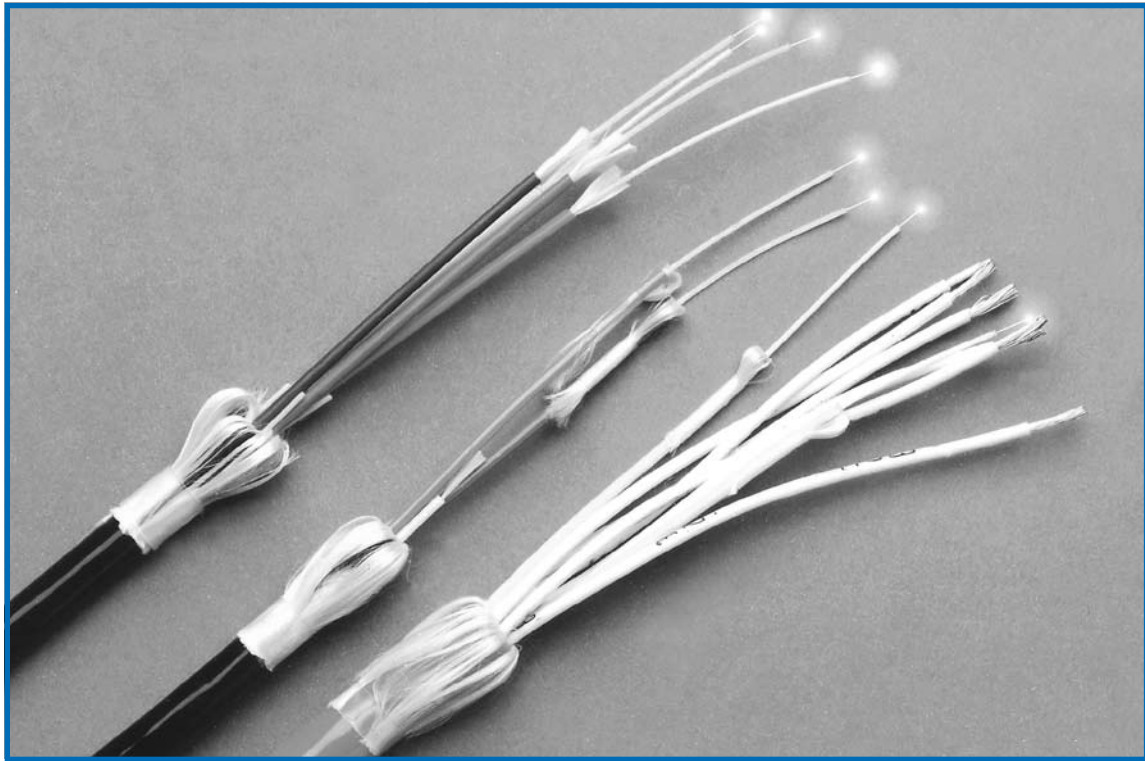

A: About 20 Lbs. Per Cable.

What a difference a choice in media can make! Compared to copper, optical fiber is smaller in size and lighter in weight. In flight control applications, the ratio of weight reduction can be as great as 15:1 when copper conductors are replaced by silica optical fiber. In general aircraft applications, weight savings

translate directly to fuel fraction reductions. In military applications, weight savings can extend the range of every mission. Glenair fiber optic connectors and our unique packaging technologies, are built from the toughest and lightest materials available: from silica fiber to composite thermoplastic connector bodies and



1211 Air Way

Glendale, California 91201-2497

Telephone: 818-247-6000 · Facsimile: 818-500-9912 · EMail: sales@glenair.com

United States · United Kingdom · Germany · Nordic · France · Italy · Spain · Japan

www.glenair.com

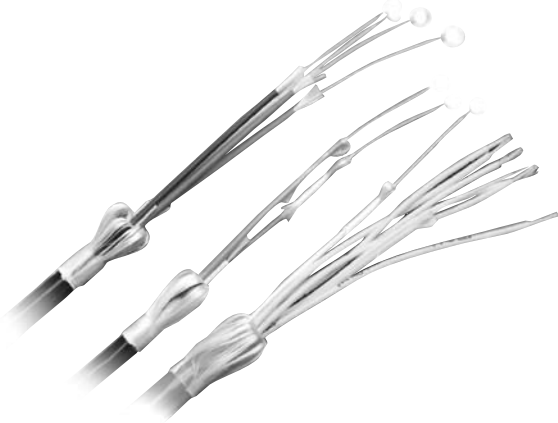

PRODUCT FEATURES

- Kevlar® Reinforced Strength Filaments
- Hytrel® Outer Jacket Standard
- Simplex, Duplex and Hybrid Constructions
- Graded Index and Singlemode Stepped Index Designs
- -40° C to +85° C Temperature Range
- No Minimums—Short Runs a Specialty
- Fast Turnaround

Glenair Fiber Optic Extruded Cable is Ideal for Prototypes and Other Short-Run Applications

Fiber Optic Cable Construction

There are typically five elements that make up the construction of a fiber optic cable: the optic core, optic cladding, buffer, strength member and outer jacket. The optic core is the light-carrying element at the center of the optical fiber. It is commonly made from a combination of highly purified silica and germania. Surrounding the core is the optic cladding made of pure silica. The combination of these materials makes the principle of total internal reflection possible, as the difference in materials used in the core and the cladding creates an extremely reflective surface at the point in which they interface. Light pulses entering the fiber core reflect off the core/cladding interface and thus remain within the core as they move down the line.

Surrounding the cladding is a buffer material which acts as a shock absorber to protect the core and cladding from damage. A strength member, typically Aramid, surrounds the buffer adding critical tensile strength to the cable to prevent damage from pull forces during installation. The outer jacket protects against abrasion and environmental damage. The type of jacket used also defines the cable's duty and flammability rating.

Glenair's In-House Capabilities

Glenair's in-house fiber optic cable extrusion line provides the capability to extrude a variety of short-run specialty cables from simplex to hybrid constructions. Options include a selection of strength filaments such as Aramid yarn and extruded outer jacket materials. Our in-house extrusion line is geared to short-run, prototype projects and other applications which do not meet the large cable manufacturer's minimum length requirements. For fast response on custom cables, please provide the factory with your exact needs (fiber type and size, cable type/construction, optical performance and so on).

ABC 3571 Bulk Simplex Fiber Optic Cable 100/140 Graded Index

ABC3571

Basic Part
Number

CABLE SPECIFICATIONS	
Core/Mode Field Diameter	100 μm ± 4 μm
Cladding Diameter	140 μm ± 3 μm
Primary Buffer	500 μm ± 25 μm
Secondary Buffer	900 μm ± 50 μm
Jacket	.083 ± .007 Inch Diameter
Attenuation:	
@ 850 nm	6.0 dB/km
@ 1300 nm	4.0 dB/km
Bandwidth:	
@ 850 nm	100 Mhz/km Minimum
@ 1300 nm	100 Mhz/km Minimum
Numerical Aperture	.290 ± .015
Index Profile	Graded
Proof Test	≥100 KPSI
Operating Temperature	-40° C to 85° C

Consult Factory for price in feet or meters and for
Standard Length Tolerance

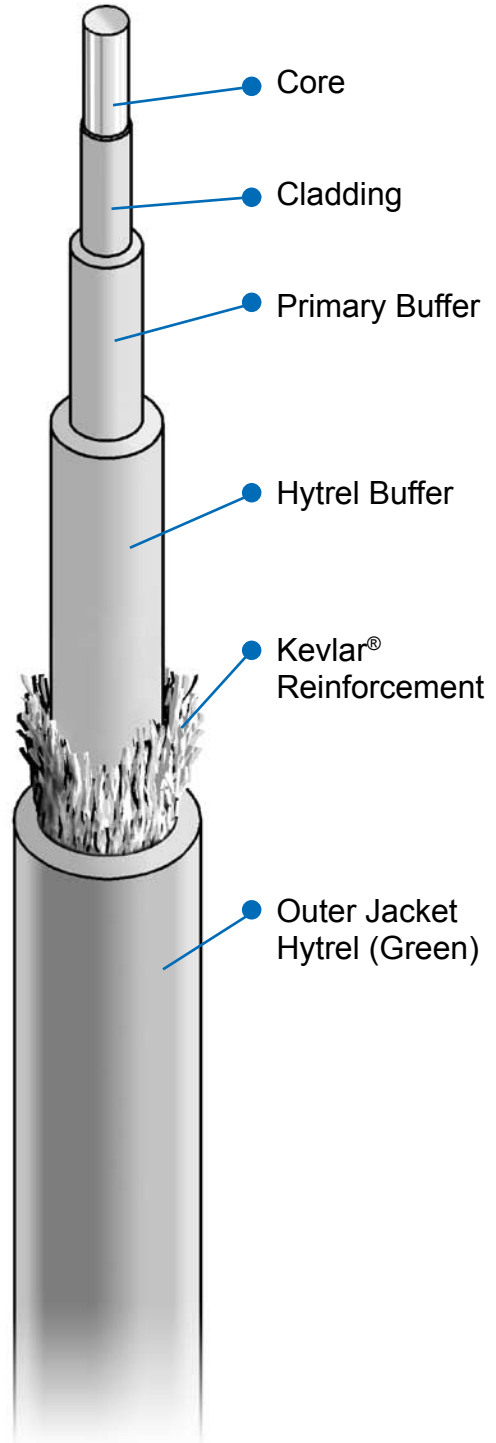

Kevlar® is a registered trademark of DuPont Company.

ABC 3580
Bulk Simplex Fiber Optic Cable
50/125 Graded Index



ABC3580
 Basic Part Number

CABLE SPECIFICATIONS	
Core/Mode Field Diameter	50 $\mu\text{m} \pm 3 \mu\text{m}$
Cladding Diameter	125 $\mu\text{m} \pm 3 \mu\text{m}$
Primary Buffer	500 $\mu\text{m} \pm 25 \mu\text{m}$
Secondary Buffer	900 $\mu\text{m} \pm 50 \mu\text{m}$
Jacket	.079 \pm .007 Inch Diameter
Attenuation: @ 850 nm @ 1300 nm	4.0 dB/km 2.5 dB/km
Bandwidth: @ 850 nm @ 1300 nm	400 Mhz/km Minimum 400 Mhz/km Minimum
Numerical Aperture	.200 Nominal
Index Profile	Graded
Proof Test	100 KPSI
Operating Temperature	-40° C to 85° C

Consult Factory for price in feet or meters and for Standard Length Tolerance

Glenair also carries 62.5 and 50 μm Multimode fiber that meet FAR25 flammability requirements. Consult factory for more information.

Kevlar® is a registered trademark of DuPont Company.

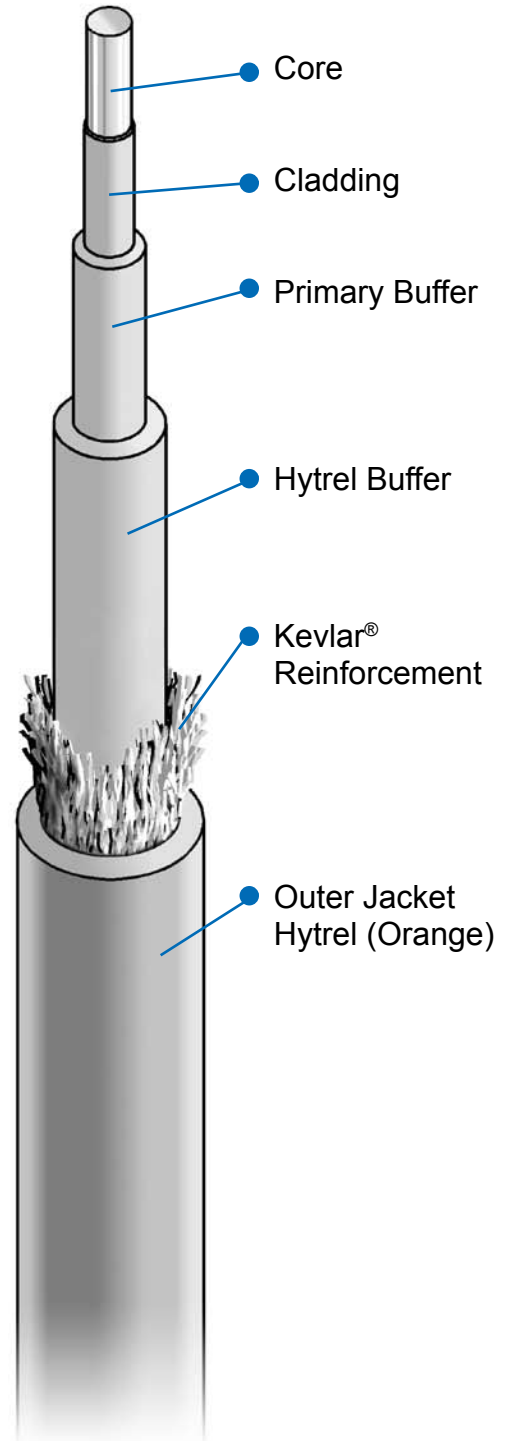

ABC 3586

Bulk Simplex Fiber Optic Cable

9.3/125 Singlemode Stepped Index

ABC3586

Basic Part
Number

CABLE SPECIFICATIONS	
Core/Mode Field Diameter	9.3 $\mu\text{m} \pm 3 \mu\text{m}$
Cladding Diameter	125 $\mu\text{m} \pm 2 \mu\text{m}$
Primary Buffer	500 $\mu\text{m} \pm 25 \mu\text{m}$
Secondary Buffer	900 $\mu\text{m} \pm 50 \mu\text{m}$
Jacket	.083 \pm .007 Inch Diameter
Attenuation:	
@ 850 nm	3.0 dB/km
@ 1300 nm	2.0 dB/km
Numerical Aperture	.110 \pm .020
Index Profile	Stepped
Proof Test	≥ 100 KPSI
Operating Temperature	-40° C to 85° C

**Consult Factory for price in feet or meters and for
Standard Length Tolerance**

Glenair also carries 62.5 and 50 μm Multimode fiber that meet FAR25 flammability requirements. Consult factory for more information.

Kevlar® is a registered trademark of DuPont Company.

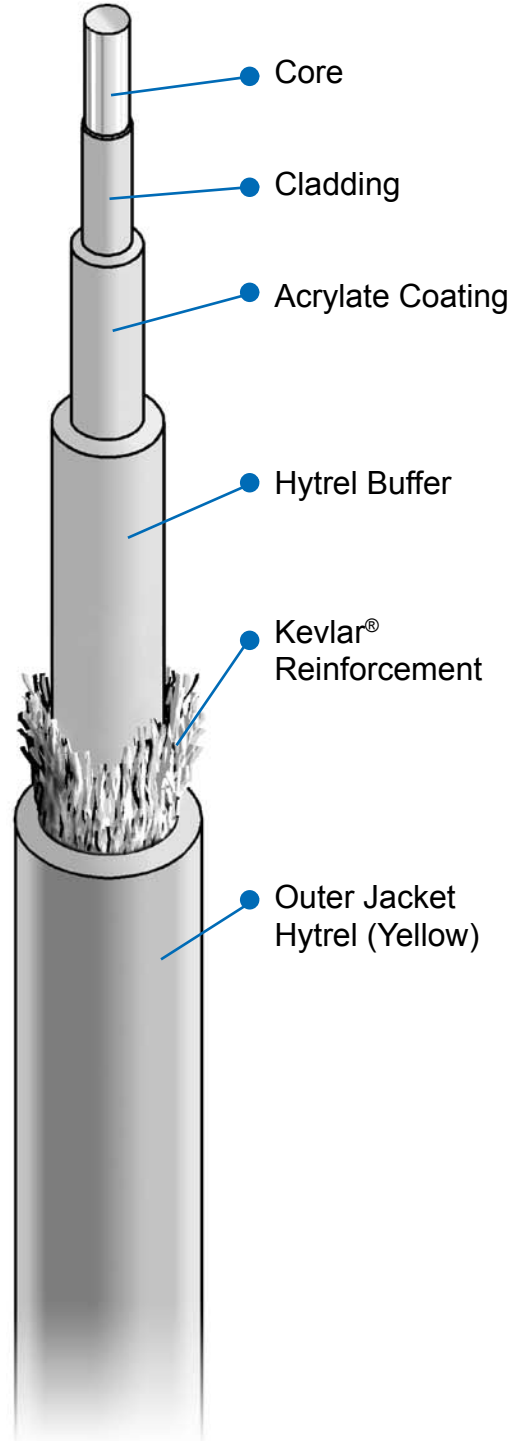

ABC 3569
Bulk Simplex Fiber Optic Cable
62.5/125 Graded Index



ABC3569
 Basic Part
 Number

CABLE SPECIFICATIONS	
Core/Mode Field Diameter	62.5 $\mu\text{m} \pm 3 \mu\text{m}$
Cladding Diameter	125 $\mu\text{m} \pm 3 \mu\text{m}$
Primary Buffer	500 $\mu\text{m} \pm 25 \mu\text{m}$
Secondary Buffer	900 $\mu\text{m} \pm 50 \mu\text{m}$
Jacket	.083 \pm .007 Inch Diameter
Attenuation:	
@ 850 nm	6.0 dB/km
@ 1300 nm	4.0 dB/km
Bandwidth:	
@ 850 nm	160 Mhz/km Minimum
@ 1300 nm	500 Mhz/km Minimum
Numerical Aperture	0.275 Nominal
Index Profile	Graded
Proof Test	≥ 100 KPSI
Operating Temperature	-40° C to 85° C

**Consult Factory for price in feet or meters and for
 Standard Length Tolerance**

Glenair also carries 62.5 and 50 μm Multimode fiber that meet FAR25 flammability requirements. Consult factory for more information.

Kevlar® is a registered trademark of DuPont Company.

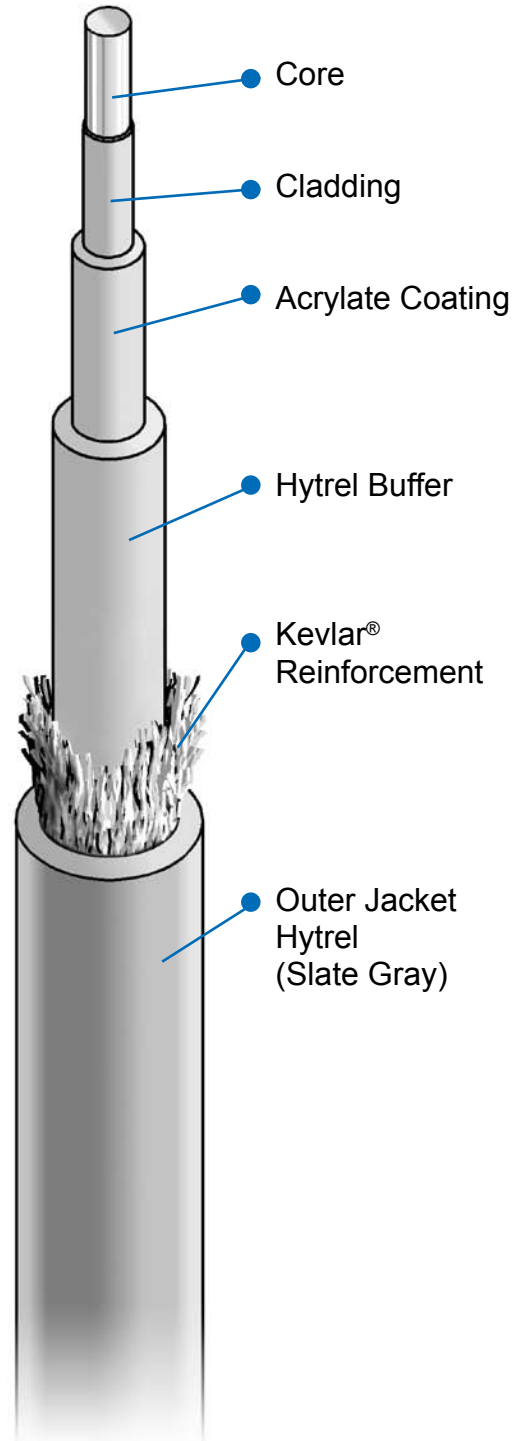

ABC 3821

Bulk Simplex Fiber Optic Cable

62.5/125 Graded Index Simplex Cable

ABC3821

Basic Part Number

CABLE SPECIFICATIONS	
Core/Mode Field Diameter	62.5 $\mu\text{m} \pm 3 \mu\text{m}$
Cladding Diameter	125 $\mu\text{m} \pm 3 \mu\text{m}$
Primary Buffer	500 $\mu\text{m} \pm 25 \mu\text{m}$
Secondary Buffer	900 $\mu\text{m} \pm 50 \mu\text{m}$
Jacket	.083 \pm .007 Inch Diameter
Attenuation:	
@ 850 nm	4.0 dB/km
@ 1300 nm	2.0 dB/km
Bandwidth:	
@ 850 nm	160 Mhz/km Minimum
@ 1300 nm	500 Mhz/km Minimum
Numerical Aperture	0.275 Nominal
Index Profile	Graded
Proof Test	≥ 100 KPSI
Operating Temperature	-40° C to 85° C
Core Noncircularity	$\leq 5\%$
Cladding Noncircularity	$\leq 2\%$

Consult Factory for price in feet or meters and for Standard Length Tolerance

Glenair also carries 62.5 and 50 μm Multimode fiber that meet FAR25 flammability requirements. Consult factory for more information.

Kevlar® is a registered trademark of DuPont Company.

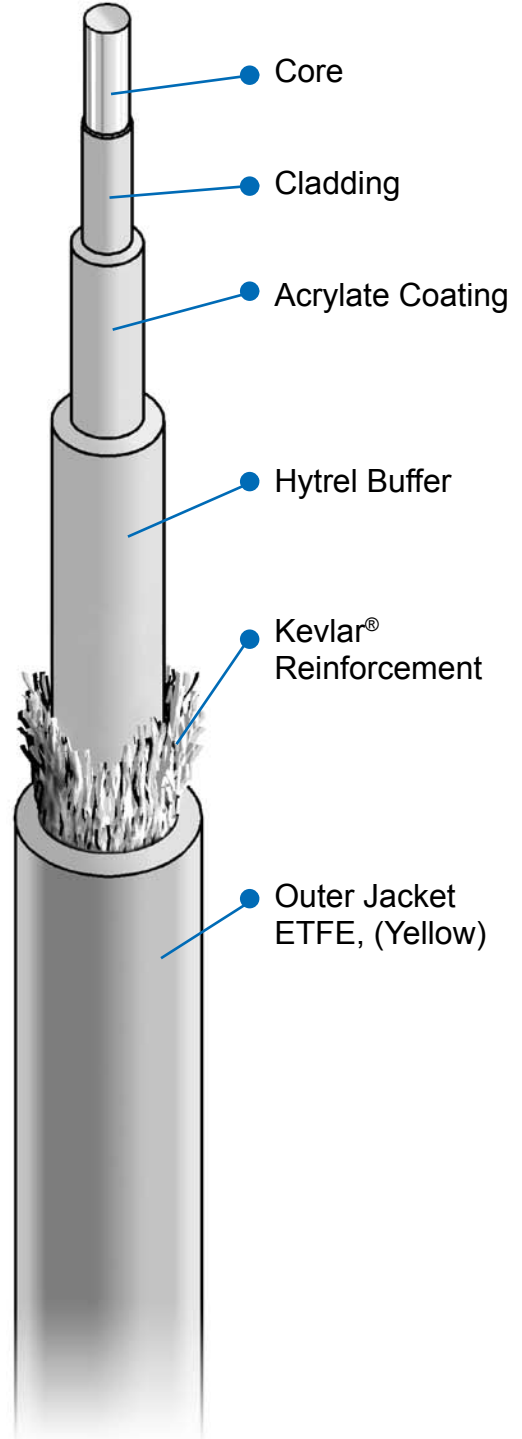

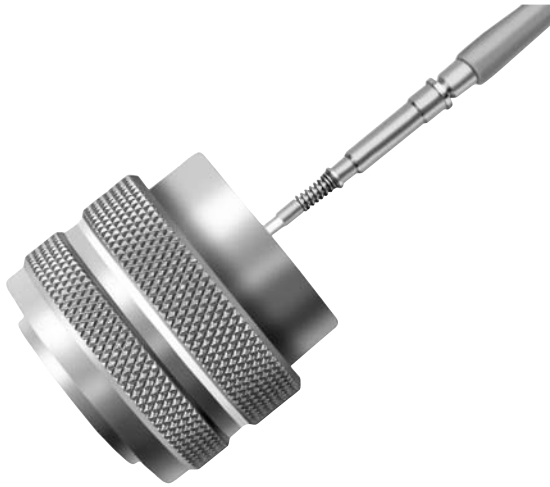

PRODUCT FEATURES

- Designed to Mate with MIL-DTL-38999 Series I and III Connectors
- Replaces the Need for Expensive Test Harnesses
- Easy to Inspect and Clean
- Same Terminus Mating Force as the MIL-DTL-38999 Connector for Repeatable Low-Loss Measurements
- Utilizes Precision Ceramic Ferrules
- Fast and Efficient Testing of Fiber Media in Factory or Field

Glenair Fiber Optic Test Probes and Connector Adapters Provide Accurate and Repeatable Testing of MIL-DTL-38999 Cable Assemblies

Patented optical test and measurement system

Traditional optical test harnesses are expensive and easily contaminated in normal use. Glenair's test probe, in conjunction with our precise-mating test adapter, offers a complete solution to optical test and measurement. The probe design offers precision alignment with the use of ceramic ferrules and alignment sleeves. The spring design offers the same termination pressure as the MIL-PRF-29504 terminus. The built-in insertion and removal tool on the test probe allows for quick probing from one channel to the next with repeatable performance. The probe also houses a rubber strain-relief boot to protect the optical fiber from potential bend stress.

Specified by advanced military aircraft programs

The Glenair fiber optic test probe system has become a standard tool for the field testing of fiber optic media in front-line fighter jets and other advanced aircraft. With the upgrading of so many avionic systems to fiber optics, the need for fast and efficient troubleshooting equipment has become paramount. The traditionally heavy and expensive test harnesses of the past are now being replaced with Glenair's lightweight and easy-to-use fiber optic test probes and adapters.

Troubleshooting a shell size 25 MIL-DTL-38999 Series III Connector previously required an expensive test harness with 29 fiber optic terminations. Today, this test assembly has been replaced by Glenair with a single disposable probe jumper and a re-usable connector adapter. The system is now being used in advanced military aircraft programs as well as in naval weapons systems, sonar, video, audio, and a wide range of other military and commercial applications. For more information on Glenair's patented Fiber Optic Test Probe and Connector Adapter System please contact the factory, or visit us at www.glenair.com.

U.S. PATENT 5960137

Step 1

The first step in using the optical test probes is to install each end of the probe cable assembly to the optical power meter and light source. Next, insert each probe into the calibration adapter.

The test probe loss can now be recorded as a reference measurement or may be "zeroed-out."

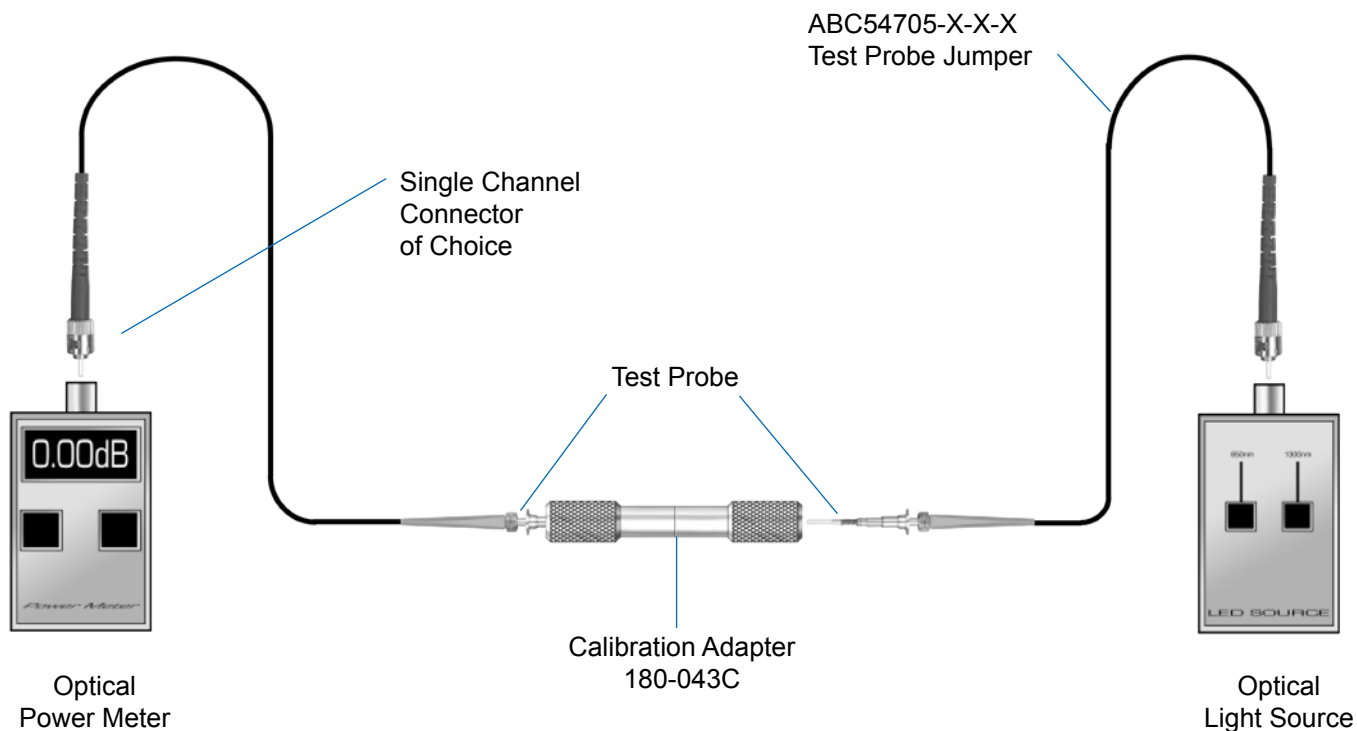

Refer to Tooling Section I for Test Probe Kit

Step 2

Now you are ready to perform optical measurements on the fiber optic cable harness. First, select the proper Glenair D38999 Series III Probe Adapter.

Now, mate or couple the adapters to each end of the cable harness. Next, insert each probe in the appropriate channel to be tested by pushing on the knurled area on the test probes. Read and record the optical performance.

To measure the next channel, remove the test probe by pushing on the large diameter of the test probe. The probe can now be removed and inserted into the next channel. Re-establishing or verification of reference can be performed at any time by following Step 1.

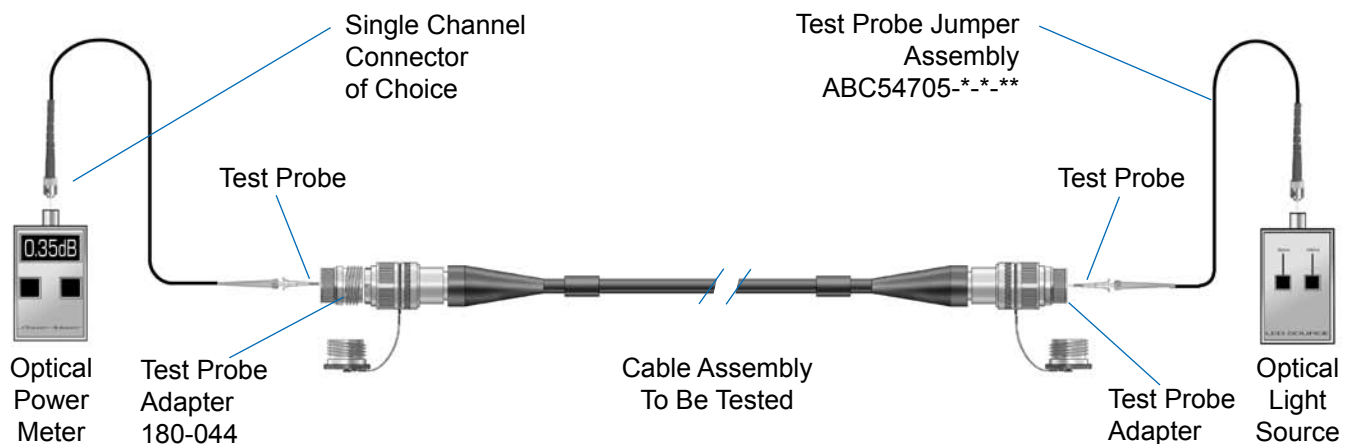

Refer to Tooling Section I for Test Probe Kit

ABC 54705 Fiber Optic Test Probe Simplex Cable Assembly

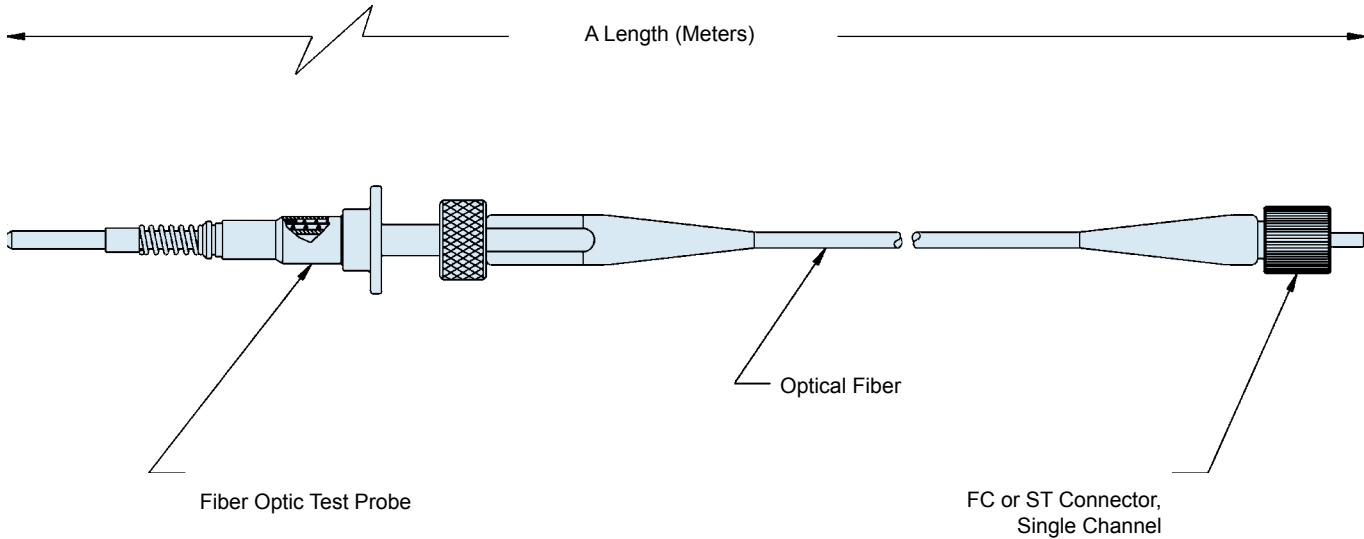
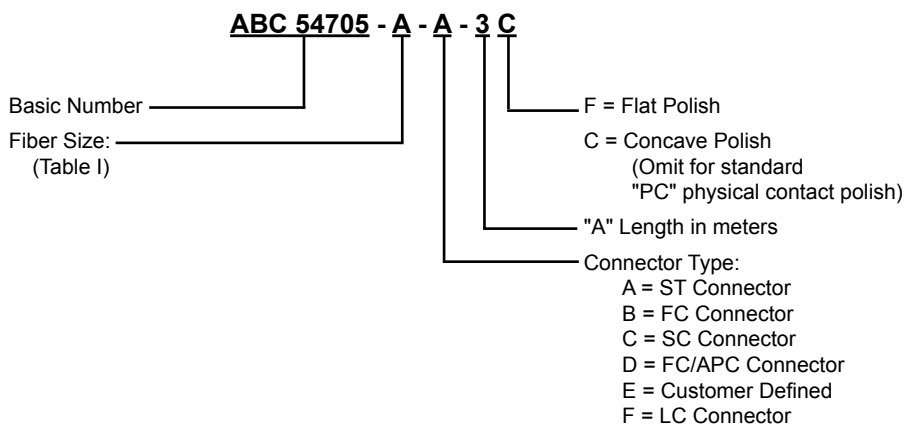
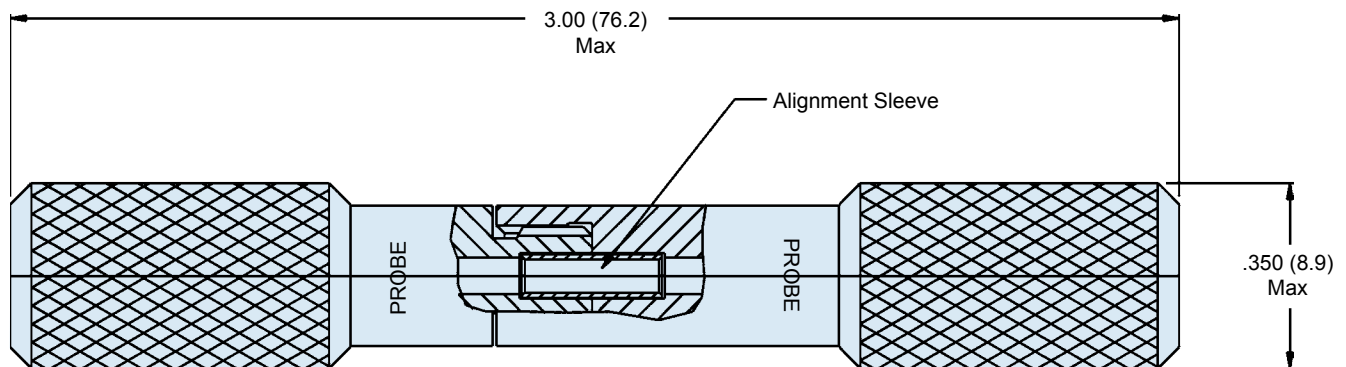
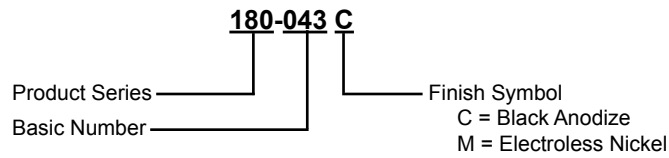

TABLE I: FIBER SIZE	
Symbol	Size
A	100/140 μm
B	62.5/125 μm
C	50/125 μm
D	200/230 μm
E	Singlemode 9.3/125
F	Customer Defined
G	SM 5.8/125 M/F DIA. .21na
H	SM 7.5/125 M/F DIA. .17na

Optical insertion loss ≤ 1.0 dB @ 850 or 1300 nm wavelength.
Glenair Fiber Optic Test Probe U.S. Patent Number 5,960,137.

180-043
Feedthrough Probe Connector for
MIL-DTL-38999 Series III Test Probe



U.S. PATENT 5960137

APPLICATION NOTES

1. Metric dimensions (mm) are in parentheses and are for reference only.
2. Assembly to be identified with "Probe" and "Probe."
3. Material/Finish:
Housing - Aluminum Alloy/See Part Number Development
Alignment Sleeve - Zirconia Ceramic/N.A.
Retaining Clips - Beryllium Copper/N.A.
4. Metric Dimensions (mm) are indicated in parentheses.

180-049
Feedthrough Probe Connector
to M29504/4 Pin Terminus

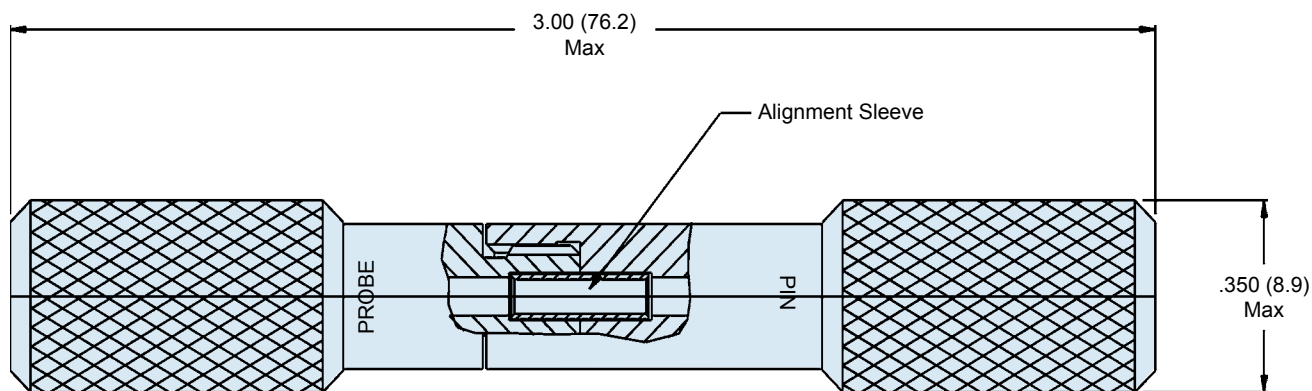
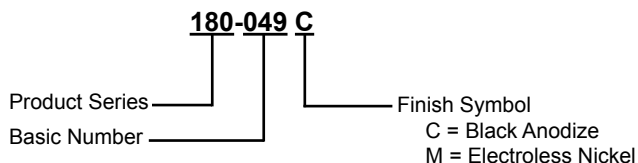

Accepts 181-002 and MIL-PRF-29504/ 4 Pin Terminus

U.S. PATENT 5,960,137

APPLICATION NOTES

1. Metric dimensions (mm) are in parentheses and are for reference only.
2. Assembly to be identified with "Probe" and "Pin."
3. Material/Finish:
Housing - Aluminum Alloy/See Part Number Development
Alignment Sleeve - Zirconia Ceramic/N.A.
Retaining Clips - Beryllium Copper/N.A.
4. Metric Dimensions (mm) are indicated in parentheses.

180-050
Feedthrough Probe Connector
Probe to Socket Terminus (M29504/5)



180-050 C

Product Series ———
 Basic Number ———
 Finish Symbol ———
 (See Table I)

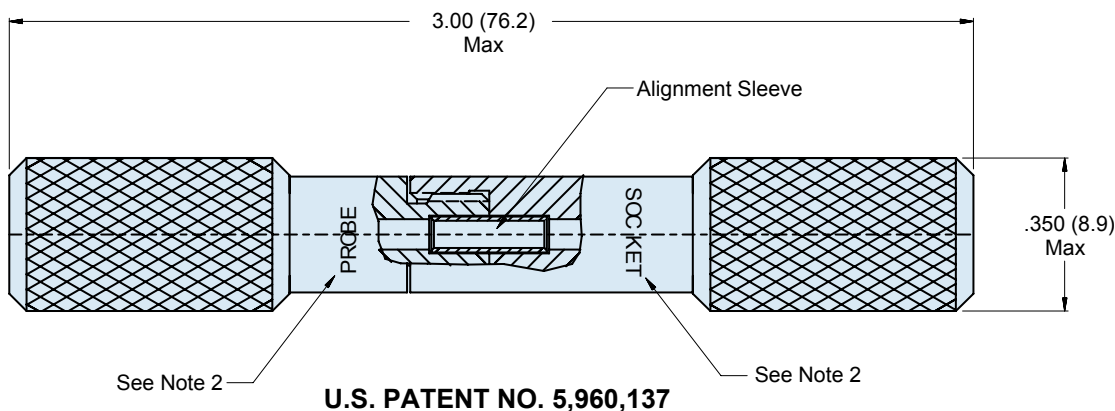
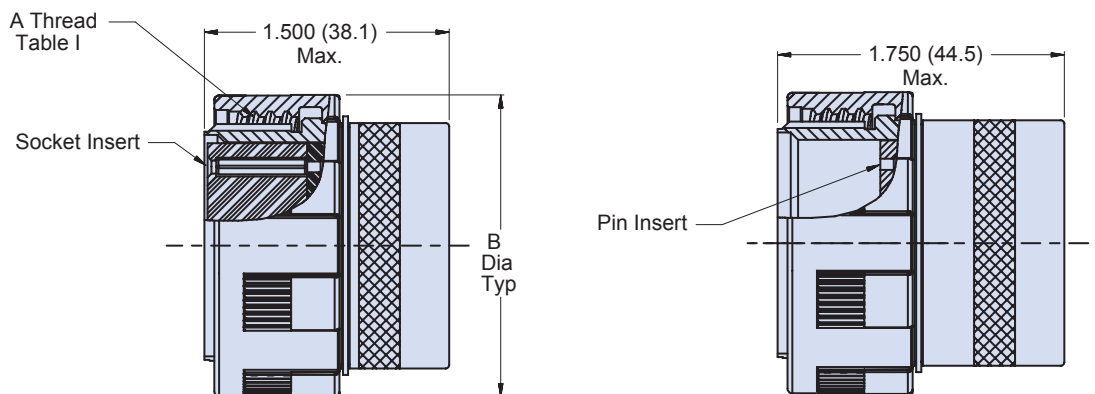
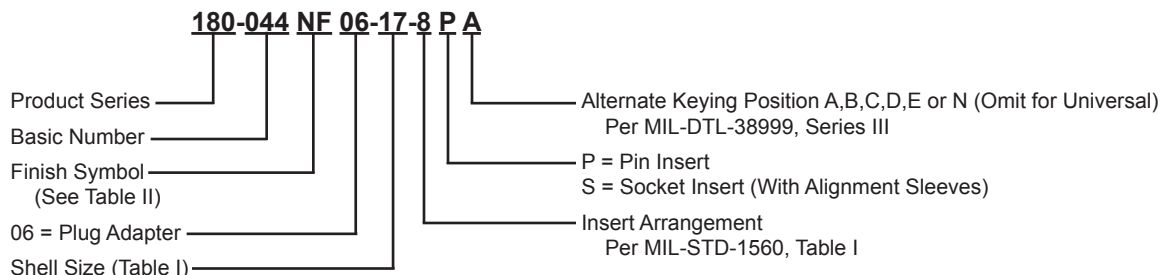

TABLE I: FINISH

SYM	MATERIAL	FINISH
C	Aluminum	Black Anodize
M	Aluminum	Electroless Nickel

APPLICATION NOTES

1. Assembly identified with manufacture's name and P/N as Space Permitted.
2. Assembly to be identified with "Probe" and "Socket."
3. Assembly to be identified with "Probe" and "Socket."
4. Material/ Finish:
 Housing: Al Alloy/ See Table I
 Alignment Sleeve: Zirconia Ceramic/ N.A.
 Retaining Clips: Beryllium Copper/ N.A.
5. Metric dimensions (mm) are indicated in parentheses.



**06
PLUG ASSEMBLY
U.S. PATENT NO. 5,960,137**

APPLICATION NOTES

1. Assembly identified with manufacturer's name and P/N, Space Permitting.
2. For Fiber Optic Test Probe Terminus See Glenair Drawing 181-006
3. Material/ Finish:
 - Barrel/ Shell- Al Alloy/ See Table II
 - Insert, Coupling Nut- Hi- Grade Engineering Thermoplastic/ N.A.
 - Alignment Sleeve- Zirconia Ceramic/ N.A.
 - Retaining Ring- Stainless Steel/ N.A.
 - Retaining Clips- Beryllium Copper/ N.A.
 - Lock Cap, Lock Nut- Al Alloy/ Black Anodize.
4. Metric dimensions (mm) are indicated in parentheses.

**180-044 (06 Plug)
Fiber Optic Test Adapter
MIL-DTL-38999 Series III**

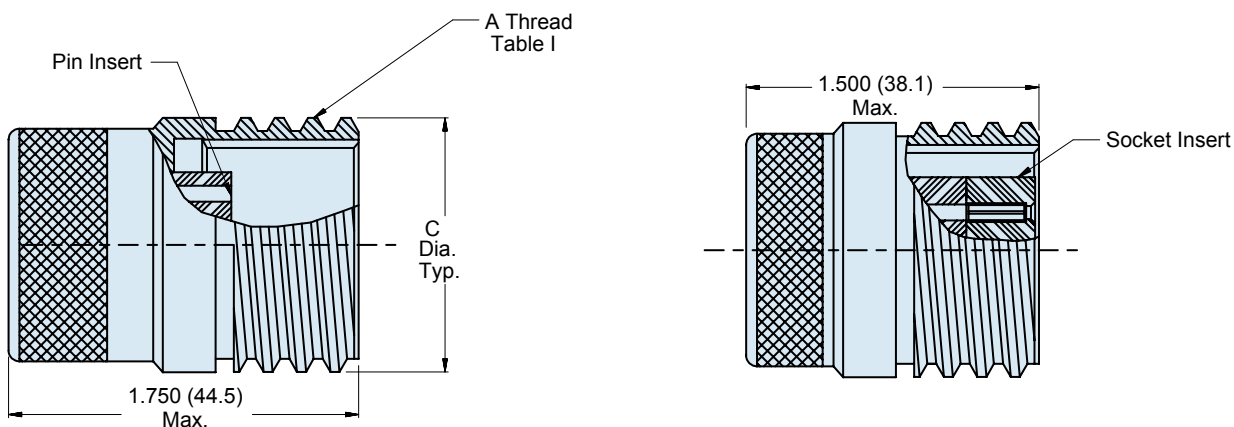
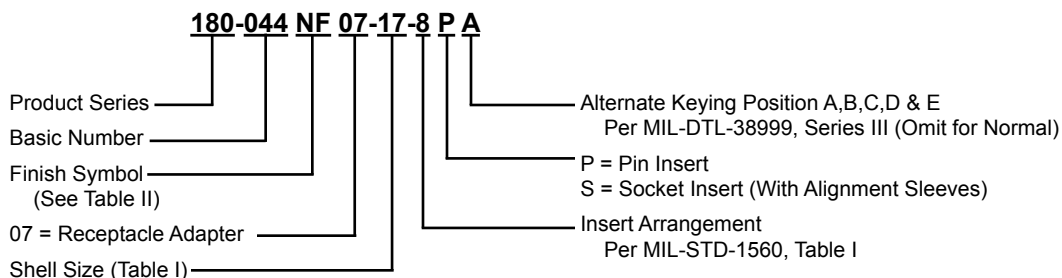

TABLE I: SHELL SIZE AND INSERT ARRANGEMENTS

Shell Size & Insert Arrangement Dash No.	Shell Size Code Ref.	A Thread 0.1P-0.3L-TS-2	B Dia Max	C Dia Max
11-2	B	.750 (19.1)	.964 (24.5)	.750 (19.1)
13-4	C	.875 (22.2)	1.141 (29.0)	.875 (22.2)
15-5	D	1.000 (25.4)	1.266 (32.2)	1.000 (25.4)
15-97	D	1.000 (25.4)	1.266 (32.2)	1.000 (25.4)
17-8	E	1.187 (30.1)	1.391 (35.3)	1.187 (30.1)
19-11	F	1.250 (31.8)	1.500 (38.8)	1.250 (31.8)
21-16	G	1.375 (34.9)	1.625 (41.3)	1.375 (34.9)
23-21	H	1.500 (38.1)	1.750 (44.5)	1.500 (38.1)
23-99	H	1.500 (38.1)	1.750 (44.5)	1.500 (38.1)
25-20	J	1.625 (41.3)	1.875 (47.6)	1.625 (41.3)
25-29	J	1.625 (41.3)	1.875 (47.6)	1.625 (41.3)

TABLE II: FINISH

SYM	MATERIAL	FINISH
B	Aluminum	Cadmium Plate/Olive Drab
M	Aluminum	Electroless Nickel
NF	Aluminum	Cadmium/Olive Drab over Electroless Nickel (500-Hr. Salt Spray)
J	Aluminum	Iridite, Gold over Cadmium Plate over Electroless Nickel



**07
RECEPTACLE ASSEMBLY
U.S. PATENT NO. 5,960,137**

APPLICATION NOTES

1. Assembly identified with manufacturer's name and P/N, Space Permitting.
2. For Fiber Optic Test Probe Terminus
See Glenair Drawing 181-006
3. Material/ Finish:
 - Barrel/ Shell- Al Alloy/ See Table II
 - Insert, Coupling Nut- Hi- Grade Engineering Thermoplastic/ N.A.
 - Alignment Sleeve- Zirconia Ceramic/ N.A.
 - Retaining Ring- Stainless Steel/ N.A.
 - Retaining Clips- Beryllium Copper/ N.A.
 - Lock Cap, Lock Nut- Al Alloy/ Black Anodize.
4. Metric dimensions (mm) are indicated in parentheses.

**180-044 (07 Receptacle)
Fiber Optic Test Adapter
MIL-DTL-38999 Series III**

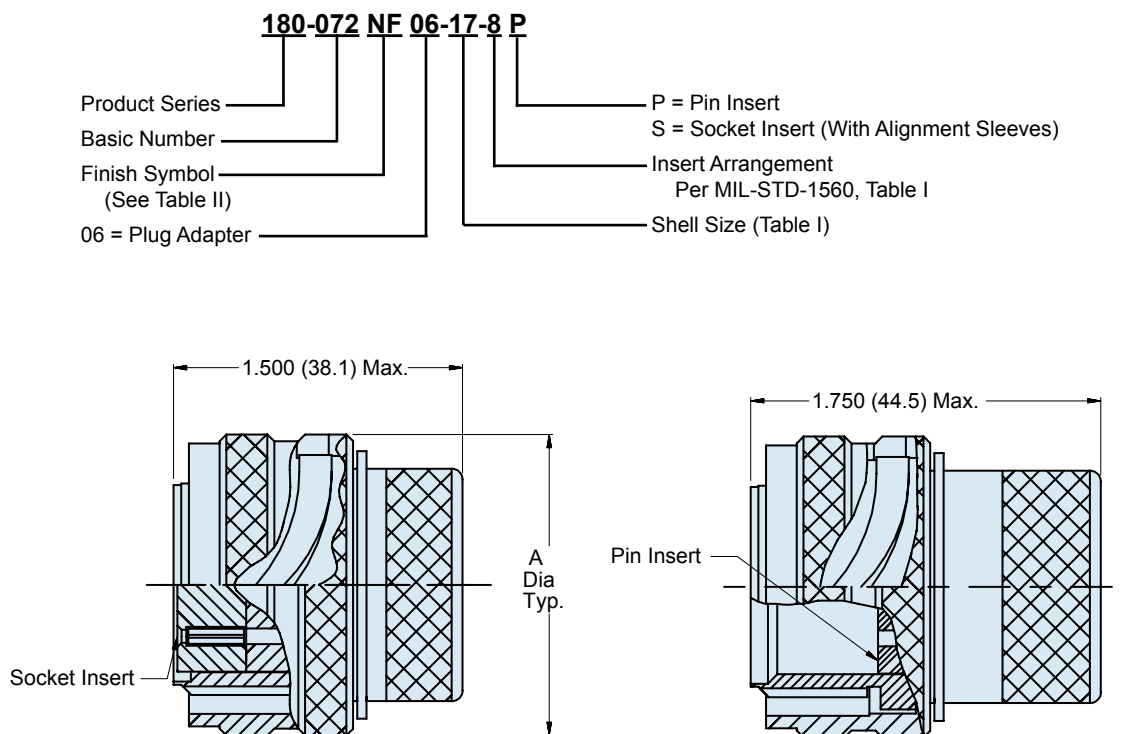

TABLE I: SHELL SIZE AND INSERT ARRANGEMENTS

Shell Size & Insert Arrangement Dash No.	Shell Size Code Ref.	A Thread 0.1P-0.3L-TS-2	B Dia Max	C Dia Max
11-2	B	.750 (19.1)	.964 (24.5)	.750 (19.1)
13-4	C	.875 (22.2)	1.141 (29.0)	.875 (22.2)
15-5	D	1.000 (25.4)	1.266 (32.2)	1.000 (25.4)
15-97	D	1.000 (25.4)	1.266 (32.2)	1.000 (25.4)
17-8	E	1.187 (30.1)	1.391 (35.3)	1.187 (30.1)
19-11	F	1.250 (31.8)	1.500 (38.8)	1.250 (31.8)
21-16	G	1.375 (34.9)	1.625 (41.3)	1.375 (34.9)
23-21	H	1.500 (38.1)	1.750 (44.5)	1.500 (38.1)
23-99	H	1.500 (38.1)	1.750 (44.5)	1.500 (38.1)
25-20	J	1.625 (41.3)	1.875 (47.6)	1.625 (41.3)
25-29	J	1.625 (41.3)	1.875 (47.6)	1.625 (41.3)

TABLE II: FINISH

SYM	MATERIAL	FINISH
B	Aluminum	Cadmium Plate/Olive Drab
M	Aluminum	Electroless Nickel
NF	Aluminum	Cadmium/Olive Drab over Electroless Nickel (500-Hr. Salt Spray)
J	Aluminum	Iridite, Gold over Cadmium Plate over Electroless Nickel



**06
PLUG ASSEMBLY
U.S. PATENT NO. 5,960,137**

APPLICATION NOTES

1. Assembly identified with manufacturer's name and P/N, Space Permitting.
2. For Fiber Optic Test Probe Terminus
See Glenair Drawing 181-006
3. Material/ Finish:
 - Barrel/ Shell- Al Alloy/ See Table II
 - Insert, Coupling Nut- Hi- Grade Engineering Thermoplastic/ N.A.
 - Alignment Sleeve- Zirconia Ceramic/ N.A.
 - Retaining Ring- Stainless Steel/ N.A.
 - Retaining Clips- Beryllium Copper/ N.A.
 - Lock Cap, Lock Nut- Al Alloy/ Black Anodize.
4. Metric dimensions (mm) are indicated in parentheses.

**180-072 (06 Plug)
Fiber Optic Test Adapter
MIL-DTL-38999 Series I**

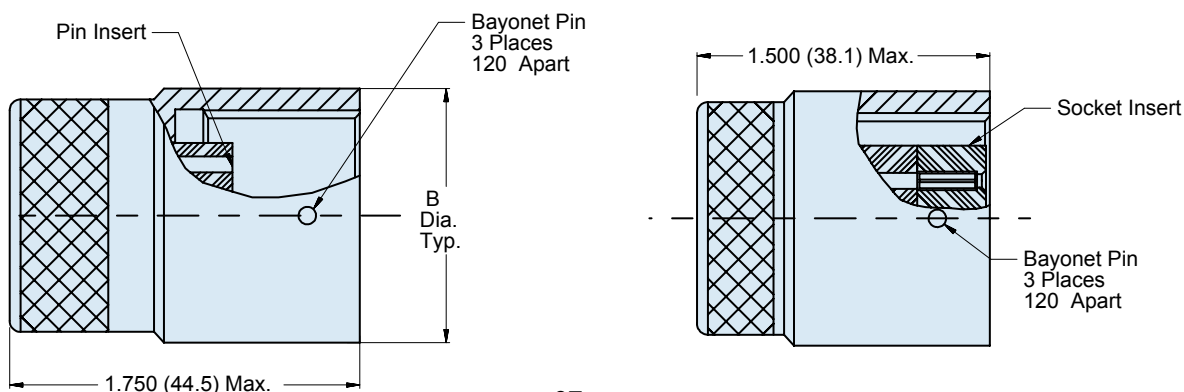
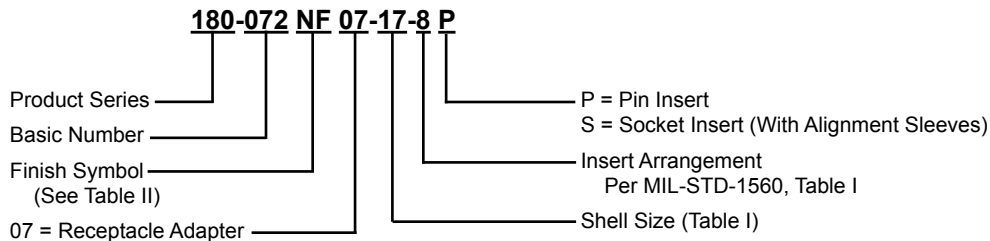

**TABLE I: SHELL SIZE AND
INSERT ARRANGEMENTS**

Shell Size & Insert Arrangement Dash No.	Shell Size Code Ref.	A Dia Max	B Dia Max
11-2	B	.964 (24.5)	.750 (19.1)
13-4	C	1.141 (29.0)	.875 (22.2)
15-5	D	1.266 (32.2)	1.000 (25.4)
15-97	D	1.266 (32.2)	1.000 (25.4)
17-8	E	1.391 (35.3)	1.187 (30.1)
19-11	F	1.500 (38.8)	1.250 (31.8)
21-16	G	1.625 (41.3)	1.375 (34.9)
23-21	H	1.750 (44.5)	1.500 (38.1)
23-99	H	1.750 (44.5)	1.500 (38.1)
25-20	J	1.875 (47.6)	1.625 (41.3)
25-29	J	1.875 (47.6)	1.625 (41.3)

TABLE II: FINISH

SYM	MATERIAL	FINISH
B	Aluminum	Cadmium Plate/Olive Drab
M	Aluminum	Electroless Nickel
NF	Aluminum	Cadmium/Olive Drab over Electroless Nickel (500-Hr. Salt Spray)
J	Aluminum	Iridite, Gold over Cadmium Plate over Electroless Nickel



**07
RECEPTACLE ASSEMBLY
U.S. PATENT NO. 5,960,137**

APPLICATION NOTES

1. Assembly identified with manufacturer's name and P/N, Space Permitting.
2. For Fiber Optic Test Probe Terminus See Glenair Drawing 181-006
3. Material/ Finish:
 - Barrel/ Shell- Al Alloy/ See Table II
 - Insert- Hi- Grade Engineering Thermoplastic/ N.A.
 - Alignment Sleeve- Zirconia Ceramic/ N.A.
 - Retaining Ring- Stainless Steel/ N.A.
 - Retaining Clips- Beryllium Copper/ N.A.
 - Lock Cap, Lock Nut- Al Alloy/ Black Anodize.
4. Metric dimensions (mm) are indicated in parentheses.

**TABLE I: SHELL SIZE AND
INSERT ARRANGEMENTS**

Shell Size & Insert Arrangement Dash No.	Shell Size Code Ref.	A Dia Max	B Dia Max
11-2	B	.964 (24.5)	.750 (19.1)
13-4	C	1.141 (29.0)	.875 (22.2)
15-5	D	1.266 (32.2)	1.000 (25.4)
15-97	D	1.266 (32.2)	1.000 (25.4)
17-8	E	1.391 (35.3)	1.187 (30.1)
19-11	F	1.500 (38.8)	1.250 (31.8)
21-16	G	1.625 (41.3)	1.375 (34.9)
23-21	H	1.750 (44.5)	1.500 (38.1)
23-99	H	1.750 (44.5)	1.500 (38.1)
25-20	J	1.875 (47.6)	1.625 (41.3)
25-29	J	1.875 (47.6)	1.625 (41.3)

TABLE II: FINISH

SYM	MATERIAL	FINISH
B	Aluminum	Cadmium Plate/Olive Drab
M	Aluminum	Electroless Nickel
NF	Aluminum	Cadmium/Olive Drab over Electroless Nickel (500-Hr. Salt Spray)
J	Aluminum	Iridite, Gold over Cadmium Plate over Electroless Nickel

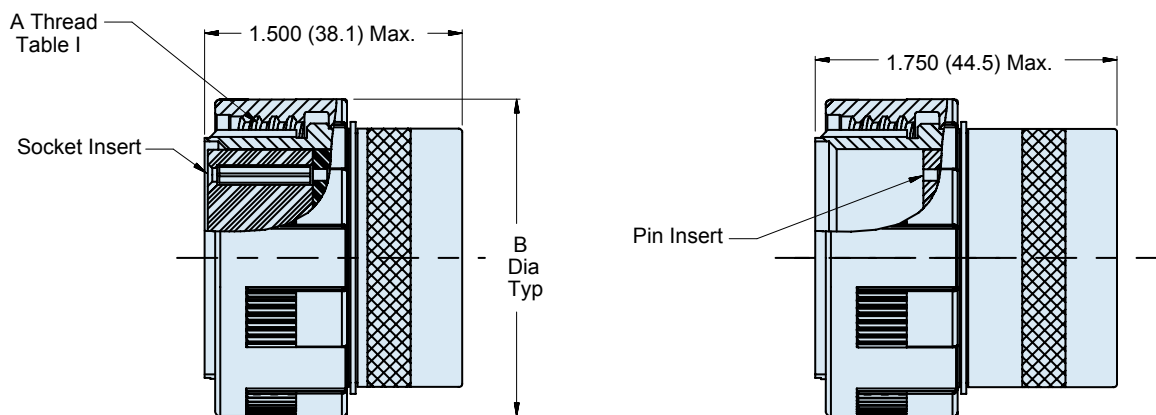
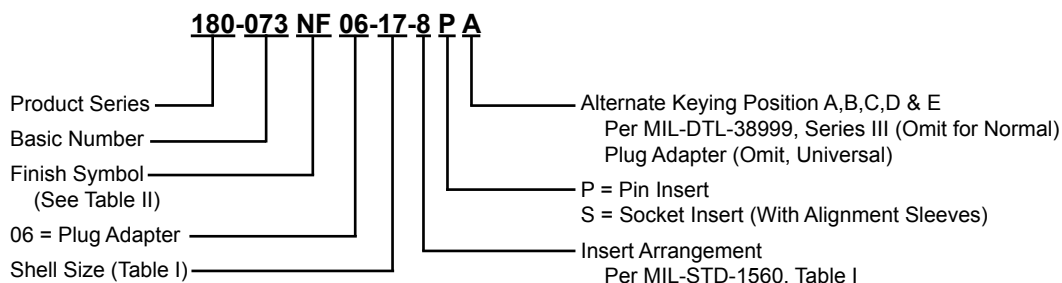

**06
PLUG ASSEMBLY**

APPLICATION NOTES

1. Assembly identified with manufacturer's name and P/N, Space Permitting.
2. For Fiber Optic Test Probe Assembly
See Glenair Drawing ABC54705
3. Material/ Finish:
 - Barrel/ Shell- Al Alloy/ See Table II
 - Insert, Coupling Nut- Hi- Grade Engineering Thermoplastic/ N.A.
 - Alignment Sleeve- Zirconia Ceramic/ N.A.
 - Retaining Ring- Stainless Steel/ N.A.
 - Retaining Clips- Beryllium Copper/ N.A.
 - Lock Nut- Al Alloy/ Black Anodize.
4. Metric dimensions (mm) are indicated in parentheses.

**180-073 (06 Plug)
Fiber Optic Test Adapter
With Special Insert Arrangement MIL-DTL-38999 Series III**



FRONT FACE OF PIN AND SOCKET INSERTS SHOWN, REAR SURFACE OPPOSITE

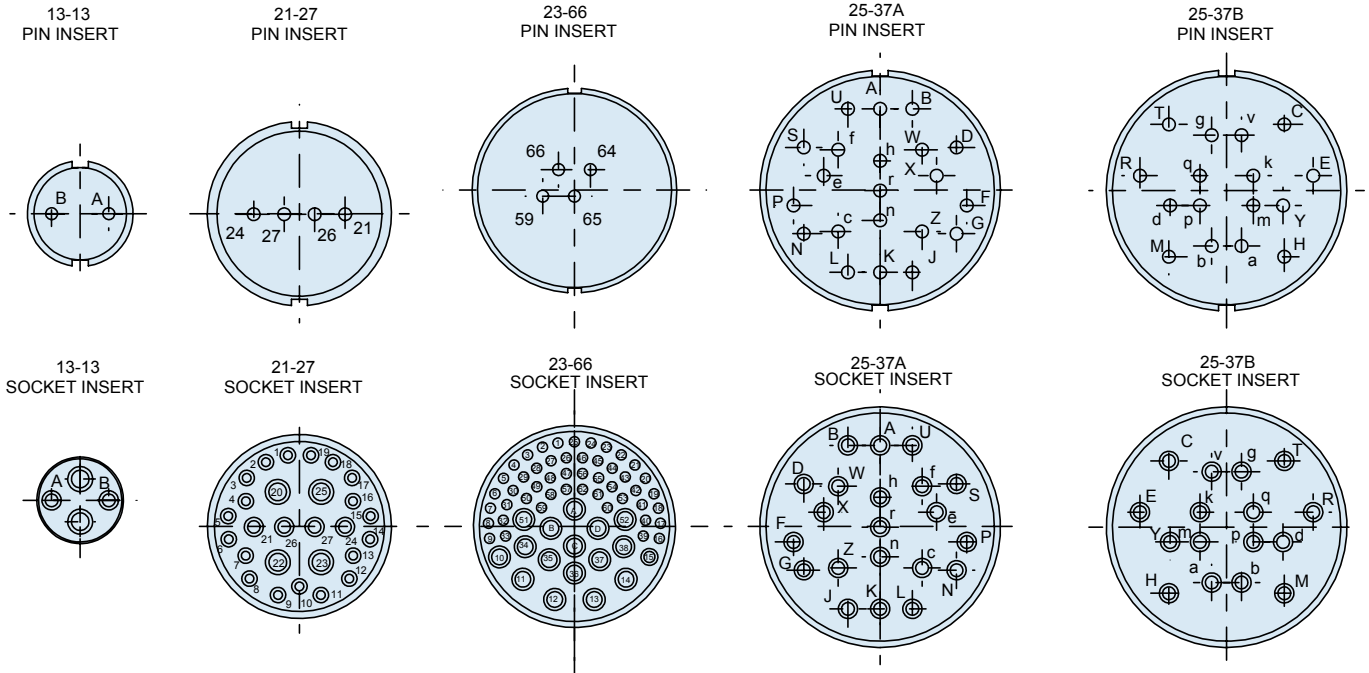
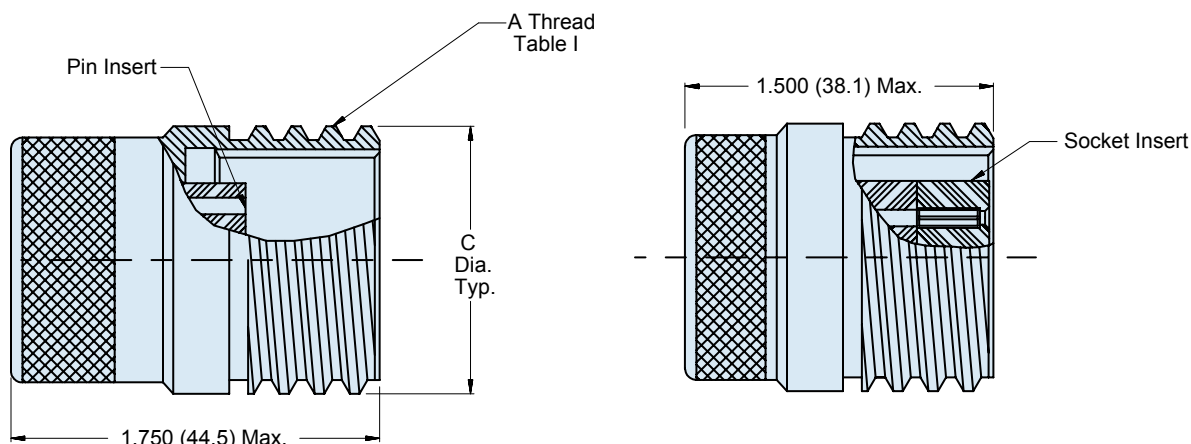
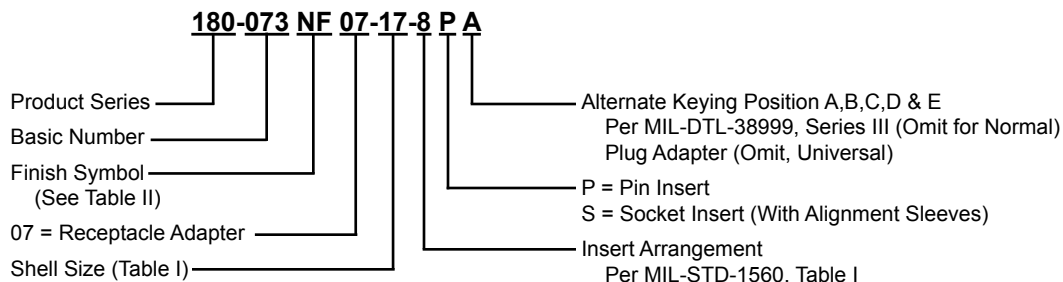

TABLE I: SHELL SIZE AND INSERT ARRANGEMENTS				
Shell Size & Insert Arrangement Dash No.	Shell Size Code Ref.	A Thread 0.1P-0.3L-TS-2	B Dia Max	C Dia Max
13-13	C	.875 (22.2)	1.141 (29.0)	.875 (22.2)
21-27	G	1.375 (34.9)	1.625 (41.3)	1.375 (34.9)
23-66*	H	1.500 (38.1)	1.750 (44.5)	1.500 (38.1)
25-37A**	J	1.625 (41.3)	1.875 (47.6)	1.625 (41.3)
25-37B**	J	1.625 (41.3)	1.875 (47.6)	1.625 (41.3)

*Shell Size 23 is made of 300 Series Stainless Steel.

**25-37 Insert Cavity spacing too close to Probe using one Adapter, two Adapters (25-37A and 25-37B) are therefore required to probe this Special Connector Insert Pattern.

TABLE II: FINISH		
SYM	MATERIAL	FINISH
B	Aluminum	Cadmium Plate/Olive Drab
M	Aluminum	Electroless Nickel
NF	Aluminum	Cadmium/Olive Drab over Electroless Nickel (500-Hr. Salt Spray)
N	Aluminum	Cadmium Plate/Olive Drab over Nickel Plate
Z1	Stainless Steel	Passivate



**07
RECEPTACLE ASSEMBLY**

APPLICATION NOTES

1. Assembly identified with manufacturer's name and P/N, Space Permitting.
2. For Fiber Optic Test Probe Assembly See Glenair Drawing ABC54705
3. Material/ Finish:
 - Barrel/ Shell- Al Alloy/ See Table II
 - Insert, Coupling Nut- Hi- Grade Engineering Thermoplastic/ N.A.
 - Alignment Sleeve- Zirconia Ceramic/ N.A.
 - Retaining Ring- Stainless Steel/ N.A.
 - Retaining Clips- Beryllium Copper/ N.A.
 - Lock Nut- Al Alloy/ Black Anodize.
4. Metric dimensions (mm) are indicated in parentheses.

**180-073 (07 Receptacle)
Fiber Optic Test Adapter
With Special Insert Arrangement MIL-DTL-38999 Series III**



FRONT FACE OF PIN AND SOCKET INSERTS SHOWN, REAR SURFACE OPPOSITE

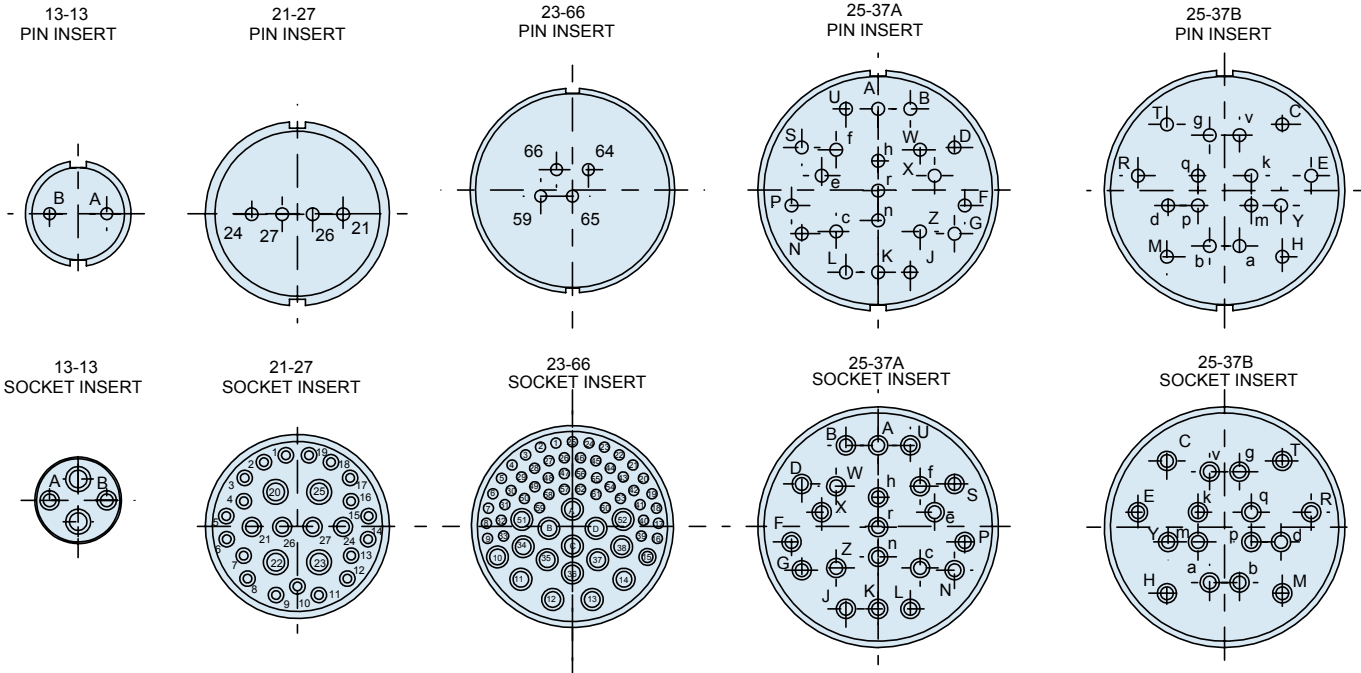
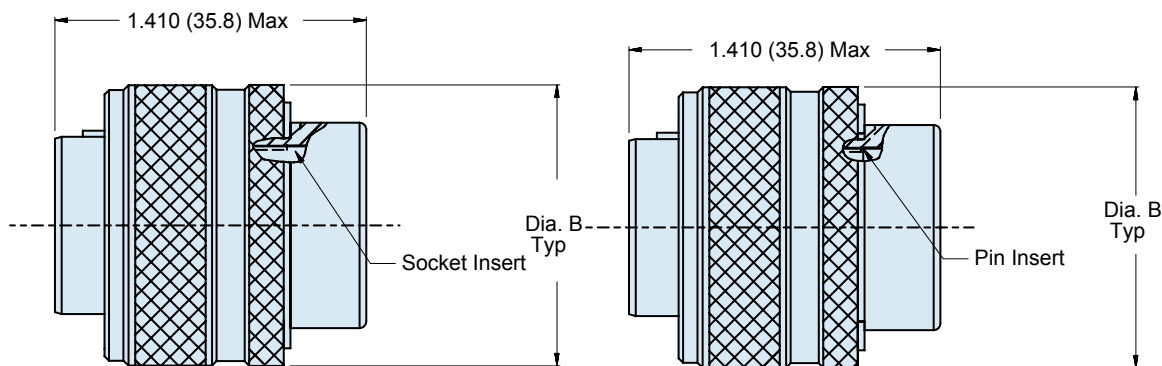
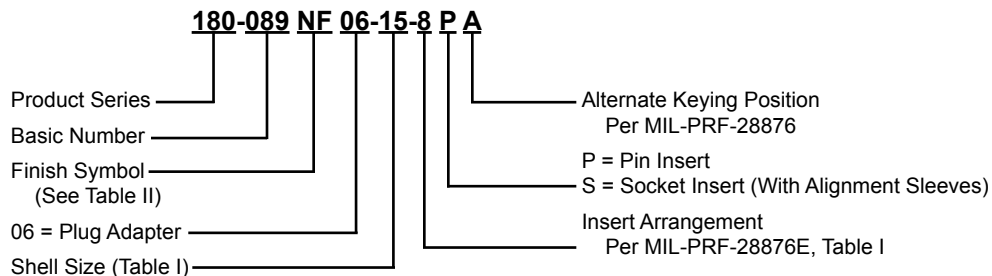

TABLE I: SHELL SIZE AND INSERT ARRANGEMENTS				
Shell Size & Insert Arrangement Dash No.	Shell Size Code Ref.	A Thread 0.1P-0.3L-TS-2	B Dia Max	C Dia Max
13-13	C	.875 (22.2)	1.141 (29.0)	.875 (22.2)
21-27	G	1.375 (34.9)	1.625 (41.3)	1.375 (34.9)
23-66*	H	1.500 (38.1)	1.750 (44.5)	1.500 (38.1)
25-37A**	J	1.625 (41.3)	1.875 (47.6)	1.625 (41.3)
25-37B**	J	1.625 (41.3)	1.875 (47.6)	1.625 (41.3)

*Shell Size 23 is made of 300 Series Stainless Steel.

**25-37 Insert Cavity spacing too close to Probe using one Adapter, two Adapters (25-37A and 25-37B) are therefore required to probe this Special Connector Insert Pattern.

TABLE II: FINISH		
SYM	MATERIAL	FINISH
B	Aluminum	Cadmium Plate/Olive Drab
M	Aluminum	Electroless Nickel
NF	Aluminum	Cadmium/Olive Drab over Electroless Nickel (500-Hr. Salt Spray)
N	Aluminum	Cadmium Plate/Olive Drab over Nickel Plate
Z1	Stainless Steel	Passivate



**06
PLUG ASSEMBLY**

APPLICATION NOTES

1. Material/ Finish:
 Barrel/ Shell, Lock Nut- Al Alloy/ See Table II.
 Insert, Coupling Nut- Hi Grade Engineering Thermoplastic/ N.A.
 Alignment Sleeve- Zirconia Ceramic/ N.A.
 Retaining Ring- Stainless Steel/ N.A.
 Retaining Clips- Beryllium Copper/ N.A.
 Lock Cap- Black Anodize.
2. For Fiber Optic Test Probe Terminus
 See Glenair Drawing 181-027.
3. Assembly identified with manufacturer's
 name and P/N, space permitting.
4. Metric dimensions (mm) are indicated in parentheses.

180-089 (06 Plug)
Fiber Optic Test Adapter
MIL-PRF-28876

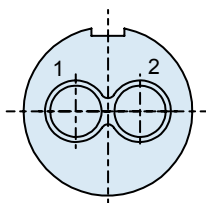

11-2
SOCKET FACE

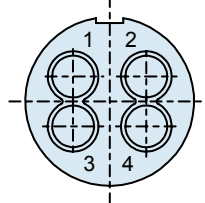

13-4
SOCKET FACE

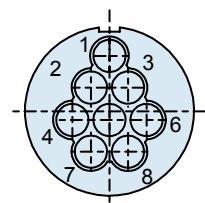

15-8
SOCKET FACE

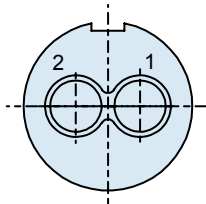

11-2
PIN FACE

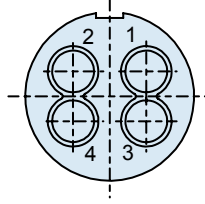

13-4
PIN FACE

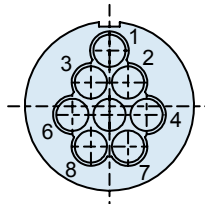

15-8
PIN FACE

TABLE I: SHELL SIZE

Shell Size	Shell Size Code Ref.	Number of Terminus Cavities	A Thread 0.1P-0.2L-DS	B Dia Max
11	A	2	.750 (19.1)	1.020 (25.9)
13	B	4	.875 (22.2)	1.150 (29.2)
15	C	6	1.062 (27.0)	1.275 (32.4)
15	C	8	1.062 (27.0)	1.275 (32.4)
23	F	18	1.500 (38.1)	1.400 (35.6)
23	F	31	1.500 (38.1)	1.400 (35.6)

TABLE II: FINISH

SYM	MATERIAL	FINISH
B	Aluminum	Cadmium Plate/Olive Drab
M	Aluminum	Electroless Nickel
N	Aluminum	Cadmium Plate/Olive Drab over Nickel Plate
NF	Aluminum	Cadmium/Olive Drab over Electroless Nickel (500-Hr. Salt Spray)
J	Aluminum	Iridite, Gold over Cadmium Plate over Electroless Nickel

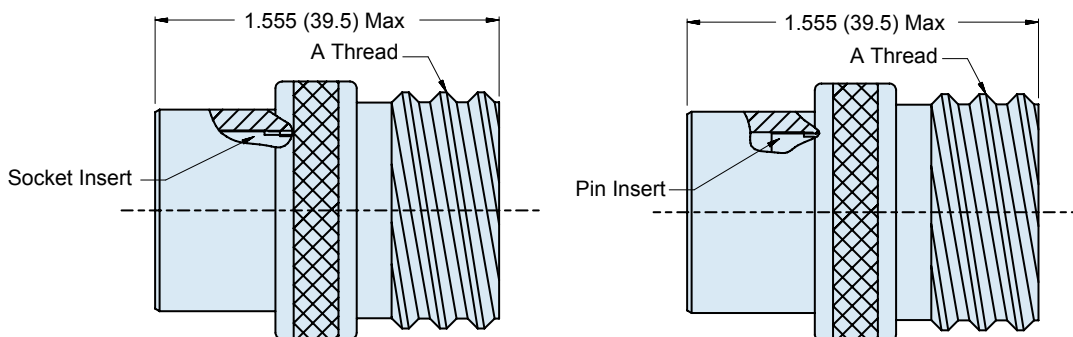
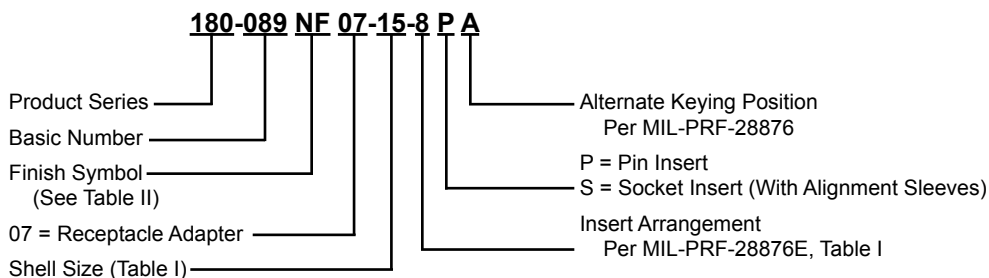

**07
RECEPTACLE ASSEMBLY**

APPLICATION NOTES

1. Material/ Finish:
Barrel/ Shell, Lock Nut- Al Alloy/ See Table II.
Insert, Coupling Nut- Hi Grade Engineering Thermoplastic/ N.A.
Alignment Sleeve- Zirconia Ceramic/ N.A.
Retaining Ring- Stainless Steel/ N.A.
Retaining Clips- Beryllium Copper/ N.A.
Lock Cap- Black Anodize.
2. For Fiber Optic Test Probe Terminus
See Glenair Drawing 181-027.
3. Assembly identified with manufacturer's name and P/N, space permitting.
4. Metric dimensions (mm) are indicated in parentheses.

180-089 (07 Receptacle)
Fiber Optic Test Adapter
MIL-PRF-28876

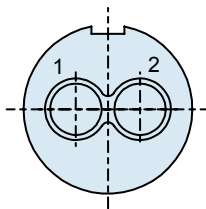

11-2
SOCKET FACE

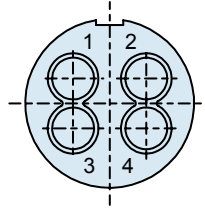

13-4
SOCKET FACE

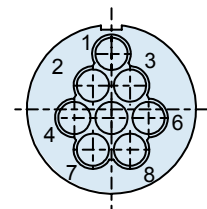

15-8
SOCKET FACE

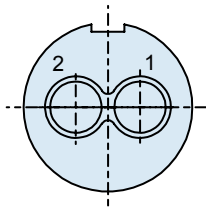

11-2
PIN FACE

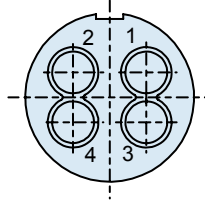

13-4
PIN FACE

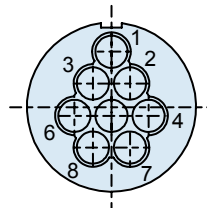

15-8
PIN FACE

TABLE I: SHELL SIZE

Shell Size	Shell Size Code Ref.	Number of Terminus Cavities	A Thread 0.1P-0.2L-DS	B Dia Max
11	A	2	.750 (19.1)	1.020 (25.9)
13	B	4	.875 (22.2)	1.150 (29.2)
15	C	6	1.062 (27.0)	1.275 (32.4)
15	C	8	1.062 (27.0)	1.275 (32.4)
23	F	18	1.500 (38.1)	1.400 (35.6)
23	F	31	1.500 (38.1)	1.400 (35.6)

TABLE II: FINISH

SYM	MATERIAL	FINISH
B	Aluminum	Cadmium Plate/Olive Drab
M	Aluminum	Electroless Nickel
N	Aluminum	Cadmium Plate/Olive Drab over Nickel Plate
NF	Aluminum	Cadmium/Olive Drab over Electroless Nickel (500-Hr. Salt Spray)
J	Aluminum	Iridite, Gold over Cadmium Plate over Electroless Nickel

180-102 (06 Plug) Fiber Optic Probe Adapter

180-102 NF 06-1

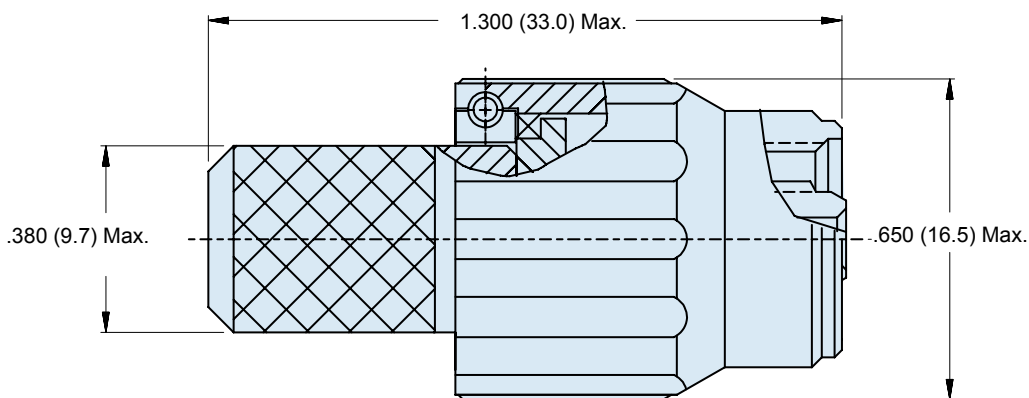
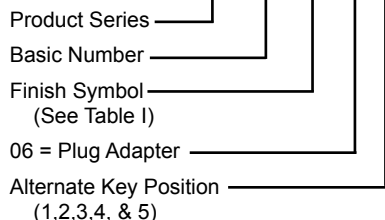

PLUG ASSEMBLY-06

APPLICATION NOTES

1. Assembly identified with manufacturer's name and P/N, space permitting.
2. For Fiber Optic Test Probe Terminus See Glenair drawing 181-006.
3. Material/ Finish:
Shell/ Plug- Al Alloy/ See Table I
Rear Body- Al Alloy/ See Table I
Coupling Nut- Al Alloy/ See Table I
Retaining Clips- Beryllium Copper/ N.A.
Spring- Stainless Steel
Wire Retention- Stainless Steel
O-Ring- Fluorosilicone
4. Metric dimensions (mm) are indicated in parentheses.

TABLE I: FINISH

SYM	MATERIAL	FINISH
M	Aluminum	Electroless Nickel
NF	Aluminum	Cadmium/Olive Drab over Electroless Nickel (500-Hr. Salt Spray)
C	Aluminum	Black Anodize

180-102 (07 Receptacle) Fiber Optic Probe Adapter

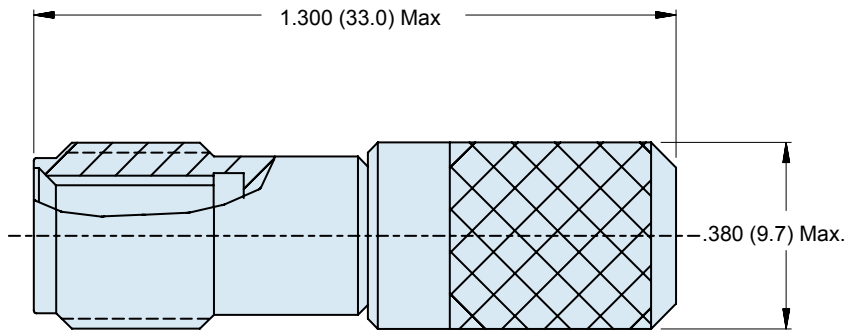
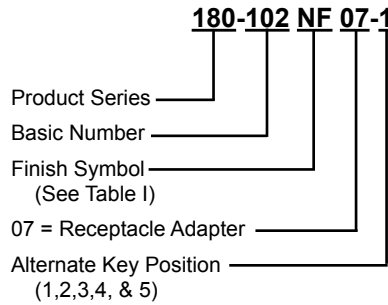

RECEPTACLE ASSEMBLY-07

APPLICATION NOTES

1. Assembly identified with manufacturer's name and P/N, space permitting.
2. For Fiber Optic Test Probe Terminus See Glenair drawing 181-006.
3. Material/ Finish:
 Shell/ Plug- Al Alloy/ See Table I
 Rear Body- Al Alloy/ See Table I
 Coupling Nut- Al Alloy/ See Table I
 Retaining Clips- Beryllium Copper/ N.A.
 Spring- Stainless Steel
 Wire Retention- Stainless Steel
 O-Ring- Fluorosilicone
4. Metric dimensions (mm) are indicated in parentheses.

TABLE I: FINISH

SYM	MATERIAL	FINISH
M	Aluminum	Electroless Nickel
NF	Aluminum	Cadmium/Olive Drab over Electroless Nickel (500-Hr. Salt Spray)
C	Aluminum	Black Anodize

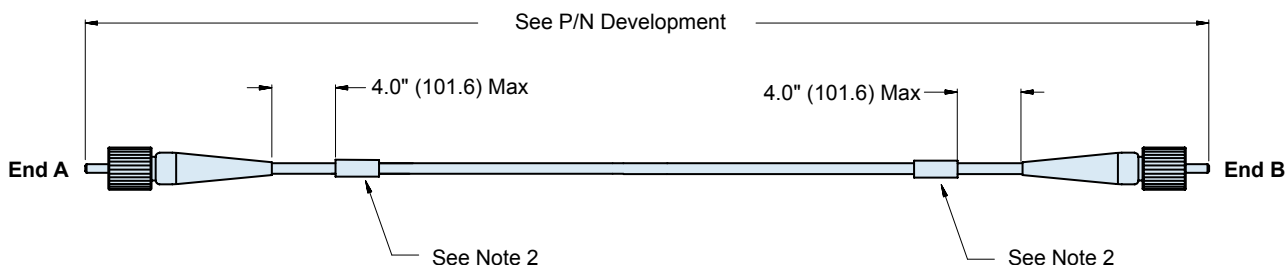
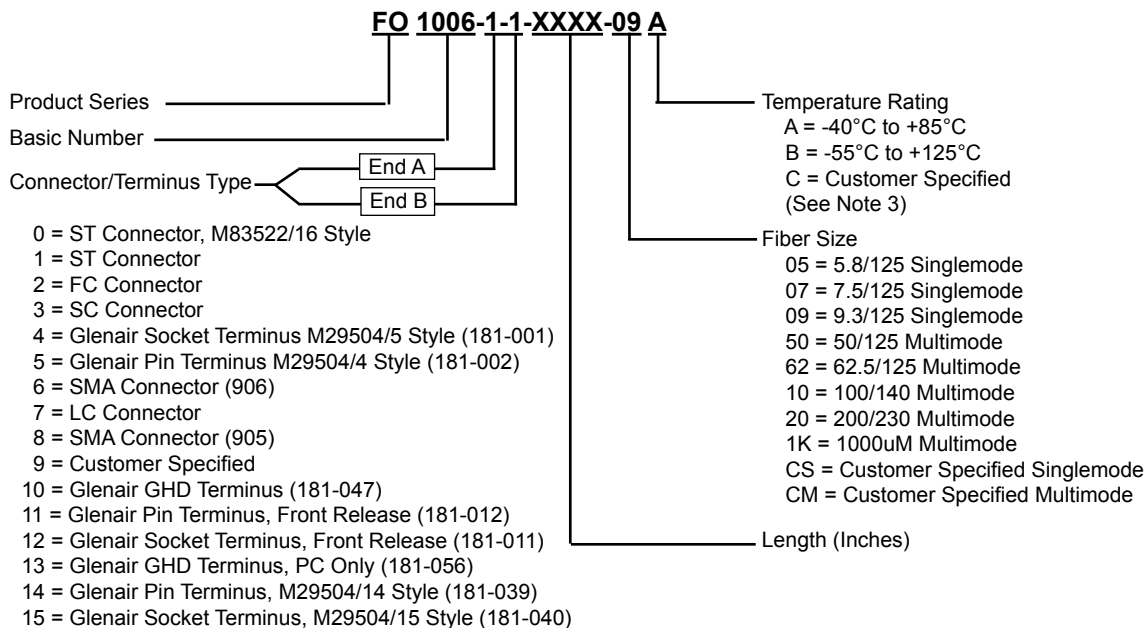

APPLICATION NOTES

- Optical performance: insertion loss to be less than 1.5 dB when measured at 850 nm wavelength for Multimode and 1310 nm wavelength for Singlemode.
- Assy is marked with the Glenair PN in two places.
- "A" Temperature rating use TRA-BOND F113 Epoxy.
"B" Temperature rating use EPO-TEK 353ND Epoxy.
"C" Temperature rating as per customer specification.
- Metric dimensions (mm) are indicated in parentheses.
- For angle polish, add "A" to end of Connector/Terminus Type Number (otherwise omit). Type numbers, 4, 5, 6, 8, 11, 12, 13, 14, and 15 do not allow angle polish.
- For military qualified product, add "M" to end of Connector/Terminus Type number (otherwise omit). Type number 4, 5, 14, and 15 only.

STANDARD TOLERANCE

LENGTH	TOLERANCE
5 in to 2 ft.	+1 in -0
2 to 10 ft.	+3 in -0
10 to 50 ft.	+6 in -0
50 to 100 ft.	+1 ft -0
100 ft. and up	+2 ft -0

FO1007 Glenair Fiber Optic Patch Cords Duplex



FO 1007-1-1-XXXX-09 A X

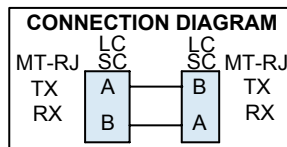
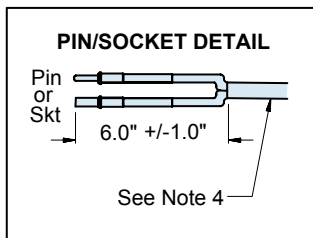
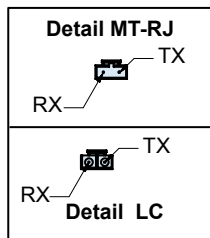
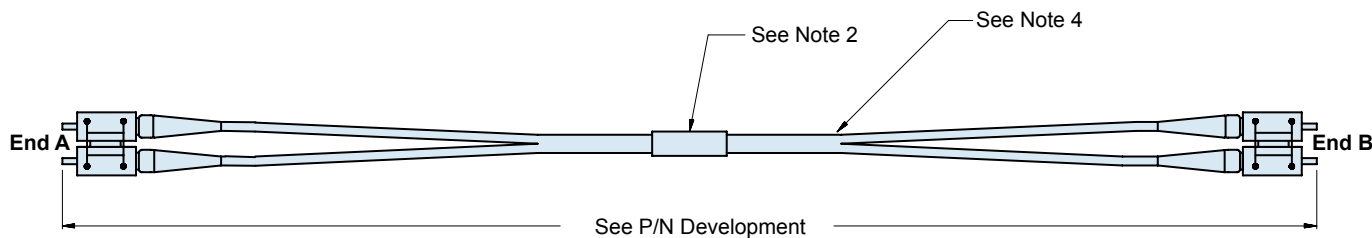
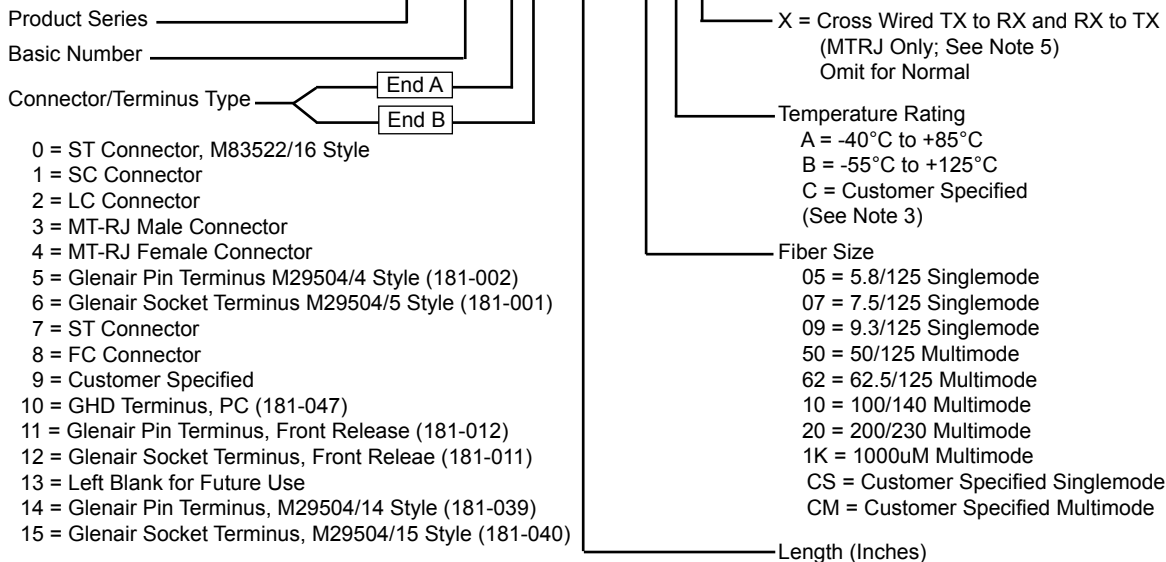

STANDARD TOLERANCE	
LENGTH	TOLERANCE
5 in - 2 ft.	+1 in -0
2 to 10 ft.	+3 in -0
10 to 50 ft.	+6 in -0
50 to 100 ft.	+1 ft -0
100 ft. and up	+2 ft -0

APPLICATION NOTES

- Optical performance: insertion loss to be less than 1.5 dB when measured at 850 nm wavelength for Multimode and 1310 nm wavelength for Singlemode.
- Assy is marked with the Glenair P/N, located approx. in the center.
- "A" Temperature rating use TRA-BOND F113 Epoxy.
"B" Temperature rating use EPO-TEK 353ND Epoxy.
"C" Temperature rating as per customer specification.
- When using simplex cable apply heat shrink as needed to combine both fibers leaving approx. 6.0" on each end open.
- MTRJ'S are connected per connections diagram unless cross wired is specified in P/N description.
- Metric dimensions (mm) are indicated in parentheses.
- For angle polish, add "A" to end of Connector/Terminus Type Number (otherwise omit). Type numbers, 4, 5, 11, 12, 14, and 15 do not allow angle polish.
- For military qualified product, add "M" to end of Connector/Terminus Type number (otherwise omit). Type number 4, 5, 14, and 15 only.

Sure, Test Harnesses Are a Great Way to Troubleshoot Fiber Optic Cables

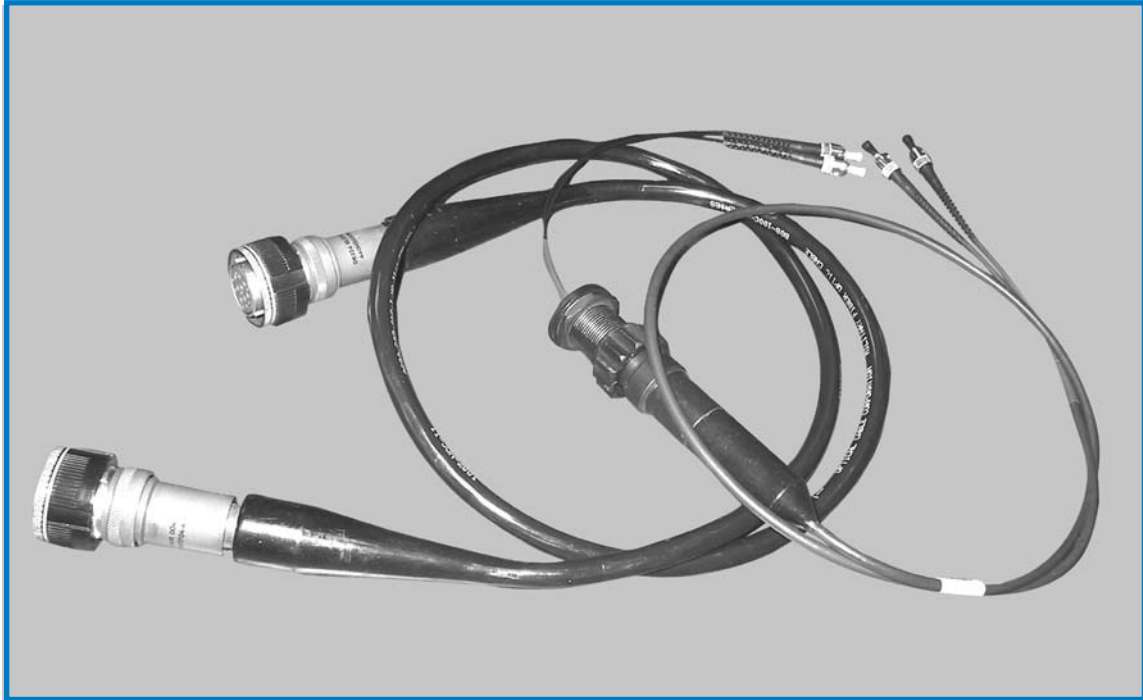

Until You Foul-Up the Contacts and Have to Throw the Whole Thing Away

Glenair has a better idea: Our fast and efficient Test Probe and Connector Adapter Kits. The patented technology eliminates the need to produce and maintain expensive optical test harnesses which are so easily contaminated in normal use. With the Glenair Test Probe, the performance

of each channel in a fiber optic cable can be quickly determined using an easy to clean and calibrate jumper. So say *adios* to the expensive test harnesses of the past, and *hola* to the Glenair Test Probe of the future. They'll save you time, money and headaches.



1211 Air Way
Glendale, California 91201-2497
Telephone: 818-247-6000 ■ Facsimilie: 818-500-9912 ■ EMail: sales@glenair.com

United States ■ United Kingdom ■ Germany ■ Nordic ■ France ■ Italy ■ Spain ■ Japan

www.glenair.com



PRODUCT FEATURES

- Complete Termination Toolkits
- Video Bore Scope Inspection Toolkits
- CleanBlast® Cleaning System
- Cleaning Swabs
- Polishing Tools
- Specialty Tooling for All Fiber Optic Operations
- Band-It® Shield Termination System

Glenair: One Stop Shopping for All Your Fiber Optic Interconnection System Tooling Requirements

The Right Fiber Optic Tool for the Job

Fiber optic connectors are designed to be connected and disconnected many times without affecting the optical performance of the fiber circuit. The key to this performance is the error-free termination of the contact terminus to the fiber circuit—a task which requires the use of a wide range of specialized tooling. Glenair's extensive experience in building fiber optic interconnect cables has enabled us to select the right tools for each step in the termination and assembly process. Our Fiber Optic Termination and Test Probe Kits allow field technicians the convenience of completing final termination of precision termini on location for easy and efficient cable routing and installation. Each kit contains pin and socket polishing tools, jacket strippers, shears, scribes—literally all the tools and supplies required for ongoing termination and test of fiber optic systems. Polishing tools are also sold separately for factory use or as replacement parts in field termination kits.

The Band-It® Shield Termination System

The Band-It® Clamping System provides quick, easy and highly-reliable termination of braided shielding or fabric braid. Glenair has designed banding platforms into a number of our specialized fiber optic backshells and conduit adapters. Individual clamping tools, bands and kits are available.

Inspection and Cleaning Systems

Glenair has selected the industry's best Video Bore Scope Inspection System for efficient troubleshooting of fiber media. The Glenair video inspection system supplies everything you need to quickly and conveniently inspect and clean butt-jointed fiber optic contacts. Optional add-ons enable turnkey integration with computer desktops, digital cameras and powerful optical test software. The CleanBlast® system creates a laminar flow of a highly filtered gas across the surface of the fiber. A solvent is then introduced and atomized to create a cleaning mist that leaves the fiber contamination free, ensuring that your cable is serving at its optimal performance.

187-017

Glenair Fiber Optic Termination Kit for MIL-PRF-29504/4 & /5 Termini (181-001 & 002)



- Turn-Key Termination of MIL-PRF-29504/04 and /05 Fiber Termini
- Singlemode or Multimode
- 110 Volt or 220 Volt
- Complete Kit With All Tools, Instruments and Consumables
 - Power Meter
 - LED Source
 - 200X Microscope
 - Polishing Media
 - Curing Oven
 - Hand Tools
 - Epoxies, Wipes and Swabs

Portable “Fiber Optic Lab In A Box” for Field Termination and Repair of D38999 Optical Interconnects

Our termination kit allows field technicians the convenience of on-site optical fiber termination. Each kit contains jacket strippers, polishing tools, hand tools, light source, power meter and microscope as well as a full complement of consumables including epoxy, polishing media, swabs and adhesives.

Key Components



**Optical Power
Meter
Battery-Operated**



**LED Source
Battery-Operated**



Curing Oven

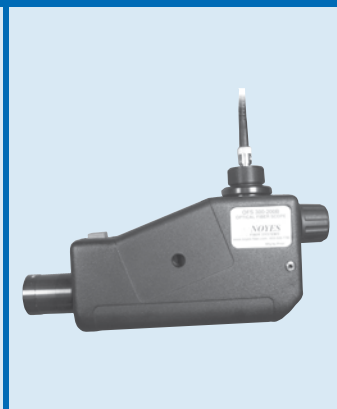

**200X Microscope
Battery-Operated**

187-017
Glenair Fiber Optic Termination Kit
for MIL-PRF-29504/4 & /5 Termini (181-001 & 002)



187-017 110-MM

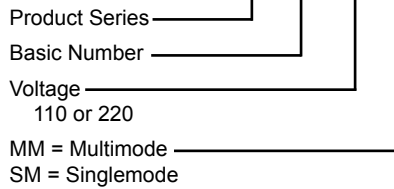

**FOR USE
 WITH
 MIL-PRF-29504/4 & /5
 TERMINI**



PARTS LIST		
Item No.	Part Description	Quantity
1	Terminus Procedure (Laminated)	1
2	Pin Termini for 62.5/125 Fiber (181-002-126)	10
3	Socket Termini for 62.5/125 Fiber (181-001-126)	10
4	Polishing Tool, Pin Terminus (182-001P)	1
5	Polishing Tool, Socket Terminus (182-001S)	1
6	Terminus Swabs (Glenair 50/Pkg) (187-024)	1
7	Spare Ceramic Alignment Sleeve (181-001-S)	10
8	Plastic Dust Cover, ST (2.5 mm Dia) (F.I.S.)	10
9	Plastic Dust Cover, Termini (.062" Dia) (CAPLUG)	10
10	Hard Shell Tool Case with Foam (Fibertron)	1
11	Custom Diecut Foam Insert (CHI Case)	1
12	Multi-Cure Oven with Curing Block (9050) (Fibertron)	1
13	D38999 Ferrules Curing Block (Fibertron)	1
14	Microscope, 200X (Noyes)	1
15	Microscope Adapter for D38999 (Noyes)	1
16	Scribe, Fiber (Fibertron)	1
17	Kevlar Shear (Claus)	1
18	No-Nic Stripper, Gold (Claus)	1
19	No-Nic Stripper, Blue (Claus)	1
20	Autocleaner (Netpec)	1
21	Jacket Stripper, T5 (Claus)	1
22	Alcohol Dispenser, 4 Oz. (F.I.S.)	1
23	Ruler, 6" (Fibertron)	1
24	Diamond Polishing Film, 9 Microm, 6 x 6 (3M)	4
25	Diamond Polishing Film, 3 Micron, 6 x 6 (3M)	6
26	Diamond Polishing Film, 1 Micron, 6 x 6 (3M)	6
27	Resilient Rubber Pad (3M)	1
28	Glass Polishing Plate, 8" x 8" (Fibertron)	1
29	Cleaning Wire (F.I.S.)	1
30	Compressed Air (Fibertron)	1
31	Kim-Wipes (Kimberly-Clark)	1
32	Continuity Test, ST (F.I.S.)	1
33	Epoxy Applicator (Syringe) (Fibertron)	10
34	Mini Foam Swab, 2.5 mm (F.I.S.)	50
35	Tra-Bound Adhesive (Tra-Con)	10
36	Insert/Removal Tool	5
37	LED Source W/D38999 Aprt, 1300nm Wvlngh (Rifocs)	1
38	Power Meter W/D38999 Aprt, 1300nm Wvlngh (Rifocs)	1
39	ST Adapter for Power meter (Rifocs)	1
40	ST Adapter for LED Source (Rifocs)	1
41	Instant Adhesive (Loctite Corp.)	1



- **Field/Bench Use System Includes Video Display Unit, Inspection Camera and Standard 2.5 mm & 1.25 mm Patchcord Inspection Tips**
- **Tips available Use with all Common F/O Connector Types: SC, LC, ST, and FC *plus* Mil-Dtl-38999 and Small Form Factor Connectors**
- **200X and 400X Magnification**
- **Built-in NiMH Rechargeable Battery with Automatic Shut-off Function**
- **Rugged Watertight Case**

Glenair Video Inspection System Provides The Ultimate Solution to Field Maintenance of Fiber Optic Systems

Dirty or contaminated fiber optic contacts (termini) can seriously degrade the performance of a fiber optic system. But inspecting individual contacts in complex connector devices such as bulkhead feed-throughs and multi-channel Mil-Spec connectors can be a difficult and time-consuming task. The Glenair video inspection system supplies everything you need to quickly and conveniently inspect and clean butt-jointed fiber optic contacts. Optional add-ons enable turnkey integration with computer desktops, digital cameras and powerful optical test software.

How To Order

- Basic Part Number **GBS1000-U** Includes:
- Handheld Inspection Monitor
 - Inspection Probe (200x & 400x)
 - Portable Ruggedized Carrying Case
 - Glenair Swabs
- Optional Quick Capture USB Module for Computer Inspection and Video Capture.



Fiber check software can be downloaded from:
<http://www.westoverfiber.com>

GBS1000 and GBS1001 Portable Fiber Optic Video Bore Scope Inspection System



GBS1000 SPECIFICATIONS	
Dimensions	1.8" W x 1.7" H x 5.5" L
Weight	4.08 oz / 115.6 gms
Video Output	NTSC or PAL
Light Source	Blue LED 1000,000+ hour life
Lighting Technique	Coaxial
Attenuation Filter	2 mm thick Schott KG1
Camera type	.33" CCD

GBS1001 SPECIFICATIONS	
Weight	.11 Kg / .25 lb
Resolution	Better than 1.5 Microns
Cable	Integrated USB 2.0 coil cable 2.5' relaxed, 10.5' fully extended
Certification	CE
Warranty	1 year

GBS1001 Inspection Probe with USB Adapter and Fiber Chek 2 Software



GBS1001

Basic Part Number
Includes:

- Inspection Probe with USB Adapter
- Fiber Chek 2 Software

The GBS1001 is the only inspection probe today with a high resolution, all digital sensor and USB2 video stream which delivers high-resolution uncompressed images directly to your personal computer.

Fiber Chek Software Fiber Optic Analysis Program

Fiber Chek is an integrated hardware/software package engineered with the single purpose of critically and consistently grading fiber end-faces. Works hand in hand with the Quick Capture Analog Probe for visual inspection, taking pictures and testing fibers.

- Automatic debris and defect detection, including fine scratches
- Measures epoxy ring for out-of-tolerance conditions
- Inspection results, including image data, can be printed or archived
- Utilizes industry standards or user defined threshold settings

APPLICATION NOTES

1. Glenair's handheld Bore Scope is a small, lightweight video microscope used to examine fiber optic end-faces. The GBS1000 displays a clear and concise live image with the ability to view fibers at either 200x or 400x magnifications.
2. The Quick Capture GBS1000-U USB Module can be added to the GBS1000. This valuable item allows the user to inspect and capture fiber end-faces on your PC. Works great with Fiber Chek software to inspect, test and capture images. To order separately, use part number GMP-002.
3. The dual magnification mode inherent in all Fiber Chek 2 platforms provides a large, easily centered image during handheld focusing. This greatly simplifies your ability to achieve a quality image. A high-magnification image is acquired, analyzed, and graded.
4. Fiber Chek 2 software can analyze several zones of the fiber end-face.



- **Faster, More Effective and Less Costly than using Swabs or other Cleaning Methods**
- **Excellent at Removing—Instead of Spreading—Debris and Oils around the Ferrule Surface**
- **Complete Selection of Tips Available**
- **Cost per Cleaning Cycle: One Cent!**
- **Rugged Watertight Case**
- **Optional Add-Ons for Advanced Optical Testing of MIL-PRF-29504 Termini with Quick Capture Analog Probe (6-4 pin Converter) and FiberChek Software for Quick Capture Capability on Your PC.**

Glenair's CleanBlast® Systems Provide Rapid, Controlled Cleaning and Removal of Contamination from Fiber Optic End-Faces

The CleanBlast® system creates a laminar flow of a highly filtered gas across the surface of the fiber. A solvent is then introduced and atomized to create a cleaning mist that leaves the fiber contamination free (MSDS data sheet is available), ensuring that your cable is serving at its optimal performance.

Complete CleanBlast® Inspection System

GCB1000-U

Basic Part Number
Includes:

- Portable CleanBlast® with LCD Monitor and Inspection Probe in Ruggedized Case
- 2.5 mm and 1.25 mm Patch Cord Inspection Tips
- Universal 2.5 mm Bulkhead Cleaning Tip
- Glenair Swabs

Optional Quick Capture
Analog Probe with
6 Pin to 4 Pin Converter
(Omit for None)

CleanBlast® Basic Kit

GCB2000

Basic Part Number
Includes:

- Portable CleanBlast®
- Glenair Swabs

Laboratory Bench Model

GCB3000-M

Basic Part Number
Includes:

- Universal 2.5 mm Bulkhead Cleaning Tip
- Glenair Swabs

Optional Digital Mounting
Monitor with Inspection Probe
and 2.5 mm & 1.25 mm Patch
Cord Inspection Tips

Fiber check software can be downloaded from:
<http://www.westoverfiber.com>

**GCB1000, GCB2000 and GCB3000
Fiber Optic CleanBlast® Cleaning Systems
for Fiber Optic Connectors**



GCB1000 and GCB2000 SPECIFICATIONS	
Power Requirements	110 VAC-220 VAC, 2 amp
Dimensions	16"L x 13"W x 7"D
Weight	21 lb
Air Source	40 psi Internal Compressor
Cleaning Cycle Time	5 seconds
Certification	CE Approved

GCB3000 SPECIFICATIONS	
Power Requirements	110 VAC-220 VAC, 2 amp
Dimensions	8"L x 9"W x 7"D
Weight	12 lb
Air Source	External, compressed air or nitrogen; regulated between 60 – 250 psi
Cleaning Cycle Time	.8 seconds
Certification	CE Approved

**Fiber Chek Software
Fiber Optic Analysis Program**

Fiber Chek is an integrated hardware/software package engineered with the single purpose of critically and consistently grading fiber end-faces. Works hand in hand with the Quick Capture Analog Probe for visual inspection, taking pictures and testing fibers on your PC.

- Automatic debris and defect detection, including fine scratches
- Measures epoxy ring for out-of-tolerance conditions
- Inspection results, including image data, can be printed or archived
- Utilizes industry standards or user defined threshold settings

GTK1000

Glenair Fiber Optic Testing Kit for Front Release 181-011 & -012 Termini

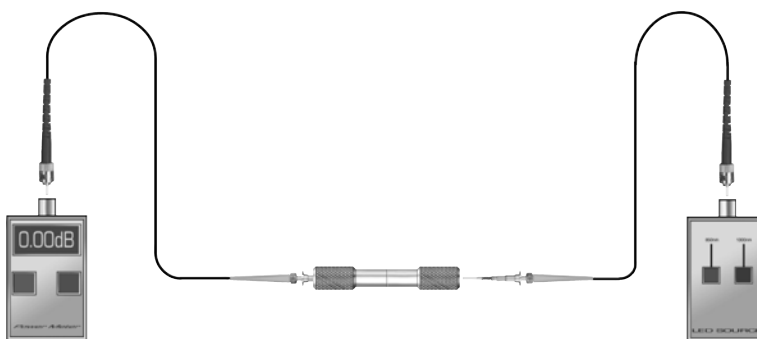
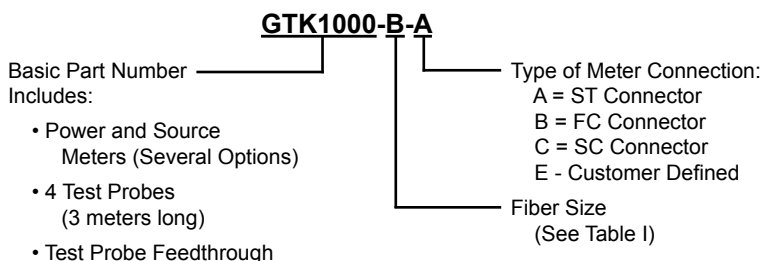

TABLE I: FIBER SIZE

Symbol	Fiber Size
A	100/140u
B	62.5/125u
C	50/125u
D	200/300u
E	9.3 Singlemode
F	Customer Defined

APPLICATION NOTES

1. Traditional optical test harnesses are expensive and easily contaminated in normal use. Glenair's test probe, in conjunction with our precise-mating test adapter, offers a complete solution to optical test and measurement. The GTK-1000 comes with a power meter, source meter, test probes and a test probe calibrator.
2. For accurate results, the test probe calibrator will "zero out" your meters.
3. Glenair's patented test probe design provides less than 1.0 dB insertion loss, are used with test probe adapters and a calibration feedthrough, and accommodates all standard fiber sizes and several connection options.

187-018
Glenair Fiber Optic Termination Kit
for Front Release 181-011 & -012 Termini

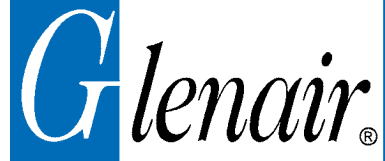

PARTS LIST		
Item No.	Part Description	Quantity
1	181-011 & 181-012 Terminus Procedure (Laminated)	1
2	Pin Termini for 62.5/125 Fiber (181-012-126)	10
3	Socket Termini for 62.5/125 Fiber (181-011-126)	10
4	Polishing Tool, Pin, Front Release (182-005P)	1
5	Polishing Tool, Socket, Front Release (182-005S)	1
6	Terminus Swabs (Glenair 50/Pkg) (187-045)	1
7	Plastic Dust Cover, ST (2.5 mm Dia) (F.I.S.)	10
8	Plastic Dust Cover, Termini (.062" Dia) (CAPLUG)	10
9	Hard Shell Tool Case with Foam (Fibertron)	1
10	Custom Diecut Foam Insert (CHI Case)	1
11	Multi-Cure Oven with Curing Block (9050) (Fibertron)	1
12	D38999 Ferrules Curing Block (Fibertron)	1
13	Microscope, 200X (Noyes)	1
14	Microscope Adapter for D38999 (Noyes)	1
15	Scribe, Fiber (Fibertron)	1
16	Kevlar Shear (Clauss)	1
17	No-Nic Stripper, Gold (Clauss)	1
18	No-Nic Stripper, Blue (Clauss)	1
19	Autocleaner (Netpec)	1
20	Jacket Stripper, T5 (Clauss)	1
21	Alcohol Dispenser, 4 Oz. (F.I.S.)	1
22	Ruler, 6" (Fibertron)	1
23	Diamond Polishing Film, 9 Microm, 6 x 6 (3M)	4
24	Diamond Polishing Film, 3 Microm, 6 x 6 (3M)	6
25	Diamond Polishing Film, 1 Microm, 6 x 6 (3M)	6
26	Resilient Rubber Pad (3M)	1
27	Glass Polishing Plate, 8" x 8" (Fibertron)	1
28	Cleaning Wire (F.I.S.)	1
29	Compressed Air (Fibertron)	1
30	Kim-Wipes (Kimberly-Clark)	1
31	Continuity Test, ST (F.I.S.)	1
32	Epoxy Applicator (Syringe) (Fibertron)	10
33	Mini Foam Swab, 2.5 mm (F.I.S.)	50
34	Tra-Bound Adhesive (Tra-Con)	10
35	LED Source W/D38999 Aprt, 1300nm Wvlngh (Rifocus)	1
36	Power Meter W/D38999 Aprt, 1300nm Wvlngh (Rifocus)	1
37	ST Adapter for Power meter (Rifocus)	1
38	Crimp Tool for 181-011 & 181-012 Termini (Kitco F.O.)	1
39	ST Adapter for LED Source (Rifocus)	1
40	Terminus Removal Tool, Front Release (Kitco)	1
41	Alignment Sleeve Removal Tool (Kitco)	1

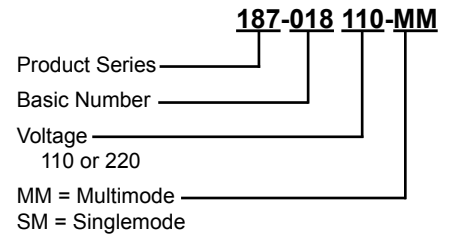

**FOR USE
WITH GLENAIR
Front Release
181-011 & 012
TERMINI**



Fast, Cost-Effective Shielding Termination

The BAND-IT® clamping system provides quick, easy, cost-effective and highly reliable termination of braided metallic shielding or fabric braid. Two sizes of banding tools and bands (bands are also available in standard and extended lengths) allow complete flexibility in terminating EMI shielding and protective mechanical braiding to fiber optic and electrical harnesses. Glenair's complete line of BAND-IT® products are in stock and ready for immediate shipment.



Manual Hand Tools

Hand Banding Tool 600-058

The 600-058 Hand Banding Tool weighs 1.18 lbs., and is designed for standard clamping bands 600-052 and 600-090 (see page 36) in a tension range from 100 to 180 lbs. Calibrate at 150 lbs. ± 5 lbs. for most shield terminations. Tool and band should never be lubricated.

Reference: BAND-IT® part number A40199.

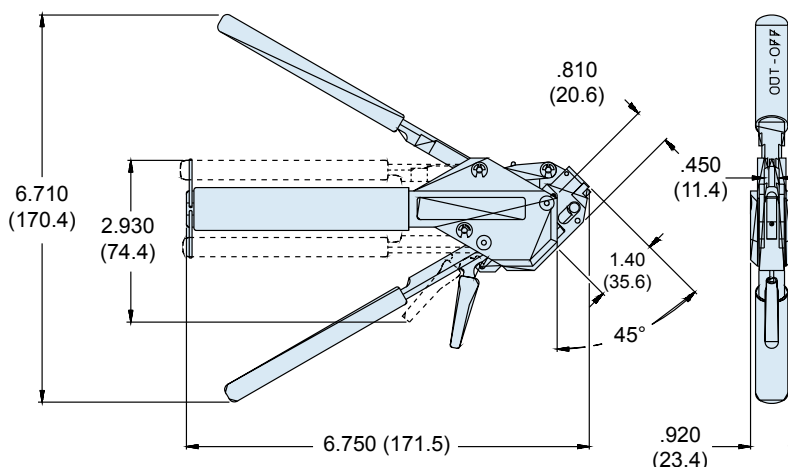

Hand Micro Banding Tool 600-061

The 600-061 Hand Micro Banding Tool weighs 1.18 lbs., and is designed for micro clamping bands 600-057 and 600-083 (see page 36) in a tension range from 50 to 85 lbs. Calibrate at 75lbs +2 lbs. -7 lbs. for most shield terminations. Tool and band should never be lubricated.

Reference: BAND-IT® part number A30199.

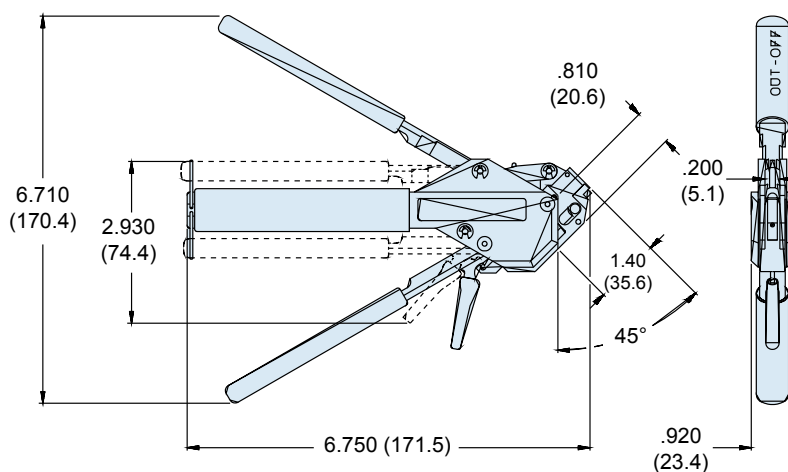

Metric Dimensions (mm) are indicated in parentheses.

Standard Band 600-052 and Precoiled Standard Band 600-052-1

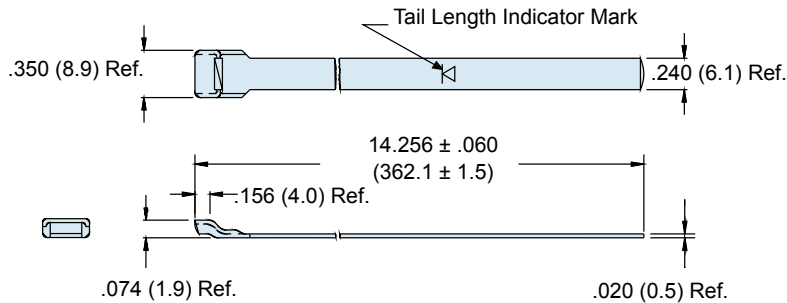

The 600-052 Standard Band is precision constructed of 300 Series SST/Passivate and designed for use with the 600-058 Hand Banding Tool or the 600-067 Pneumatic Banding Tool. Double-wrapped bands will accommodate diameters up to approximately 1.8 inches (45.7). Bands may be ordered flat (600-052) or precoiled (600-052-1). Bands come bagged and tagged in quantities from 1 to 100.

Reference: **BAND-IT®** Part Number **A10086**

Extended-Length Standard Band 600-090 and Precoiled Extended-Length Standard Band 600-090-1

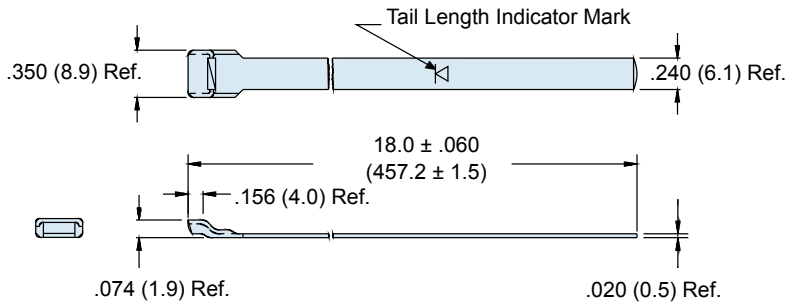

The 600-090 Extended Length Standard Band is precision constructed of 300 Series SST/Passivate, and designed for use with the 600-058 Hand Banding Tool or the 600-067 Pneumatic Banding Tool. Double-wrapped bands will accommodate diameters up to approximately 2.5 inches (63.5). Bands may be ordered flat (600-090), or precoiled (600-090-1). Bands come bagged and tagged in quantities from 1 to 100.

Reference: **BAND-IT®** Part Number **A11086**

Micro-Band 600-057 Precoiled Micro-Band 600-057-1

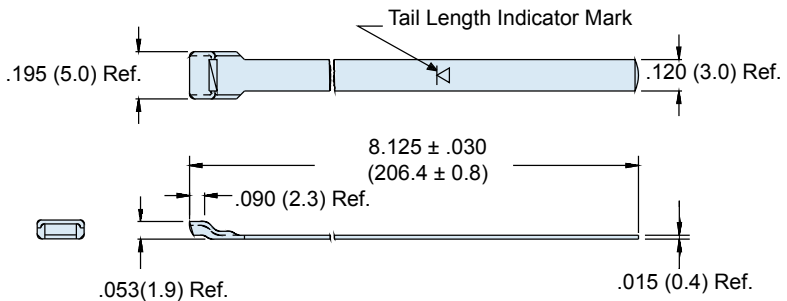

The 600-057 Micro Band is precision constructed of 300 Series SST/Passivate, and designed for use with the 600-061 Hand Banding Tool or the 600-068 Pneumatic Banding Tool. Double-wrapped bands will accommodate diameters up to approximately .88 inches (22.4). Bands may be ordered flat (600-057), or precoiled (600-057-1). Bands come bagged and tagged in quantities from 1 to 100.

Reference: **BAND-IT®** Part Number **A31186**

Extended Length Micro-Band 600-083 Precoiled Micro-Band 600-083-1

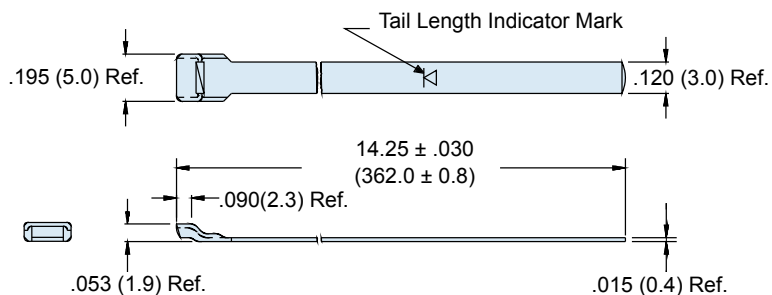

The 600-083 Extended Length Micro-Band is precision constructed of 300 Series SST/Passivate, and designed for use with the 600-061 Hand Banding Tool or the 600-068 Pneumatic Banding Tool. Double-wrapped bands will accommodate diameters up to approximately 1.88 inches (47.8). Bands may be ordered flat (600-083), or precoiled (600-083-1). Bands come bagged and tagged in quantities from 1 to 100.

Reference: **BAND-IT®** Part Number **A31089**.

Metric dimensions (mm) are indicated in parentheses. Consult factory for diameters above 2.5 inches (63.5).

The BAND-IT® Clamping System EMI Shield Termination Instructions

1. Prepare Cable Braid for termination process (Figure 1).
2. Push Braid forward over Adapter Retention Lip to the Adapter Incline Point (or .4" [10.2mm] minimum braid length). Milk Braid as required to remove slack and ensure a snug fit around the shield termination area (Figure 2).

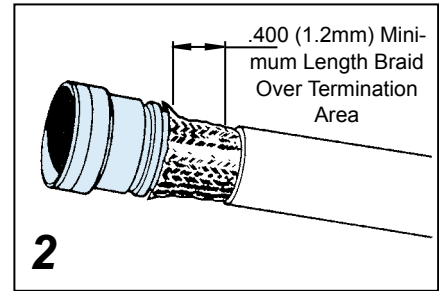
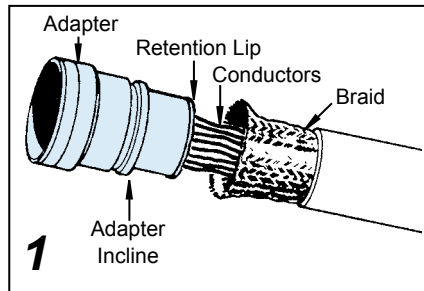

3. Prepare the Band in the following manner:

IMPORTANT: Due to Connector/Adapter circumference, it may be necessary to prepare the Band around the Cable or Retention Area.

- A. Roll Band through the Buckle Slot twice. (Bands must be double-coiled.)
- B. Pull on Band until Mark (▷|) is within approximately .250 inch (6.4mm) of Buckle Slot (Figure 3). The Band may be tightened further if desired.

NOTE: Prepared Band should have (▷|) Mark visible approximately where shown in Figure 3.

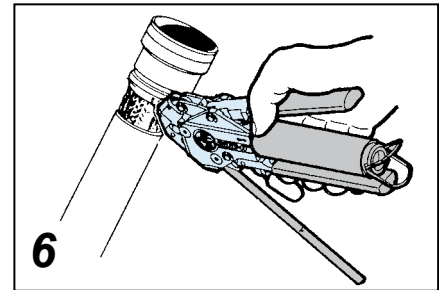
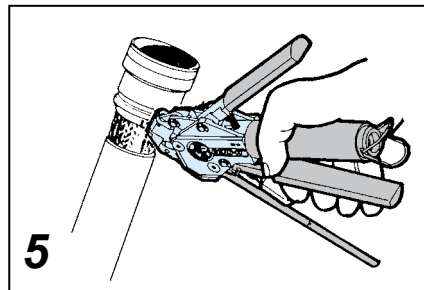
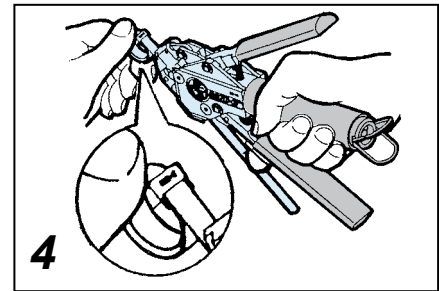
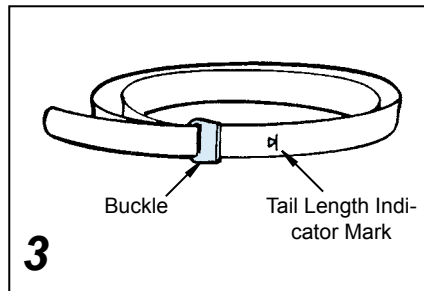

Shield Termination Clamping Process (Figures 4 thru 8)

NOTE: To free Tool Handles, move Holding Clips to center of Tool.

4. Squeeze Gripper Release Lever and insert Band into the front end opening of the Tool. (NOTE: Circular portion of looped band must always face downward.)
5. Aligning the Band and Tool with the Shield Termination Area, squeeze Black Pull-Up Handle repeatedly using short strokes until it locks against Tool Body. (This indicates the Band is compressed to the Tool Precalibrated Tension.)

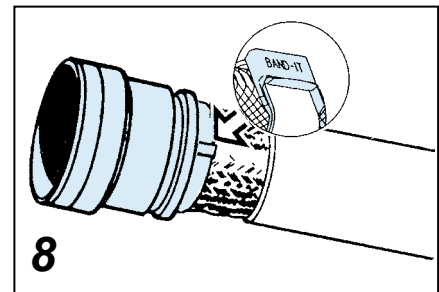
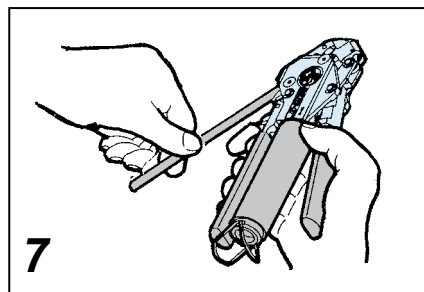

NOTE: If alignment of band and shield is unsatisfactory, tension on band can be relaxed by pushing on slotted release lever on top of tool. Make adjustments as necessary and again squeeze black pull-up handle.

6. Complete the Clamping Process by squeezing the Gray Cut-Off Handle.
7. Remove excess band from tool and dispose.
8. Inspect Shield Termination.

182-001
Fiber Optic Polishing Tool for
181-001 and 181-002 Termini

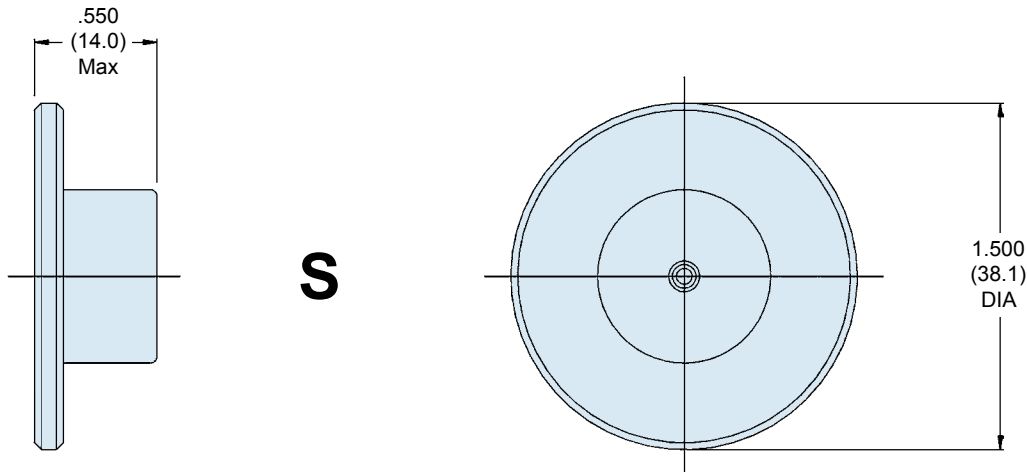
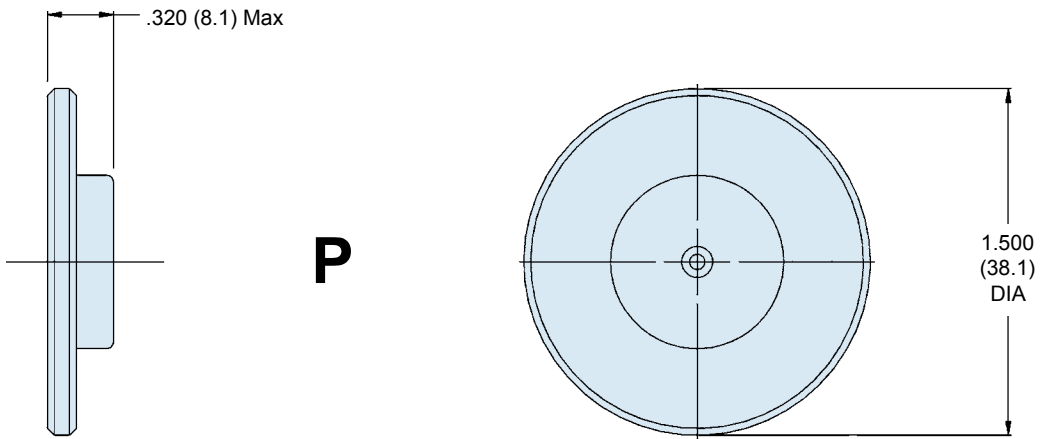
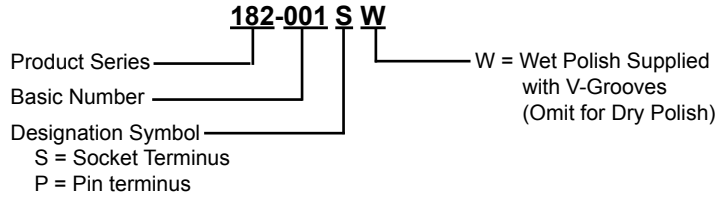

APPLICATION NOTES

1. Assembly packaged in plastic bag and tag identified with manufacturer's name and part number.
2. Assembly marked with "PIN" or "SKT" and part number.
3. Material/Finish: Stainless Steel/Passivated.
4. Metric Dimensions (mm) are indicated in parentheses.

182-002 W

Product Series ————|
Basic Number ————|
W = Wet Polish Supplied ————|
with V-Grooves
(Omit for Dry Polish)

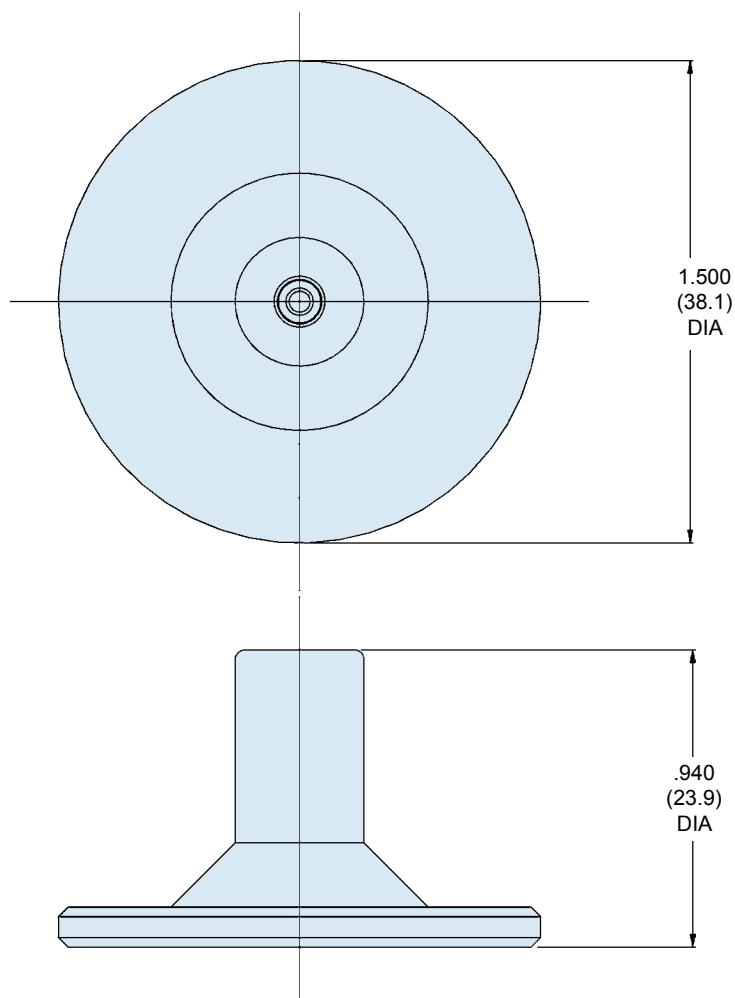

APPLICATION NOTES

1. Assembly packaged in plastic bag and tag identified with manufacturer's name and part number.
2. Assembly marked with "TEST PROBE" and part number.
3. Material/Finish: Stainless Steel/Passivated.
4. Metric Dimensions (mm) are indicated in parentheses.

182-005
Fiber Optic Polishing Tool
 for 181-011 and 181-012 Front Release Termini



182-005 S W

Product Series ———
 Basic Number ———
 Designation Symbol ———

S = Socket Terminus
 P = Pin terminus

W = Wet Polish Supplied
 with V-Grooves
 (Omit for Dry Polish)

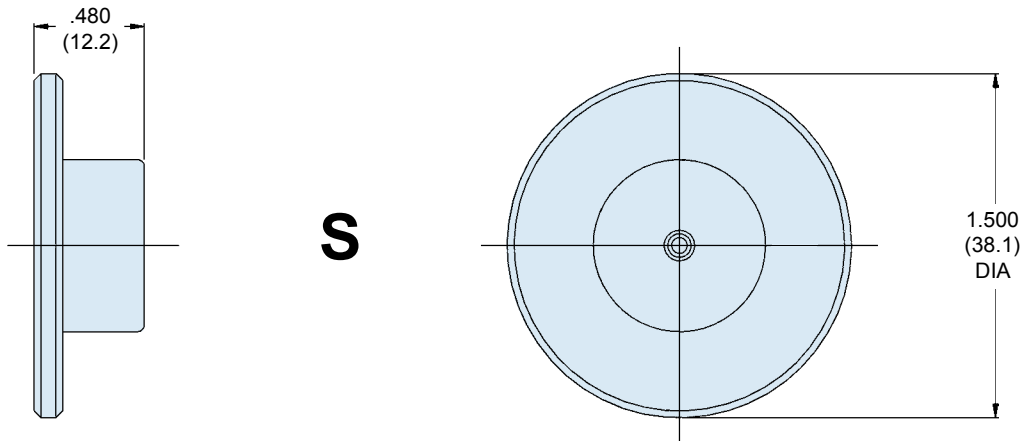
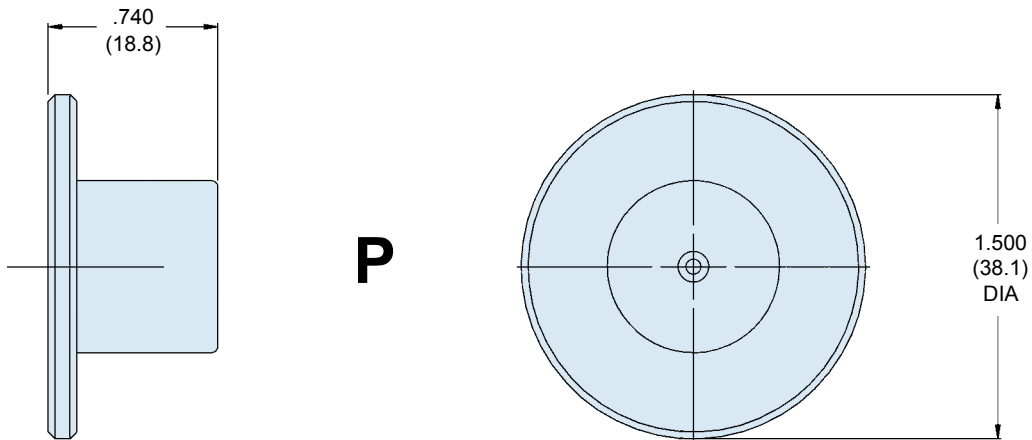

APPLICATION NOTES

1. Assembly packaged in plastic bag and tag identified with manufacturer's name and part number.
2. Assembly marked with "PIN" or "SKT" and part number.
3. Material/Finish: Stainless Steel/Passivated.
4. Metric Dimensions (mm) are indicated in parentheses.

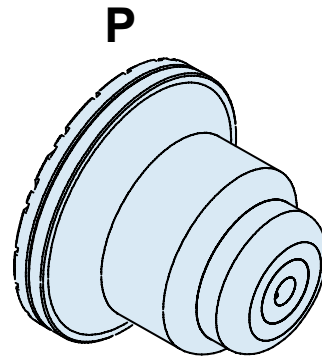
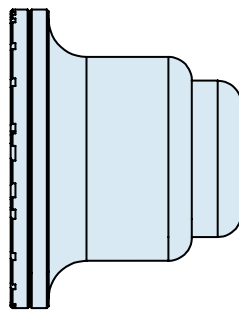
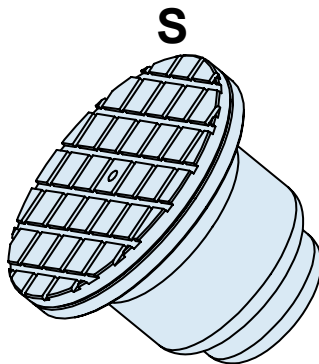
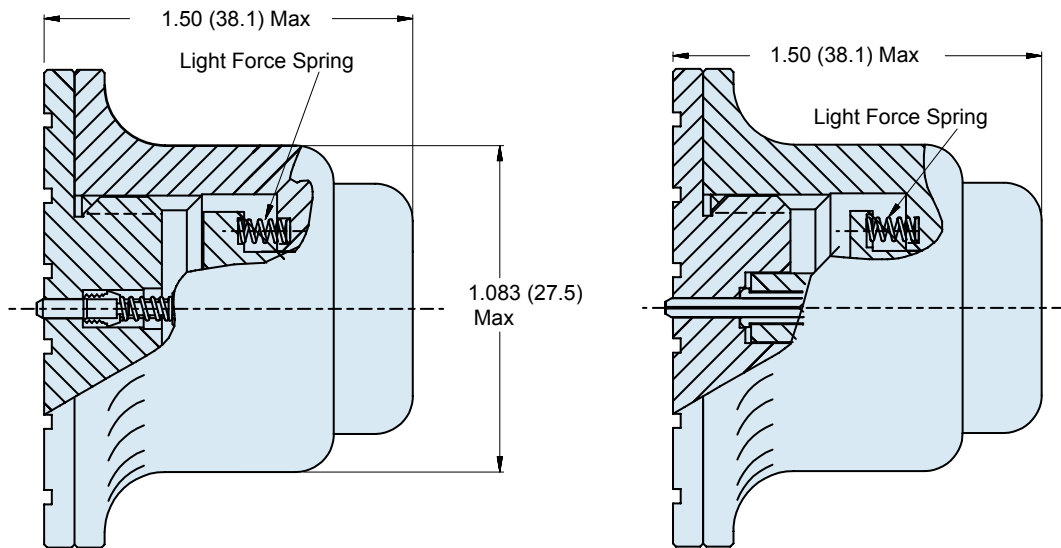
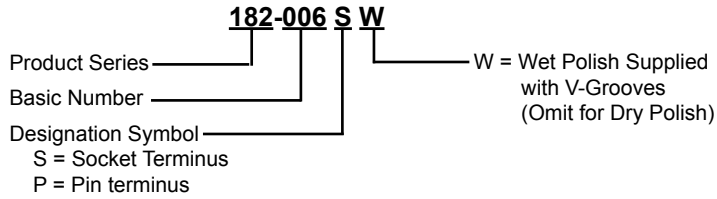

APPLICATION NOTES

1. Termini and springs to be shipped loose. Consult factory for details.
2. Material/ Finish: Stainless Steel/ Passivate.
3. Assembly packaged in plastic bag and tag identified with manufacture's name and part number.
4. Metric dimensions (mm) are indicated in parentheses.

182-007
Fiber Optic Termini Polishing Tool
 for 181-045 2.5 mm Termini



182-007 W
 Product Series ———
 Basic Number ———
 W = Wet Polish Supplied
 with V-Grooves
 (Omit for Dry Polish)

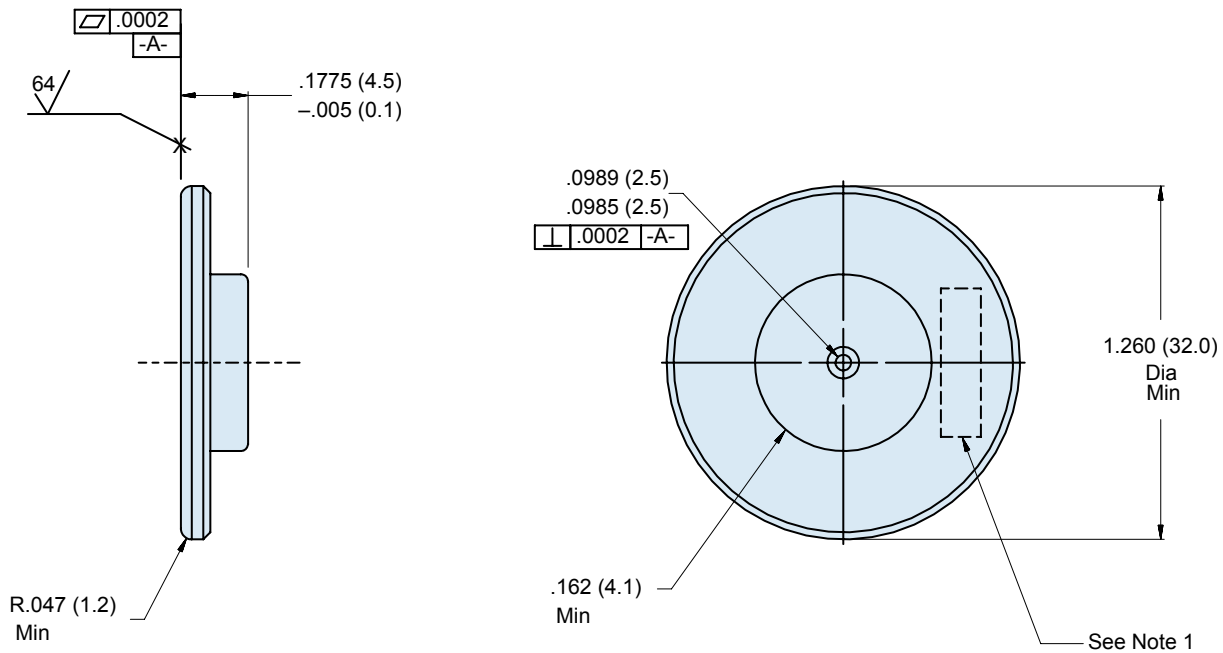

APPLICATION NOTES

1. Assembly marked with part number, 06324 and date code.
2. Material/ Finish: Stainless Steel/Pasivated
3. Metric dimensions (mm) are in parentheses.



Glenair Fiber Optic Termini Cleaning Procedure

Glenair has developed exactly dimensioned cleaning swabs for cleaning difficult-to-clean, recessed socket termini.

Each swab's foam tip is the perfect size to clean both the alignment sleeve and the glass core area of the fiber.

Please follow these instructions when cleaning fiber optic termini:

Glenair Recommends the Following Procedure for Cleaning Glenair Fiber Optic Termini:

1. Remove loose contamination with a dry swab.
2. Blow pressurized, filtered air (or instrument grade canned air) onto terminus end face.
3. Inspect end face using 10X magnification minimum.
4. If contamination is still present, take the following measures:
 - A. Soak swab foam tip with 99%+ pure alcohol.
 - B. Wipe the wet swab across the terminus end face.
 - C. Wipe a dry swab across the terminus end face immediately to guard against potential air-dried alcohol film residue.

187-021
Fiber Optic Cleaning Swab
1.25 mm Cletop

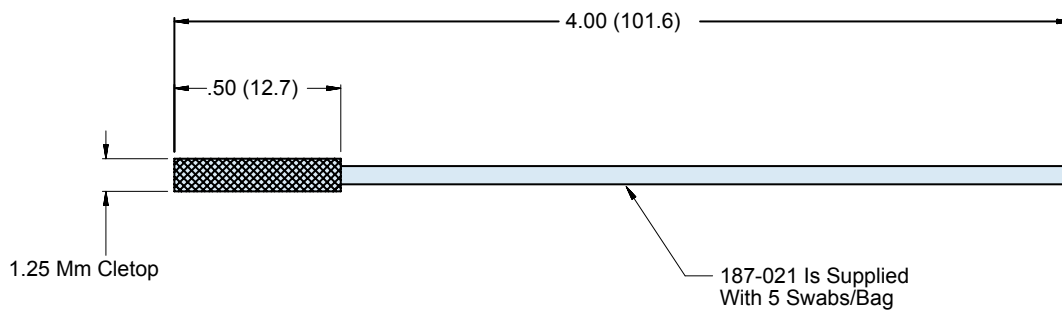
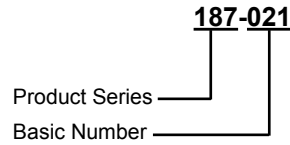

APPLICATION NOTES

1. Bag & tag with manufacturer's name and P/N, space permitting.
2. Metric dimensions (mm) are indicated in parentheses.



187-024
Fiber Optic Cleaning Swab
for Part 181-001 Socket Terminus

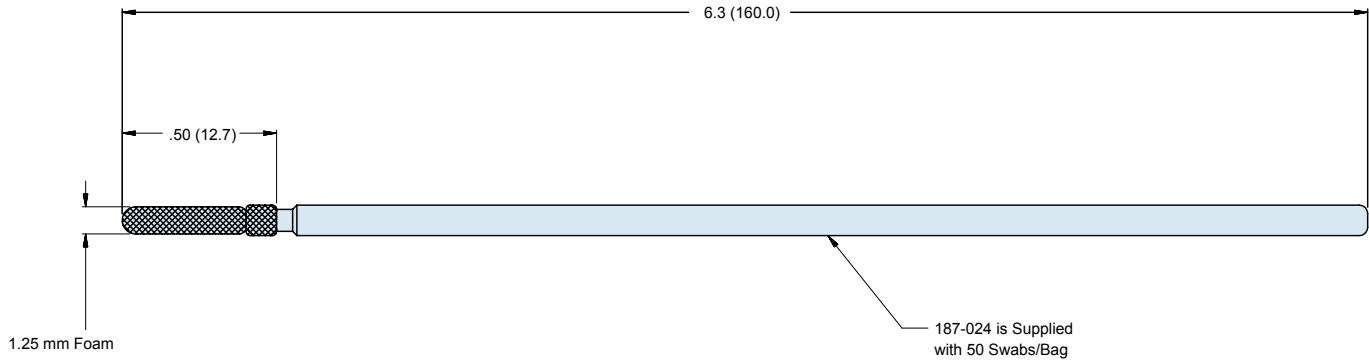
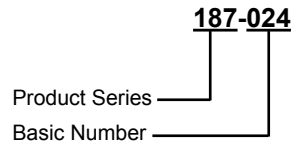

APPLICATION NOTES

1. Bag & tag with manufacturer's name and P/N, space permitting.
2. Metric dimensions (mm) are indicated in parentheses.

187-045
Fiber Optic Cleaning Swab
2.00 mm and 2.50 mm Cletop



187-045

Product Series

Basic Number

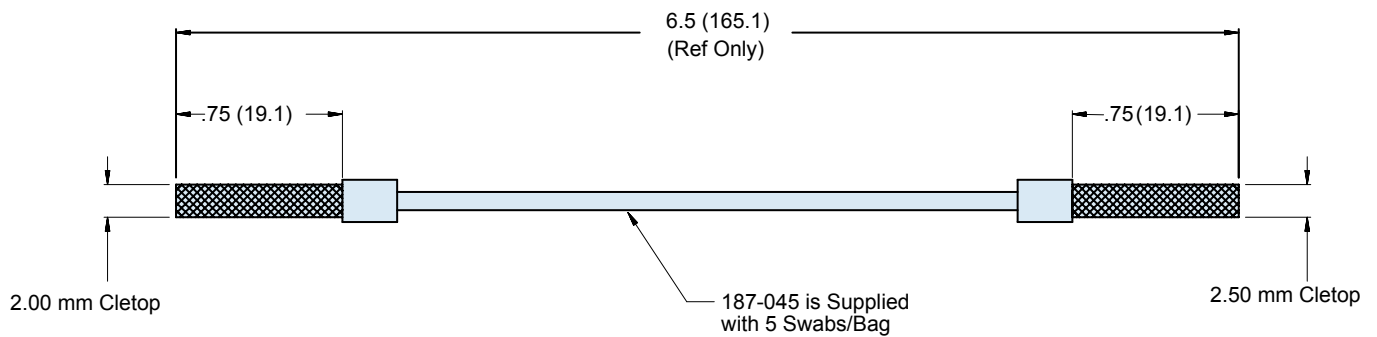

APPLICATION NOTES

1. Bag & tag with manufacturer's name and P/N, space permitting.
2. Metric dimensions (mm) are indicated in parentheses.

REVERSE THE PRESS!!!

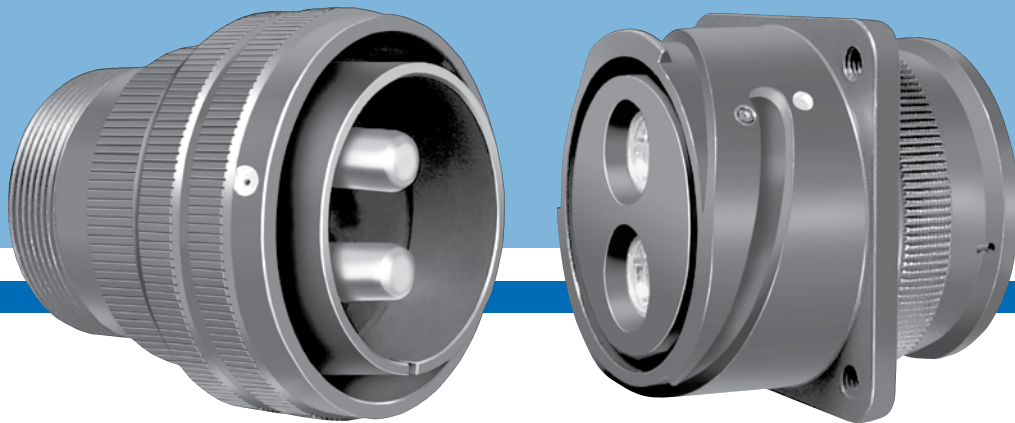

Committal S.p.A
Is Now a Division of Glenair
Same Great Products
Worldwide Service and Support



1211 Air Way
Glendale, California 91201-2497
Telephone: 818-247-6000 · Facsimile: 818-500-9912 · EMail: sales@glenair.com
United States · United Kingdom · Germany · Nordic · France · Italy · Spain · Japan
www.glenair.com

A World of Interconnect Solutions

The world's broadest selection of interconnect hardware—in stock and ready for immediate same-day shipment

Glenair's World of Interconnect Solutions Capability Brochure

A color overview of Glenair's unique range of interconnect products and services. Available in English, French, German and Japanese.

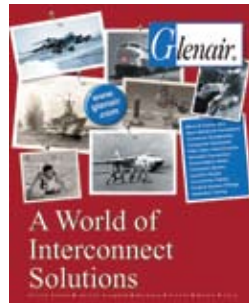

Circular Connector Backshells/Accessories

The most sought-after catalog in the interconnect industry, this thick book contains literally hundreds of pages of drawings, tables and detailed information about the world's largest and most complete selection of connector accessories.

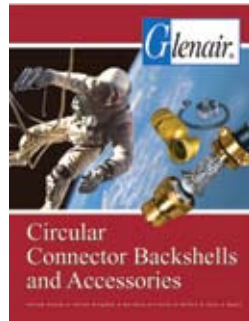

Convoluted Tubing, Braiding, and Flexible Metal-Core Conduit Systems

A 128-page catalog showing Glenair's line of plastic & metal-core conduit; loaded with fittings, sleeving, jacketing, and complete factory assembly services.



Rectangular Backshells and Accessories

A comprehensive catalog of Glenair rectangular rack and panel style backshells and accessories. Includes MIL-C-24308, MIL-C-83733, MIL-C-81659, MIL-DTL-83513, MIL-C-83527, ARINC, Cannon and Hypertronics.



Order Glenair's Interconnect Product Guide CD for detailed information about our complete line of products.



Everything you need to know about Glenair is on this disc, which includes catalogs, brochures, white papers data sheets and more. Pop this CD into your computer and breeze through the world's broadest selection of interconnect products, solutions and services.

Composite Thermoplastic Connectors, Backshells, and Enclosures

Glenair is the world's leading supplier of composite solutions. Glenair has made an across-the-board commitment to integrate composites into every facet of the electrical interconnect system.



Shipboard Interconnect Hardware

Glenair's unique line of shipboard interconnect products includes MIL-C-24758 conduit systems, cable shield grounding assemblies, feed-through fittings, Sigmaform backshells and more.



Connector and Backshell Buyer's Guide

A complete introduction to backshells and connector hardware, featuring Glenair's enormous 35,000 part number Same-Day inventory—the largest and most complete in the world.

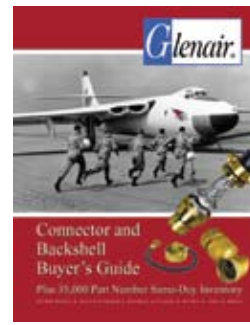

A World of Interconnect Solutions

- Fast Turnaround on Quotes and Custom Orders
- 50,000 Part Number Same-Day Inventory
- No "Minimum Order" Policy
- Abundant Manufacturing Capacity
- Full Spectrum Product Lines

M83513 Micro-D TwistPin Connectors

M32139 Nanominiature Connectors

M85049 Circular Connector Accessories

Composite Connectors and Backshells

Connector Covers, Caps and Boots

D-Subminiature and Micro-D Backshells

D38999 Fiber Optic Connectors and Termini

M28876 Fiber Optic Connectors and Termini

MIL-DTL-38999 Hermetic Connectors

MIL-C-28840 Shipboard Connectors

Series 80 "Mighty Mouse" Connectors

Sav-Con® Connector Savers

Series 22 Geo-Marine® Connectors

M24758 Shipboard Conduit and Fittings

Metal-Core and Plastic Convoluted Tubing

D38999 EMI/EMP Filter Connectors

5015 / VG95234 Reverse Bayonet Connectors

Overmolded and Braided Cable Assemblies

EMI Braided Sleeving and Banding Tools

EMI Junction Boxes and Box Assemblies

Connector Backshell Assembly Tools

Mil-Spec Nut Rings and EMI/RFI Gaskets

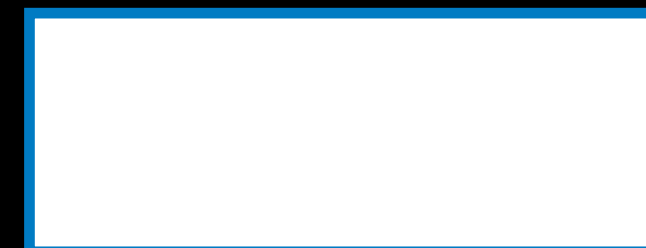

Glenair, Inc.
Worldwide Headquarters
 1211 Air Way
 Glendale, California
 United States of America
 91201-2497

Telephone:
 818-247-6000
 Facsimile:
 818-500-9912
 sales@glenair.com

Glenair, Inc.
Committal Product Sales and Support Group (US)
 25 Village Lane
 Wallingford, CT 06492

Telephone:
 203-741-1115
 Facsimile:
 203-741-0053
 sales@glenair.com

Glenair UK Ltd
 40 Lower Oakham Way
 Oakham Business Park
 P.O. Box 37, Mansfield
 Notts, NG18 5BY
 England

Telephone:
 44-1623-638100
 Facsimile:
 44-1623-638111
 sales@glenair.co.uk

Glenair Electric GmbH
 Siemensstrasse 9
 D-61449 Steinbach
 Germany

Telephone:
 49-6171-5905-0
 Facsimile:
 49-6171-5905-90
 germany@glenair.com

Glenair B. V.
 Beneluxweg 37
 4904 SJ Oosterhout
 Netherlands

Telephone:
 31-162-47-24-90
 Facsimile:
 31-162-47-24-91
 sales@glenair.nl

Glenair France SARL
 Paris Nord 2
 181 Avenue des Nations
 BP 60056 Villepinte
 95972 Roissy Charles De Gaulle Cedex
 France

Telephone:
 33-1-49-89-66-33
 Facsimile:
 33-1-49-89-66-30
 sales@glenair.fr

Glenair Connectors Italia S.R.L.
and Committal Product Sales and Support Group (EU)
 Via Santi, 1-20037
 Paderno Dugnano
 Milano, Italy

Telephone:
 +39-02-91082121
 Facsimile:
 +39-02-99043565
 sales-italia@glenair.com

Glenair Nordic AB
 Gustav III : S Boulevard 46
 S - 16973 Solna
 Sweden

Telephone:
 46-8-50550000
 Facsimile:
 46-8-50550001
 sales@glenair.se

Glenair Spain
 C/ La Vega, 16
 45612 Velada
 Spain

Telephone:
 34-925 89 29 88
 Facsimile:
 34-925 89 29 87
 sales@glenair.es

Visit us at www.glenair.com and use the literature order form for immediate catalog fulfillment

Index of Fiber Optic Products and Part Numbers



Fiber Optic Interconnect Technologies & Packaging...Section A

Product Selection Guide.....	A-1
Fiber Optic Operation.....	A-4
Cable Construction.....	A-5
Military Standards.....	A-6
Connectors and Termini and Fiber Optic Terminology.....	A-7
Fiber Optic Backshells.....	A-8
Costs and Benefits.....	A-9
Packaging Options.....	A-10
Expanded Beam Fiber Optic Connectors and Cables.....	A-14
Application Check List for Converting to Fiber Optics.....	A-18

MIL-DTL-38999 Fiber Optic Connection System.....B-1

181-001 Size 16 Fiber Optic Socket Terminus, MIL-PRF-29504/5.....	B-2
181-002 Size 16 Fiber Optic Pin Terminus, MIL-PRF-29504/4.....	B-4
181-046 Fiber Optic Dummy Pin Terminus, MIL-PRF-29504/4 & /5 Style.....	B-6
MIL-PRF-29504 Termini Performance Data.....	B-7
181-001 and 181-002 Termini Abbreviated Termination Procedure.....	B-8
180-091 MIL-DTL-38999 Style Fiber Optic Connector Insert Arrangements and Finish Table II.....	B-10
180-091 MIL-DTL-38999 Style Fiber Optic Connector Panel Cut-Out and Panel Mounting Holes for Wall Mount Receptacles.....	B-11
180-091 (05 In-Line) Advanced Fiber Optic Receptacle Connector MIL-DTL-38999 Series III Style.....	B-12
180-091 (06 Plug) Advanced Fiber Optic Plug Connector MIL-DTL-38999 Series III Style.....	B-14
180-091 (08 Jam Nut Mount) Advanced Fiber Optic Receptacle Connector MIL-DTL-38999 Series III Style.....	B-16
180-091 (H7 Square Flange Wall Mount) Advanced Fiber Optic Receptacle Connector MIL-DTL-38999 Series III Style with Standard Hole.....	B-18
180-091 (S7 Square Flange Wall Mount) Advanced Fiber Optic Receptacle Connector MIL-DTL-38999 Series III Style with Slotted Holes.....	B-20
180-091 (T7 Square Flange Wall Mount) Advanced Fiber Optic Receptacle Connector MIL-DTL-38999 Series III Style with Tapped Holes.....	B-22
180-052 2 Channel Receptacle Connector for MIL-PRF-29504/5 Socket Terminus.....	B-24
180-053 2 Channel Plug Connector for MIL-PRF-29504/4 Pin Terminus.....	B-25
180-076 Fiber Optic Splice for MIL-PRF-29504/4 & 5 Termini.....	B-26
Glenair ASAP Fiber Optic Cable Sets, Rugged Overmolded Assembly D38999 Series III to D38999 Series III.....	B-28
Glenair ASAP Fiber Optic Cable Sets, Plastic and Metal-Core Conduit Assembly D38999 Series III to D38999 Series III.....	B-30
Glenair ASAP Fiber Optic Cable Sets, Field Repairable Banding Backshell Assembly D38999 Series III to D38999 Series III.....	B-32
Glenair ASAP Fiber Optic Cable Sets, Inside-the-Box Receptacle/Pigtail Assembly D38999 Series III to St, FC, SC, LC & SMA.....	B-34
Glenair ASAP Fiber Optic Cable Sets, Inside-the-Box Receptacle/Pigtail Assembly with FiberCon® Backshell, D38999 Series III to St, FC, SC, LC & SMA.....	B-36
Glenair ASAP Fiber Optic Cable Sets, Inside-the-Box Receptacle/Pigtail Assembly with Low Profile Backshell and Conduit, D38999 Series III to St, FC, SC, LC & SMA.....	B-38

GHD • Glenair High Density Fiber Optic Connection System....C-1

181-041 18 AWG Front Release High Density Fiber Optic Pin Terminus.....	C-2
181-047 18 AWG Front Release High Density Fiber Optic Keyed Pin Terminus.....	C-4
180-122 Glenair High Density Fiber Optic Connection System Insert Arrangements, Materials and Finishes.....	C-6
180-122 Glenair High Density Fiber Optic Connection System Panel Cut-Out and Mounting Holes.....	C-7
180-122 (05) 18 AWG High Density Front Release MIL-DTL-38999 Style Fiber Optic In-Line Receptacle Connector.....	C-8
180-122 (06) 18 AWG High Density Front Release MIL-DTL-38999 Style Fiber Optic Plug Connector with Alignment Sleeve Retainer.....	C-10

180-122 (H7) 18 AWG High Density Front Release MIL-DTL-38999 Style Fiber Optic Receptacle Connector Square Flange Wall-Mount with Round Holes.....	C-12
180-122 (S7) 18 AWG High Density Front Release MIL-DTL-38999 Style Fiber Optic Receptacle Connector Square Flange Wall-Mount with Slotted Holes.....	C-14
180-122 (08) 18 AWG High Density Front Release MIL-DTL-38999 Style Fiber Optic Jam-Nut Mount Receptacle Connector.....	C-16

MIL-PRF-28876 Style Fiber Optic Connection System.....D-1

181-040 MIL-PRF-29504/15 Front Release Socket Terminus.....	D-2
181-039 MIL-PRF-29504/14 Front Release Pin Terminus.....	D-3
180-051 M29504/03 Style Dummy Terminus.....	D-9
MIL-PRF-28876 Style Fiber Optic Connection System Ordering Information.....	D-4
180-040 (-03, -13, -23, -33) MIL-PRF-28876 Style Fiber Optic Wall Mount Receptacle Connector.....	D-6
180-040 (-06, -16, -26, -36) MIL-PRF-28876 Style Fiber Optic Plug Connector.....	D-7
180-040 (-04, -14, -24, -34) MIL-PRF-28876 Style F/O Jam Nut Receptacle.....	D-8

Next Generation Fiber Optic Connection System.....E-1

181-043 Rear Release Genderless Terminus for Next Generation (NGCON) Fiber Optic Connectors.....	E-2
180-118 (02 Wall-Mounting) Next Generation (NGCON) Fiber Optic Receptacle Connector.....	E-3
180-118 (06 Plug Assembly) Next Generation (NGCON) Fiber Optic Plug Connector.....	E-4

Glenair GFOCA Fiber Optic Connection System.....F-1

181-050 GFOCA Style Genderless Terminus for M29504/16/17 Hermaphroditic 4-Channel Connectors.....	F-3
180-116 GFOCA M83526/16 Style Fiber Optic Plug Connector Hermaphroditic 4-Channel with Dust Cover.....	F-4
180-117 GFOCA M83526/17 Style Fiber Optic Jam Nut Receptacle Connector Hermaphroditic 4-Channel with Dust Cover.....	F-6

Glenair Front Release Fiber Optic Connection System.....H-1

181-011 Fiber Optic Socket Terminus, Size 16 Front Release with Protective Cover Alignment Sleeve.....	H-2
181-012 Fiber Optic Pin Terminus, Size 16 Front Release.....	H-4
180-063 Micro-D Fiber Optic Receptacle Connector for Glenair Front Release Pin Terminus 181-011.....	H-6
180-064 Micro-D Fiber Optic Plug Connector for Glenair Front Release Socket Terminus 181-011.....	H-7
180-065 D-Subminiature Fiber Optic Pin Receptacle Connector for Glenair Front Release Pin Terminus 181-012.....	H-8
180-066 D-Subminiature Fiber Optic Plug Connector for Glenair Front Release Pin Terminus 181-011.....	H-10

180-070 (-6 and -7) Fiber Optic Plug/Receptacle Special Environmental Composite Connector for Glenair 181-011 and 181-012 Front Release Pin Termini.....	H-12
180-071 (-3) Wall-Mount Single Channel Environment Resistant Fiber Optic Receptacle Connector.....	H-14
180-071 (-4) Jam Nut Single Channel Environment Resistant Fiber Optic Receptacle Connector.....	H-16
180-071 (-6) Single Channel Environment Resistant Fiber Optic Plug Connector.....	H-18

Fiber Optic Backshells and Accessories.....I-1

189-016 Environment Resistant Backshell with Banding Strain Relief for MIL-DTL-38999 Series III Fiber Optic Connectors.....	I-2
189-037 Environment Resistant Backshell with Banding Strain Relief for MIL-DTL-38999 Series III Fiber Optic Connectors.....	I-4
337-014 Composite Thermoplastic Backshell for MIL-DTL-38999 Series III & IV Fiber Optic Connectors.....	I-6
377-040 Composite MIL-DTL-38999 Series III Fiber Optic Strain-Relief Backshell.....	I-8
377-041 Composite MIL-DTL-38999 Series III FiberCon Conduit Adapter.....	I-9
189-015 Environmental Banding Backshell for Multichannel M85045 Shipboard Fiber Optic Cable for use with MIL-C-28876 or Glenair 180-040 Connectors.....	I-10
189-001 Fiber Optic Backshell with Split Clamp MIL-PRF-28876 Environmental.....	I-12
189-007 Fiber-Con Backshell for MIL-PRF-28876 Connectors.....	I-14
189-009 Banding Backshell / Molding Adapter for MIL-PRF-28876 Connectors.....	I-16
189-055 Special Environment Resistant Backshell with Direct Coupling for 180-071 Single Channel Fiber Optic Connector.....	I-18
630-015 Fiber Optic Cable Bulkhead Adapter with Kevlar Braid Sock.....	I-20
630-015 Glenair Assembly Procedure GAP-017A for Fiber Optic Feedthrough Adapter when using Conventional Fiber Optic Cable.....	I-20
660-023 and 660-024 MIL-DTL-38999 Series III Metal Protective Covers.....	I-26
660-047 and 660-048 Composite MIL-PRF-28840 Protective Covers.....	I-28
660-049 and 660-050 Composite MIL-DTL-38999 Protective Covers.....	I-29
660-072 and 660-073 MIL-PRF-28876 Style Threaded Protective Covers.....	I-30
189-047 (3) Wall-Mounting/Jam Nut Receptacle Protective Cover for Single Channel 180-071 Fiber Optic Connector.....	I-32
189-047 (6) Plug Protective Cover for Single Channel 180-071 Fiber Optic Connector.....	I-34
187-019 and 187-029 Vinyl Dust Caps.....	I-36

Conduit Systems, Fittings, Transitions & Adapters....J-1

120-100 Series 74 Helical Convuluted Tubing (MIL-T-81914) Natural or Black PFA, FEP, PTFE, Tefzel® (ETFE) or PEEK, Type A Tubing Only, No Braid.....	J-2
120-103 Series 74 Helical Convuluted Tubing (MIL-T-81914) Natural or Black PFA, FEP, PTFE, Tefzel® (ETFE) or PEEK, Type B with External Black Dacron® Braid.....	J-3
182-014 Backshell for PEEK Convuluted Tubing to be used with MIL-C-28876 Fiber Optic Connectors.....	J-4
189-038 Composite Connector Backshell Adapter for Helical Convuluted Tubing to be used with MIL-DTL-38999 Series III & IV Fiber Optic Connectors.....	J-6
189-039 Straight, 45° and 45° Composite Connector Backshell Adapter for MIL-PRF-28876 Fiber Optic Connectors.....	J-8
712-416 PEEK Only Composite Straight Backshell Adapter for MIL-DTL-38999 Series III & IV Fiber Optic Connectors.....	J-10

189 M* 052 Convuluted Tubing Backshell for Series 80 "Mighty Mouse" Fiber Optic Connectors.....	J-12
---	------

Fiber Optic Extruded Bulk Cable.....K-1

ABC 3571 Bulk Simplex Fiber Optic Cable, 100/140 Graded Index.....	K-2
ABC 3580 Bulk Simplex Fiber Optic Cable, 50/125 Graded Index.....	K-3
ABC 3586 Bulk Simplex Fiber Optic Cable, 9.3/125 Singlemode Stepped Index.....	K-4
ABC 3569 Bulk Simplex Fiber Optic Cable, 62.5/125 Graded Index.....	K-5
ABC 3821 Bulk Simplex Fiber Optic Cable, 62.5/125 Simplex Cable.....	K-6

D38999 Fiber Optic Test Probes and Adapters.....L-1

User Instructions: Glenair MIL-DTL-38999 Fiber Optic Test Probes and Connector Adapters.....	L-2
ABC 54705 Fiber Optic Test Probe Simplex Cable Assembly.....	L-4
180-043 Feedthrough Probe Connector for MIL-DTL-38999 Series III Test Probe.....	L-5
180-049 Feedthrough Probe Connector to M29504/4 Pin Terminus.....	L-6
180-050 Feedthrough Probe Connector to M29504/5 Socket Terminus.....	L-7
180-044 (06 Plug) Fiber Optic Test Adapter for MIL-DTL-38999 Series III.....	L-8
180-044 (07 Receptacle) Fiber Optic Test Adapter for MIL-DTL-38999 Series III.....	L-10
180-072 (06 Plug) Fiber Optic Test Adapter for MIL-DTL-38999 Series I.....	L-12
180-072 (07 Receptacle) Fiber Optic Test Adapter for MIL-DTL-38999 Series I.....	L-14
180-073 (06 Plug) Fiber Optic Test Adapter with Special Insert Arrangement, MIL-DTL-38999 Series III.....	L-16
180-073 (07 Receptacle) Fiber Optic Test Adapter with Special Insert Arrangement, MIL-DTL-38999 Series III.....	L-18
180-089 (06 Plug) Fiber Optic Test Adapter MIL-PRF-28876.....	L-20
180-089 (07 Receptacle) Fiber Optic Test Adapter MIL-PRF-28876.....	L-22
180-102 (06 Plug) Fiber Optic Probe Adapter.....	L-24
180-102 (07 Receptacle) Fiber Optic Probe Adapter.....	L-25
FO1006 Glenair Fiber Optic Patch Cord.....	L-26
FO1007 Glenair Duplex Fiber Optic Patch Cord.....	L-27

Fiber Optic Termination and Assembly Tool Kits....M-1

187-017 Glenair Fiber Optic Termination Kit for MIL-PRF-29504/4 & /5 Termini (181-001 & 002).....	M-2
GBS1000 and GBS1001 Portable Fiber Optic Video Bore Scope Inspection System.....	M-4
GCB1000, GCB2000, and GCB3000 Fiber Optic CleanBlast® Cleaning System.....	M-6
GTK1000 Fiber Optic Testing Kit for Front Release 181-011 and -012 Termini.....	M-8
187-018 Glenair Fiber Optic Termination Kit for Front Release 181-011 & -012 Termini.....	M-9
600-058 and 600-061 Band-It® Clamping System Hand Banding Tools.....	M-10
600-052, 600-057, 600-090, and 600-083 Band-It® Clamping System Clamping Bands.....	M-11
Band-It® Clamping System EMI Shield Termination Instructions.....	M-12
182-001 Fiber Optic Polishing Tool for 181-001 and 181-002 Termini.....	M-13
182-002 Fiber Optic Polishing Tool for 181-006 Test Probe.....	M-14
182-005 Fiber Optic Polishing Tool for 181-011 and 181-012 Front Release Termini.....	M-15
182-006 Fiber Optic Socket Polishing Tool.....	M-16
182-007 Fiber Optic Termini Polishing Tool for 181-045 2.5 mm Termini.....	M-17
Glenair Fiber Optic Termini Cleaning Procedure.....	M-18
187-021 1.25 mm Cleotop Fiber Optic Cleaning Swab.....	M-19
187-024 Fiber Optic Cleaning Swab for Part 181-001 Socket Terminus.....	M-20
187-045 2.00 mm and 2.50 mm Cleotop Fiber Optic Cleaning Swab.....	M-21

Glenair®



Fiber Optic Interconnect Solutions



Tactical Fiber Optic Connectors, Cables and Termini

United States ■ United Kingdom ■ Germany ■ France ■ Nordic ■ Italy ■ Spain ■ Japan

Four Reasons to Add Glenair to Your Short List of Suppliers:

First and foremost you need availability.

Are the products and components you need either in stock or able to be manufactured in a short period of time? Glenair has built its reputation on fast turnaround. We maintain the world's largest inventory of connector accessories and deliver faster turnaround on quotes and orders than anyone else in our business. Today, Glenair is changing the way the interconnect industry operates: from a long lead-time, custom order problem; to a fast response, in-stock solution. From connector accessories to fiber optic termini, Glenair is the "same-day" leader.

Second, you need capacity.

Can the supplier respond to your evolving requirements with the factory capacity and labor necessary to meet every demand—from one piece to one hundred thousand? Glenair has built the largest capacity, broadest capability factory in the interconnect accessory industry. We have the knowledge, experience and equipment necessary to handle any production requirement, no matter how large or complex, and the manpower to tackle even the most aggressive production schedules.

Third, you need convenience in ordering.

Do your current suppliers insist on quantity or dollar minimums whenever you place an order? Are their products available only from distributors with limited product knowledge and equally limited shelf stock? Is it hard to get samples when and where you need them? Do you get charged expediting fees for accelerated production? If your answer to any of these questions is yes, we encourage you to consider Glenair, where complete convenience in ordering has been a guiding principle since 1956.

Finally, you need top quality products backed by outstanding technical support.

At Glenair, we've made product quality and worldwide technical support a major part of our approach to earning your trust and loyalty. We've established an unsurpassed sales, support and engineering presence in every major market in the world. And we've designed quality into every product we ship, by applying the experience and expertise gained from over 40 years in the business.

In every respect, our formula for serving the fiber optic interconnect customer is identical to the "best-value" service model we've relied on to maintain our leadership position in our core, connector accessory business:

- ***Same-Day Delivery on Our Most Popular Part Numbers***
- ***Lightning-Fast Turnaround on Quotes for Price and Delivery***
- ***No Price or Quantity Minimums***
- ***Outstanding Application Engineering and Worldwide Technical Support***